

EMCO CAMConcept T

Software description - software version 2.0 or higher

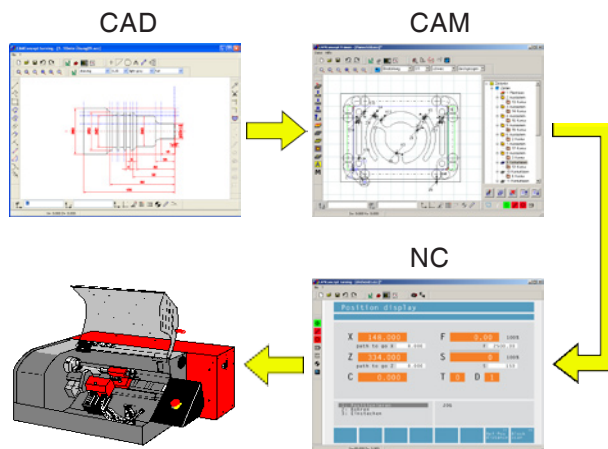

Software description EMCO CAMConcept Turning

Ref. no. EN 1829
Edition C 2009-10

This instruction manual is also available on the
EMCO homepage in electronic form (.pdf).

Original instruction manual

EMCO Maier Ges.m.b.H.
P.O. Box 131
A-5400 Hallein-Taxach/Austria
Phone ++43-(0)62 45-891-0
Fax ++43-(0)62 45-869 65
Internet: www.emco.at
E-Mail: service@emco.at





Note:

This software description contains a description of all functions which can be carried out with CAMConcept.
Depending on the machine you are running with CAMConcept, not all of these functions will necessarily be available.

All rights reserved, duplication is permitted only by prior authorisation of EMCO MAIER.
© EMCO MAIER Gesellschaft m.b.H., Hallein

CAMConcept didactics

Today, NC machines are programmed in practice via automatic contour programming. Nonetheless, it is still necessary for experts in the field to understand the automatically generated NC program.

CAMConcept offers a consistent didactic concept, starting from the simple generation of workpiece contours in CAD mode, through automatic, interactive generation of the NC program in CAM mode right up to execution of the NC program on a connected NC machine. Thanks to the fully developed online help functions, CAMConcept is perfect for training.

CAMConcept - performance scope

- Simple, graphical user interface
- Generation of CAD workpiece contours
- Adjustable clamping devices and unmachined parts
- Automatic contour programming
- Cycle support
- NC program editor
- Status indicators for the programmed machine states
- Tool library
- Import, export interfaces
- Measurement of clamping devices and tools
- Support for multiple control and machine types
- Online NC machine functions
- Online help functions
- 2D machining simulation
- 3D machining simulation

Assumed knowledge

Users working with CAMConcept are expected to be familiar with the operation of MS Windows and understand the handling and basic programming of the connected NC machine. Please consult the corresponding manuals if necessary.

Learning goals

CAMConcept teaches the following learning goals:

- Drawing and modifying CAD contours
- Automatic, interactive generation of NC programs
- Modification of existing NC programs
- Understanding the connections between the NC machine settings and NC programming
- Remote operation of an NC machine

Structure of the literature

The CAMConcept software description has the following structure:

- General basic principles of operation
- Description of the menu bars
- CAD commands
- CAM commands
- NC commands
- Operations scheduling

With its comprehensive user guidance (online help and explanations in the status bar) CAMConcept is designed so that the software description is only rarely needed.

Contents

CAMConcept didactics	3	D: CAD Commands	D1
CAMConcept - performance scope	3	CAD mode	D1
Assumed knowledge	3	Redraw	D1
Learning goals	3	Coordinates menu	D2
Structure of the literature	3	Cartesian / polar coordinate systems	D2
		Insert point	D4
A: Basic principles	A1	Catch mode and snap points	D4
Launching CAMConcept	A1	Diameter / radius input	D5
Help function	A1	Set zero point	D5
CAD screen layout	A2	Cancel zero point	D5
CAM screen layout (cycles)	A3	Ruler	D5
Window divisions	A4	Contour mirroring activated / deactivated	D6
		Creating elements	D8
B: Operating sequences	B1	Point menu	D8
Command symbols	B1	General	D8
Undo / Redo	B1	Point	D8
Zoom commands	B2	Cross-shaped	D8
AutoZoom	B2	Quadratic	D8
ZoomBox	B2	Circular	D8
Zoom undo	B2	Line menu	D9
Set new center	B2	Draw line	D9
Zoom in	B2	Poly line	D10
Zoom out	B2	Rectangle	D11
Layer	B3	Rotated rectangle 1 (starting point/angle/length/width)	D11
Calculator in input fields	B4	Rotated rectangle 2 (center/angle/length/width)	D11
		After the input of the center you have to enter the angle, by which the rectangle is rotated.	D11
C: Menu lines	C1	Parallel with point indication	D12
Menu "File"	C1	Parallel with distance	D12
New	C1	Perpendicular	D13
Open	C1	Chamfer (length)	D13
Save	C1	Chamfer (distance/distance)	D14
Save as	C1	Tangent (point/circle)	D15
DXF import	C2	Tangent (circle/circle)	D15
DXF export	C2	Circle menu	D16
NC export	C2	Circle with circle center and radius	D16
Save image	C3	Circle with centre and point on the circumference	D17
Close	C3	Concentric circles	D18
Recently opened files	C3	Circular arc with starting point, target point and circle point	D18
Menu "?"	C4	Circular arc with starting point, target point and radius	D19
Information	C4	Circular arc with starting point, target point and center	D19
Help	C4	Insert radius	D20
		Rounding off elements	D21
		Text menu	D23
		Text at point	D23
		Text on line	D23
		Text on arc	D23
		Dimensioning menu	D25
		horizontal dimensioning	D25
		vertical dimensioning	D25
		free dimensioning	D25
		dimensioning of angles	D25
		dimensioning of diameter	D25
		dimensioning of radius	D25
		Dimension settings	D25
		Symbol menu	D27
		Creating categories	D27
		Creating symbols	D28
		Change menu	D29
		Selecting an element	D29
		Cutting an element	D29
		Trimming 1 element	D30
		Trimming with 2 elements	D31
		Creating hatching	D32
		Delete	D33

Shifting an element absolutely or incrementally	D33
Shifting and copying an element absolutely or incremental-ly	D34
Rotate	D35
Rotating and copying	D36
Mirroring.....	D37
Mirroring and copying	D38
Scaling	D39

E: CAM commands..... E1

CAM mode	E1
Restructuring	E1
Generating.....	E2
Settings.....	E2
Machine	E2
Tool measurement.....	E3
Unmachined part	E9
Entering a contour	E10
Follow contour - segments	E10
Follow contour - elements.....	E10
Save contour.....	E11
Cancel contour.....	E11
Cycles	E12
Defining cycles.....	E12
2D simulation	E13
Input of technology data	E16
Turning Cycle 1.....	E17
Turning Cycle 2.....	E19
Facing Cycle 1	E21
Facing Cycle 2	E23
Thread Cutting 1	E25
Thread Cutting 2	E28
Thread Cutting 3	E31
Multiple Gear Thread	E34
Grooving Cycle 1	E38
Grooving Cycle 2	E40
Grooving Cycle 3	E42
Grooving Cycle 4	E45
Cut-Off Cycle	E48
Contour Turning.....	E50
Drilling Cycle	E54
Tapping Cycle	E58
Positioning	E60
ISO edit.....	E62
Coordinate transformation	E64
Simulation	E66
NC start.....	E67
NC reset.....	E67
NC stop	E67
Single block on/off	E67
Alarms of the 3D simulation.....	E68
Cycle lists.....	E68
3D-simulation settings	E69
Zoom commands for the simulation.....	E71
Tool modelling with the 3D-Tool Generator	E72
Generating a new tool.....	E73
Copying a tool.....	E73
Changing an existing tool	E74
Selecting a tool colour	E74
Visualizing a tool.....	E75
Sorting function.....	E76

F: NC commands..... F1

NC part	F2
Working through the NC program.....	F2
Screen layout for an NC part	F2
NC start.....	F3
NC reset.....	F3
NC stop.....	F3
Single block ON/OFF	F3
Dry run	F3
Machine referencing	F3
Block scan	F4
Periphery	F5
Spindle anti-clockwise	F5
Spindle stop	F5
Spindle clockwise	F5
Open / close clamping device.....	F5
Mandrel forwards / back	F5
Blowing-out device ON/OFF	F5
Open / close automatic door	F6
Coolant ON/OFF	F6
Next tool.....	F6
Auxiliary drives ON/OFF	F6
Feed rate F [mm/min]	F7
Spindle speed S [rpm]	F8
Constant cutting speed CSS [m/min].....	F9
Traversing coordinate axes	F10
Setting / resetting a reference point.....	F10
Loading a new tool.....	F10

G: Operations scheduling.....G1

Operations scheduling.....	G2
Print tool table.....	G2
Print plans.....	G2
Plane setting	G3

H: Alarms and Messages.....H1

Machine Alarms 6000 - 7999.....	H1
PC MILL 50 / 55 / 100 / 105 / 125 / 155.....	H1
Concept MILL 55 / 105 / 155	H1
PC TURN 50 / 55 / 105 / 120 / 125 / 155.....	H6
Concept TURN 55 / 105 / 155 / 250	H6
Concept MILL 250	H6
EMCOMAT E160	H6
EMCOMILL C40	H6
Axis Controller Alarms	H13
Axis Controller Messages.....	H18

Control alarms 2000 - 5999	H19
Fagor 8055 TC/MC	H19
Heidenhain TNC 426	H19
CAMConcept	H19
EASY CYCLE	H19

X: EmConfig..... X1

General	X1
How to start EmConfig.....	X2
How to activate accessories	X3
How to save changes	X3
How to create machine data floppy disk or machine data	
USB flash drive	X3

Z: Software Installation..... Z1

System requirements.....	Z1
Software installation.....	Z1
Variants of WinNC	Z1
Settings of the Interface Board	Z2
RS 485 - Board (AC88).....	Z2
PCCOM (RS 422) - Board (AC95).....	Z4
Network card (ACC).....	Z6
Starting WinNC	Z10
Closing WinNC	Z10
Licence input.....	Z11
License manager	Z11

cuu duong than cong . com

A: Basic principles

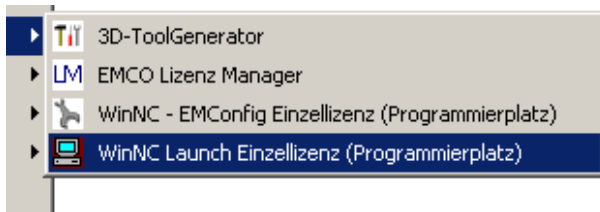

Launching CAMConcept

Launching CAMConcept

At this point we would like to refer the reader to the general aspects of Windows XP operation, which are not covered in this brochure. For more information please refer to the corresponding manuals for your operating system.

After Windows installation of CAMConcept, point the mouse at the WinNC Launch program icon (in the Windows Start menu) and click on it.

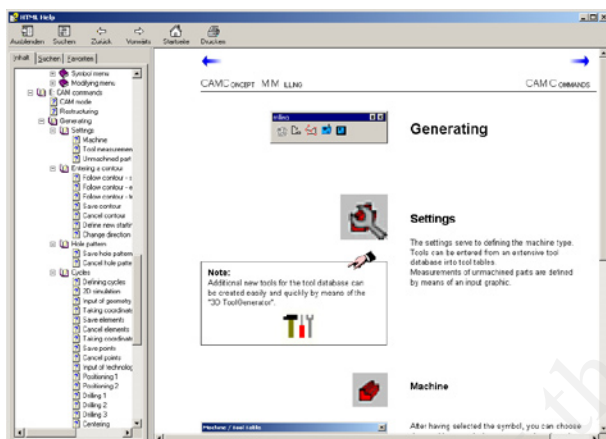

CAMConcept help with Contents pane

Help function

CAMConcept offers several online help functions which will provide the required assistance in any step:

- The full CAMConcept help function, which can be called up via the menu bar. This function offers a content listing which enables you to scroll back and forward through all of the help texts in the same way as you are used to from other Windows programs.
- CAMConcept keeps you constantly informed in the status bar at the bottom of the screen. Here you can see what kind of inputs CAMConcept is expecting from you.
- The CAMConcept help field (Shift + F1), which takes you directly to the required help.
- When you hover over a function with the mouse pointer, CAMConcept displays the name of the function.

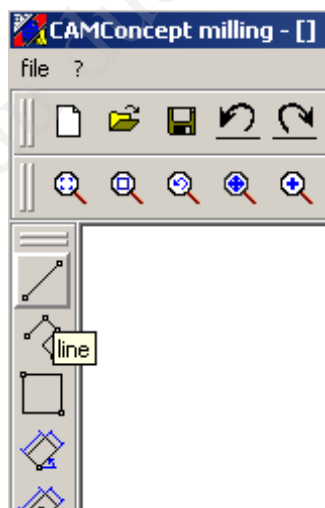

Name of the function

CAD screen layout

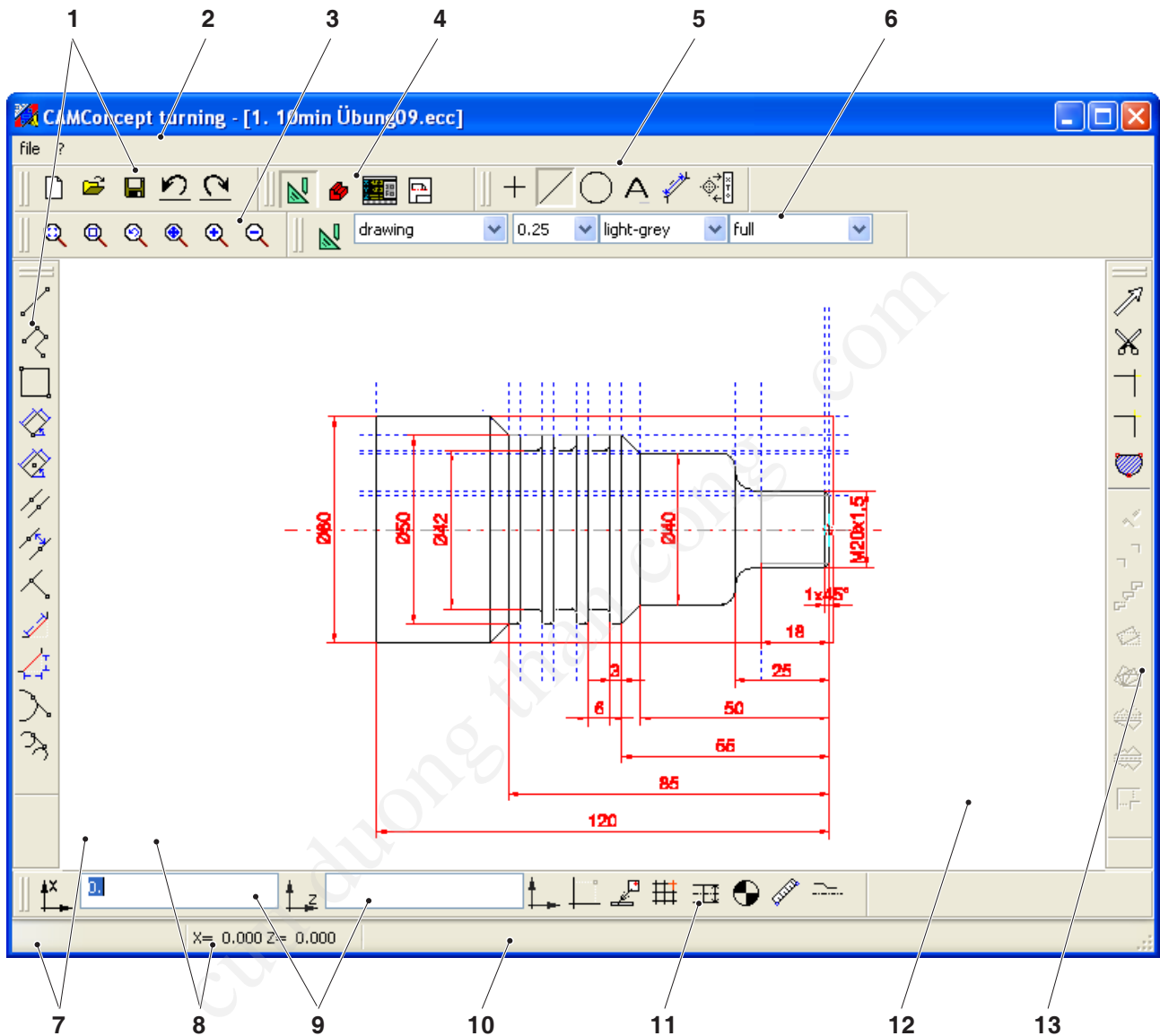

No.	Description	No.	Description
1	Command symbols	8	Previous position message
2	Menu bar	9	Input fields
3	Zoom commands	10	Status message / Help bar / Error message
4	Switchover between CAD-CAM-NC-AV modes	11	Coordinates menu
5	CAD menu commands	12	CAD window
6	Layer	13	Change commands
7	Current position message		

CAM screen layout (cycles)

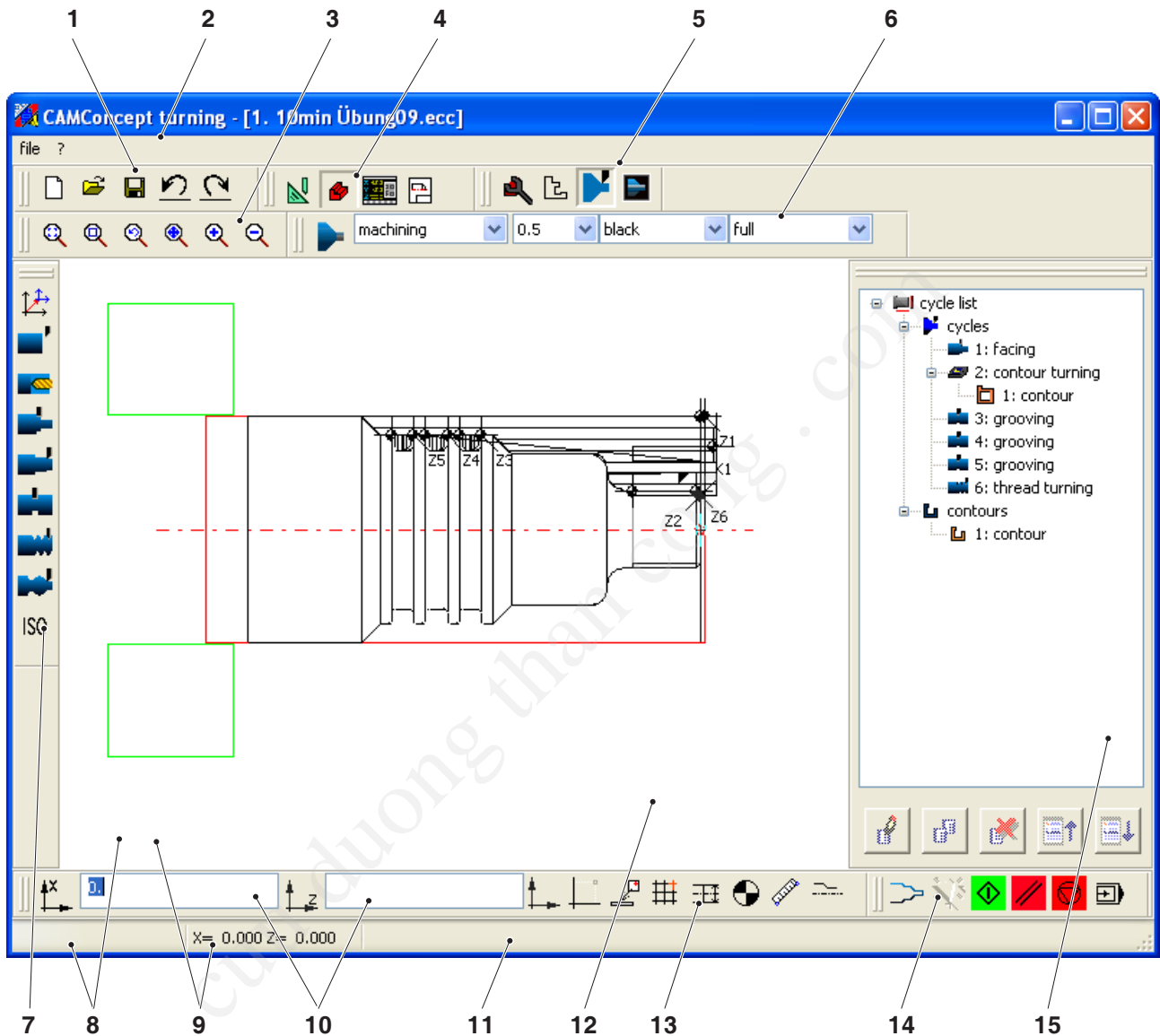

No.	Description	No.	Description
1	Command symbols	9	Previous position message
2	Menu bar	10	Input fields
3	Zoom commands	11	Status message / Help bar / Error message
4	Switchover between CAD-CAM-NC-AV modes	12	CAM window
5	CAM menu commands	13	Coordinates menu
6	Layer	14	2D simulation
7	Cycle commands	15	CAM editing window
8	Current position message		

Window divisions

CAMConcept main window

After having been started, CAMConcept will appear with its main window. In the working area of the main window additional windows are possible.

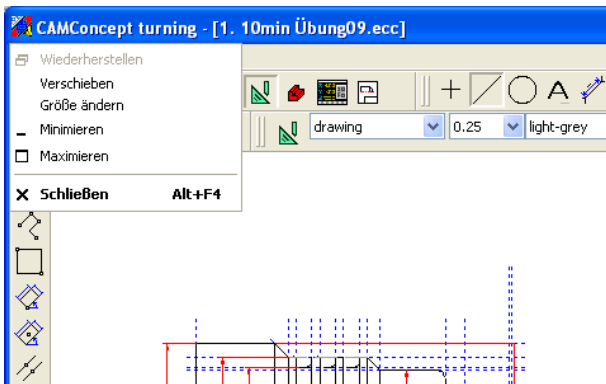

CAMConcept main window

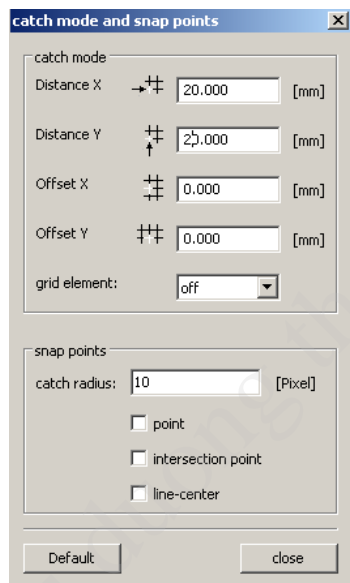

CAMConcept window

CAMConcept window

CAMConcept windows serve to either provide information (e.g. information about CAMConcept) or to enter specific parameters (e.g. properties of lines). These windows can only be moved.

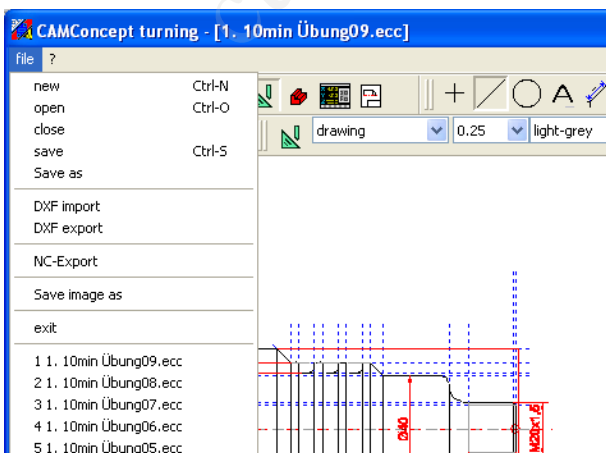

Menu name

Menu lines

By clicking on a menu name a list of commands that can be selected (standard font) and of those being currently blocked (diffuse, matrix font) will be displayed.

B: Operating sequences

You can maximize, minimize windows or go back to normal window size by means of the window symbols. Make a double click on the text display of the status line to switch between the normal and the maximized window size.

Command symbols

Display of symbols

When you have selected a command symbol with the mouse button (which means it is active), the symbol appears shaded.



Icon inactive



Icon active

The symbol will remain active until

- the command is carried out (direct command symbols).
- the command is deselected by another one (menu commands and shift symbols).
- the command is cancelled by pressing the right mouse key.

Note:

Press the right mouse button when you wish to return to the respective superordinate menu.

It is possible to change the properties of an element later in the CAD mode by means of the right mouse button.



Undo / Redo

Use the symbol "Undo" to cancel the last operating commands.

The symbol "Redo" enables to cancel already cancelled operating commands.



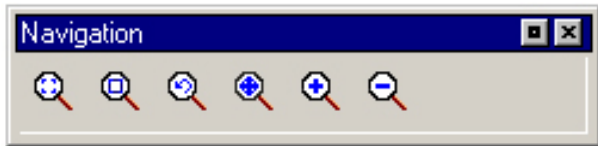

Zoom commands

The navigation bar enables to zoom and move the simulation image. Prior to selecting a symbol, press the left mouse button in the drawing window once.

AutoZoom

Zooms the display area automatically in or out to window size.



ZoomBox

After selection of the symbol use the mouse to draw a selection rectangle around the elements you wish to zoom in and press the left mouse button.



Zoom undo

You can cancel the last zoom command by means of the command "Zoom undo".



Set new center

After selection of the symbol the mouse pointer changes into a 4-way arrow. Use the mouse to select the new center of the drawing. The drawing will be centered around the drawing center that has been selected.



Zoom in

After selection of the symbol the view is zoomed in by one step. You can also use the mouse wheel or the key to zoom in.

If you wish to make extensive magnifications, it is easier to use the symbol "ZoomBox".



Zoom out

After selection of the symbol the view is zoomed out by one step. You can also use the mouse wheel or the key to zoom out.

If you wish to make extensive reductions, it is easier to use the symbol "AutoZoom".

Layer

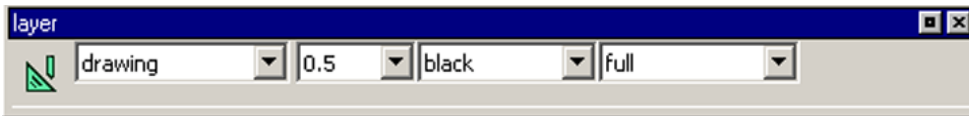

Layer selection window in CAD mode

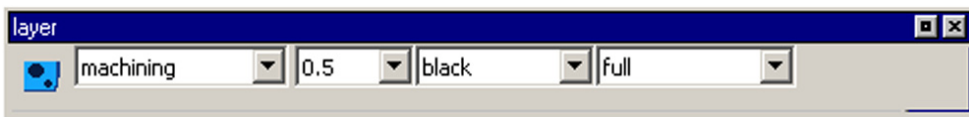

Layer selection window in CAM mode

The layer window enables the definition of different line attributes.

You can choose among several layers.

Here you can set the line width, the line colour and the line form of the lines being displayed in the CAD, respectively in the CAM mode.

Prior to drawing the elements, please select the line attributes.

In the CAD mode you can later alter the properties of an element by means of the right mouse button.

Calculator in input fields

With the aid of the calculator, mathematical expressions can be calculated directly in an input field.

Any number of parenthesis levels can be used in the expressions.

To calculate the expressions, press the "Enter" key or exit the input field.

In the event of errors during calculation of a formula, the last entered expression is displayed and CAMConcept outputs an error message.

Command	Meaning	Example	Result
+	Addition	1+1	2
-	Subtraction	3-2	1
*	Multiplication	5*3	15
/	Division	15/3	5
%	Modulo function (division remainder)	10%4	2
^	Power	5^2	25
PI	Pi; the ratio of the circumference of a circle to its diameter	PI	3.141593
SIN()	Sine function	SIN(90)	1
ASIN()	Arc sine function	ASIN(-1)	-90
COS()	Cosine function	COS(90)	0
ACOS()	Arc cosine function	ACOS(-1)	180
TAN	Tangent function	TAN(45)	1
ATAN	Arc tangent function (value)	ATAN(1)	45
ATAN2(;)	Arc tangent (X-section; Y-section)	ATAN(0;1)	0
EXP()	Exponential function (base e)	EXP(1)	2,718282
LOG()	Logarithm function (base e)	LOG(5)	1,609
SQRT()	Square root function	SQRT(2)	1,414
MOD(;)	Modulo function	MOD(10;4)	2
TRUE	Logically true	TRUE	1
FALSE	Logically false	FALSE	0
AND	AND operation	1AND1	1
OR	OR operation	1OR1	1
NOT	Negation	NOT(1OR1)	0

Calculator functions

C: Menu lines

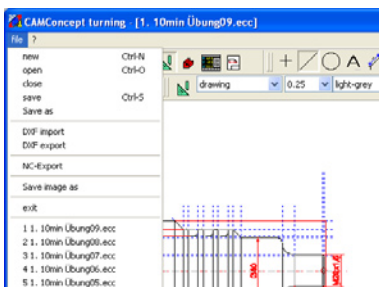

Menu "File"

New

Click on this symbol to open a new project. In case there is a drawing already being displayed on the screen, it will either be saved or deleted after a safety query.



Menu "File"

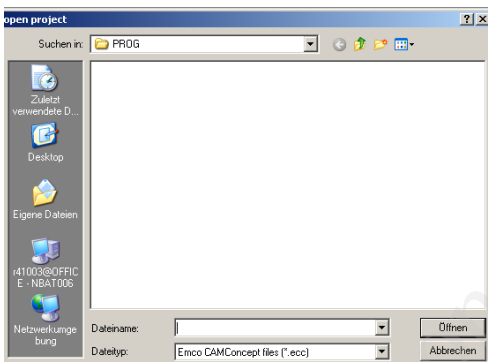

Open

With "Open" an existing project file will be opened. The Windows file window appears on the screen for the selection of CAMConcept project files. In case there is a project already being displayed on the screen, it will either be saved or deleted after a safety query.



Menu "Open file"

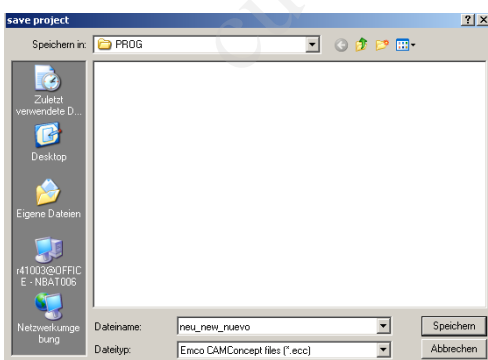

Save

The whole project is automatically saved under the same file name, under which it has been opened. For a new project that has not been saved yet, the Windows file window is automatically opened for input, respectively selection (see "Save as").

Save as

With this menu the whole project is saved under a new file name. The Windows file window appears for input, respectively selection.

Menu "Save file"



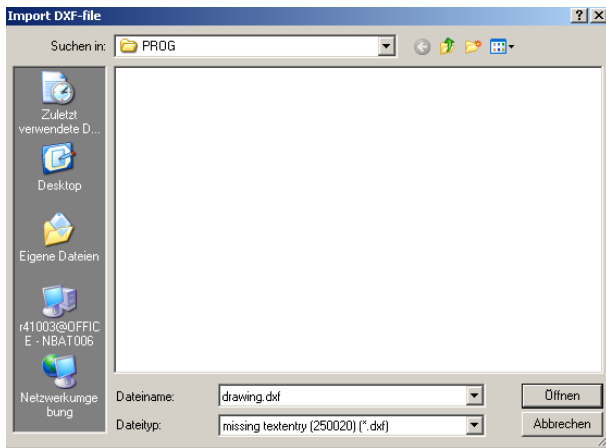

Menu "File, DXF import"

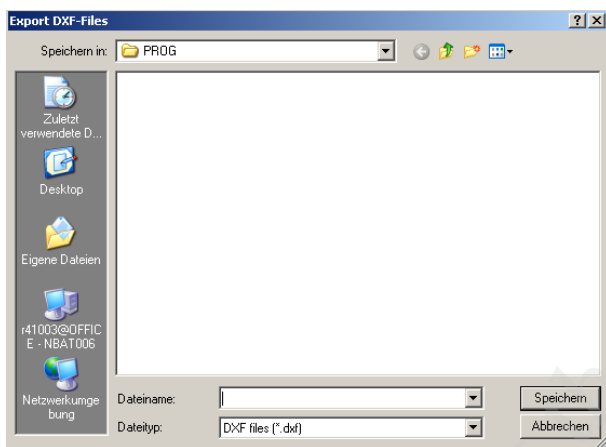

Menu "File, DXF export"

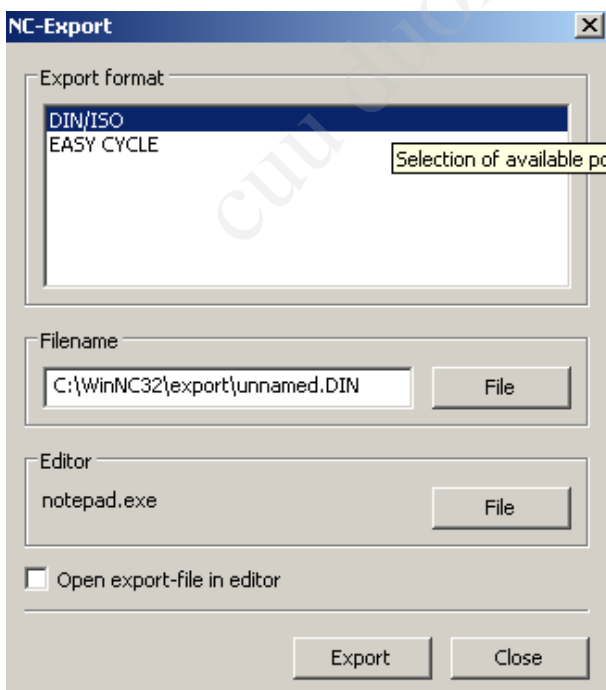

Menu "File, NC export"

DXF import

With DXF import DXF files can be directly called into the CAD mode, where they can be edited.

Note:

It is not possible to import splines.

DXF export

DXF export enables to convert a drawing that was created in the CAD mode into a DXF file.

NC export

This is used to export an NC program. Choose the correct export format. Specify the file name for the export file. Choose the editor with which the exported file is to be opened for further processing. Choose whether the export file should be opened in the editor after exporting.

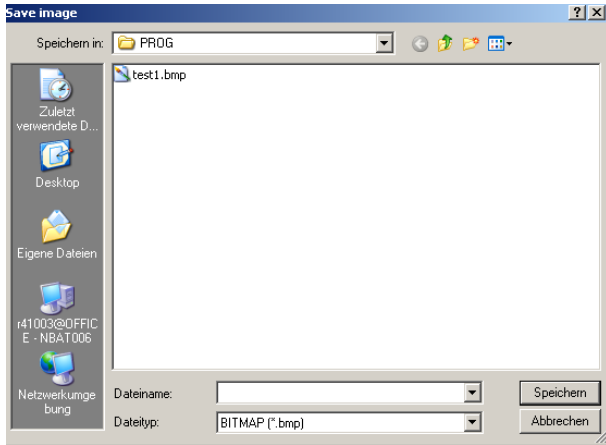

Menu "File; Save image"

Save image

This is used to save a screenshot of the drawing. A Windows file window pops up in which the file name can be entered and the image format can be selected.

The image can be saved as one of the following file types: *.bmp, *.jpg or *.png.



Menu "Close file"

Close

After a safety query the CAMConcept window will be closed and the program will be terminated.

Other possibilities to terminate the program are to close the CAMConcept window by pressing ALT+F4 or to end the task. For detailed information please consult your Windows manual.

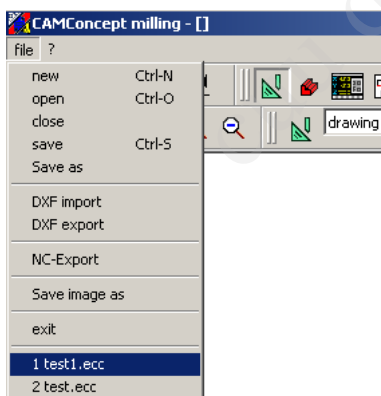

Menu "File; Recently opened files"

Recently opened files

At the bottom of the "File" menu you will see a list of the files you have opened most recently with CAMConcept.

You can click on these with the mouse to open them directly.

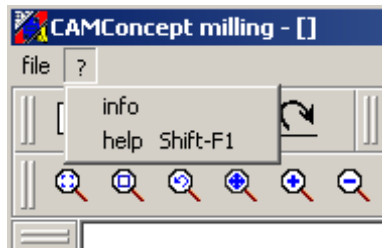

Menu "?"

Menu "?"

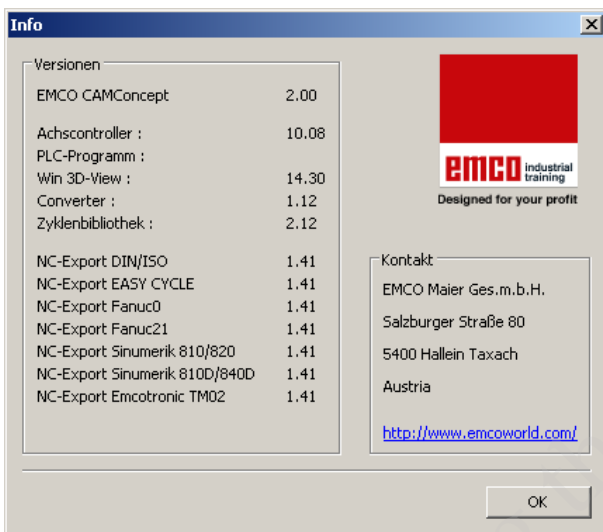

Menu "?", Information

Information

The CAMConcept information window pops up with the software version number.

Note:

The number and values of the displayed version numbers may vary according to the configuration of the program and the selected machine.

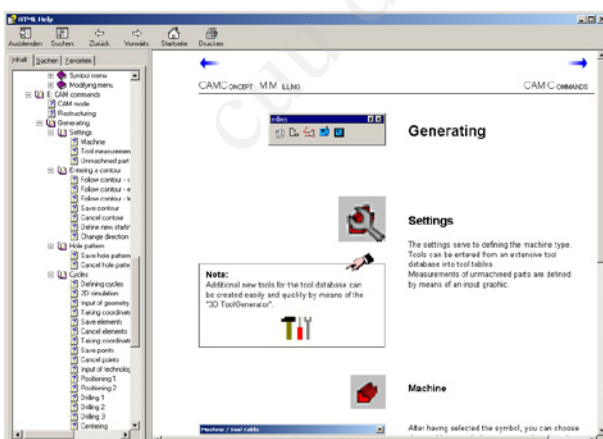

Menu "?", Help

Help

The CAMConcept help window opens here. You can scroll through the help pages with the aid of the cursor keys or by clicking on the blue arrows, or alternatively you can also use the contents pane to search for a keyword.

Use the "Search" tab to find a keyword in the help function. Enter the word in the text box and click on "Search".

You can also call up the help function directly by pressing Shift + F1.

D: CAD Commands

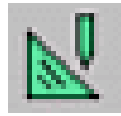

CAD mode

The CAD command symbols are activated by clicking on the shift symbol "CAD". The CAD mode will remain active until it is deselected by CAM, NC or operations scheduling. After the start of CAMConcept the CAD mode will be automatically activated.

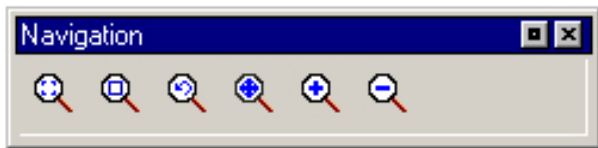

The zoom commands are described in chapter B.

Note:

You return to the respective superordinate menu by pressing the right mouse button. In the CAD mode the properties of an element can be changed later by means of the right mouse button.

Note:

Please confirm all value entries with "ENTER".



Redraw

The screen is redrawn after the F5 key is pressed.

After using the "Delete" or "Change" functions, it is possible that some lines on the screen are only displayed incompletely. In this case you should use the "Redraw" function or the zoom commands in order to refresh the screen display.

Coordinates menu

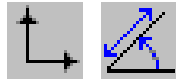

Cartesian / polar coordinate systems

If the production drawing is dimensioned with rectangular coordinates, then you should also create the editing program with rectangular coordinates.

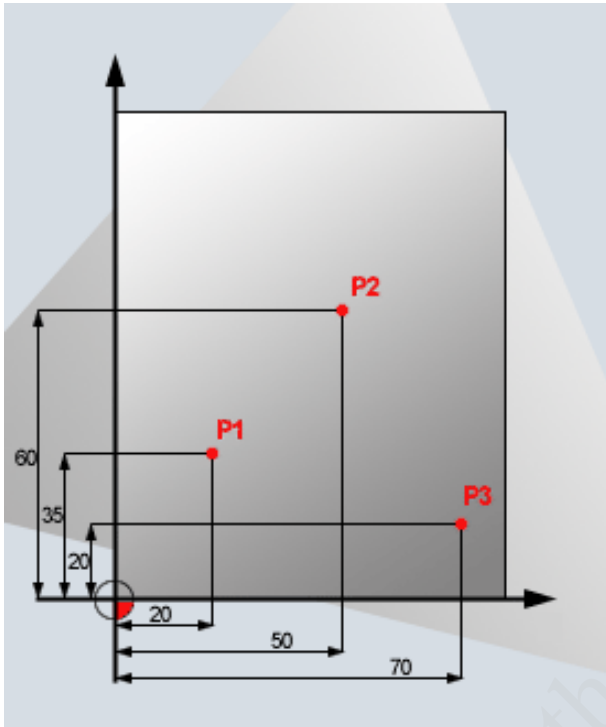

Cartesian coordinate systems

Example:
 P1: X35 Z20
 P2: X60 Z50
 P3: X20 Z70

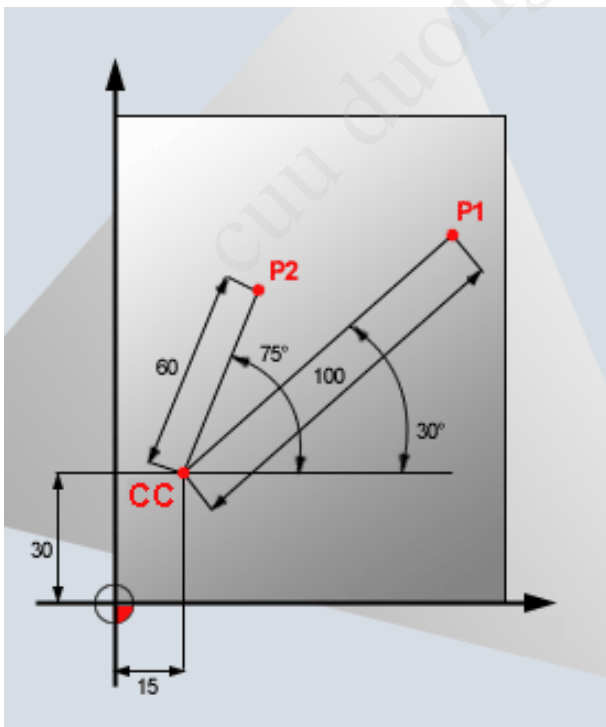

Polar coordinate systems

On workpieces with circular arcs or in cases where angles are specified it is often easier to define the position with polar coordinates.

The zero point of a polar coordinate system is in the pole CC (CC = circle centre). A position in a plane is also uniquely defined by:

- Radial coordinate: the distance from the pole CC to the position
- Angular coordinate: the angle between the polar axis and the line between the pole CC and the position.

Example:
 P1: Radius=100 Angle=30°
 P2: Radius=60 Angle=75°

Absolute and incremental positioning

Absolute Cartesian position



If the coordinates in a position relate to the zero point of the coordinate system (origin) then they are referred to as absolute coordinates. Every position on a workpiece is uniquely defined by its absolute coordinates.

Incremental Cartesian position



Incremental coordinates relate to the last programmed position.

Absolute polar coordinates



Absolute coordinates always relate to the pole and the polar axis.

Incremental polar coordinates



Incremental coordinates always relate to the last programmed position. The polar axis is always a horizontal (+Z axis).



Insert point

After selection of the symbol the current position message will be entered into the input box.



Catch mode and snap points

Grid elements or grid lines are inserted to support the orientation and the drawing process. The grid starts in the reference point. The grid elements or the grid lines have the distances in horizontal and vertical direction as indicated in the input box shown opposite.

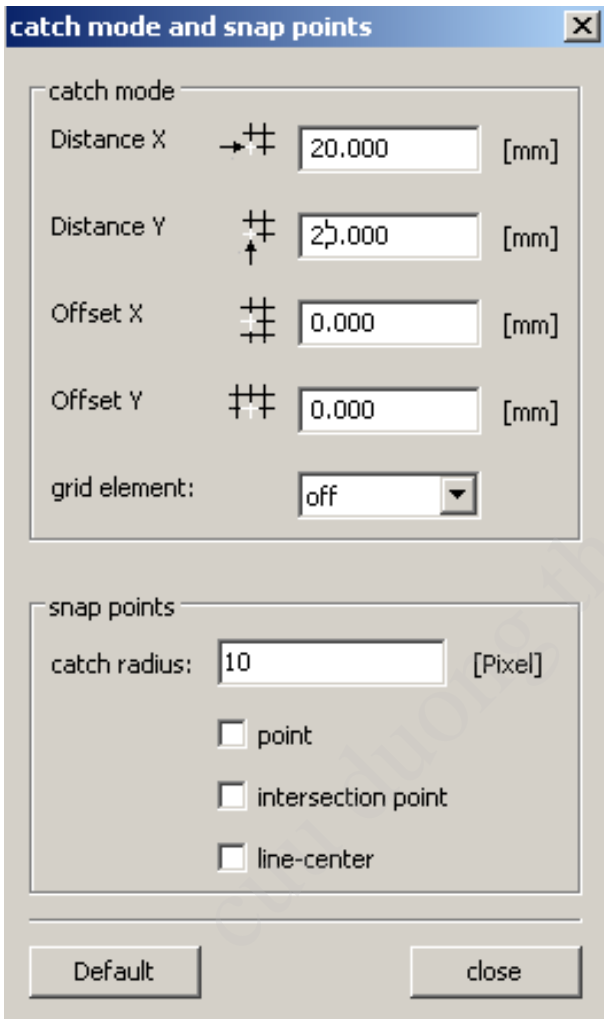

A grid that has already been defined can be additionally shifted vertically and/or horizontally. The grid can be displayed either as lined, dotted or inactive grid.



Catch radius

The catch radius is the area around the cursor cross which is searched by CamConcept when selecting elements.

Enter the catch radius in the input box.

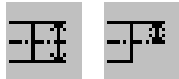

Diameter / radius input

With the aid of these icons CAMConcept switches over between diameter programming and radius programming.

Diameter input

The diameter is entered as the value of the X-coordinate. All position messages for the X-coordinate refer to the diameter value.

Radius input

The radius is entered as the value of the X-coordinate. All position messages for the X-coordinate refer to the radius value.



Set zero point

The CAD zero point is automatically set in the center of the drawing window.

This function enables to shift the zero point and thus the coordinate system from its present position.

After selection of the symbol use the left mouse button to position the new zero point at the required position.



Cancel zero point

When you select this symbol, the zero point that has been set will be cancelled



Ruler

The ruler serves to measuring the geometrical data in the CAD mode.

After selection of the symbol a window as shown in the illustration opposite will appear.

Press the left mouse button to select the starting point and the end point of the length to be measured.

Measuring distance between 2 points [X]

Measuring points

Startpoint P1

X Z

Endpoint P2

X Z

Result

Distance [mm]

Angle [degree]

close

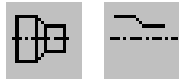

Contour mirroring activated / deactivated

Only elements along the mirror axis are mirrored which are completely above the mirror axis (Z+) and within the dimensions of the unmachined part. Visible edges are shown in addition.

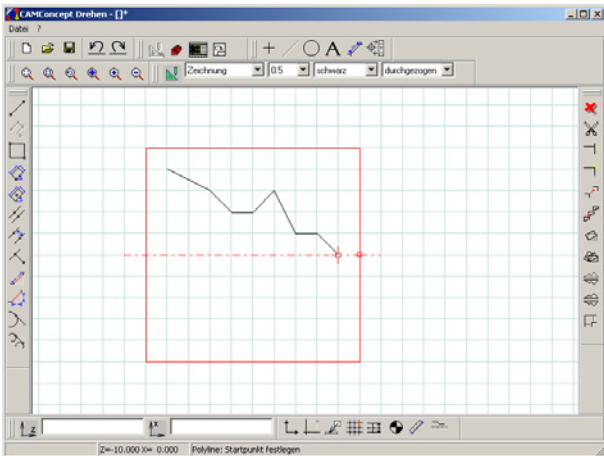

Contour mirroring deactivated

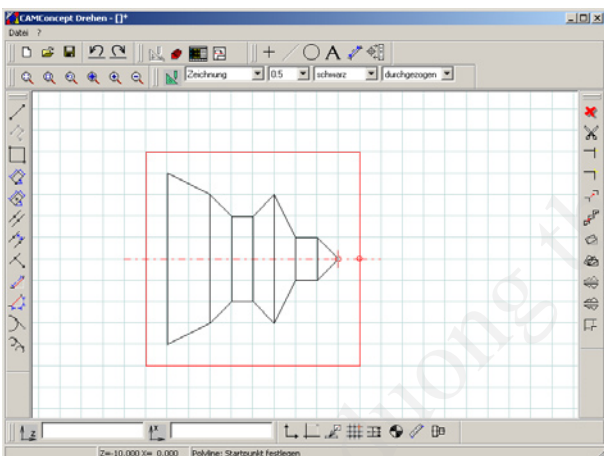

Contour mirroring activated

cuu duong than cong . com

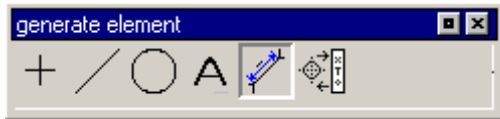

Creating elements

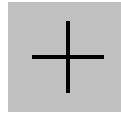

Point menu

General

After having selected the respective point symbol, please enter the position. This can be carried out by one of the following ways:

1. present cursor position and mouse click
2. by means of the the catch-mode menu (see catch grid and snap points) and mouse click
3. input of coordinates (see coordinate menu)

Every point will be saved as design point.



Point



Cross-shaped



Quadratic



Circular

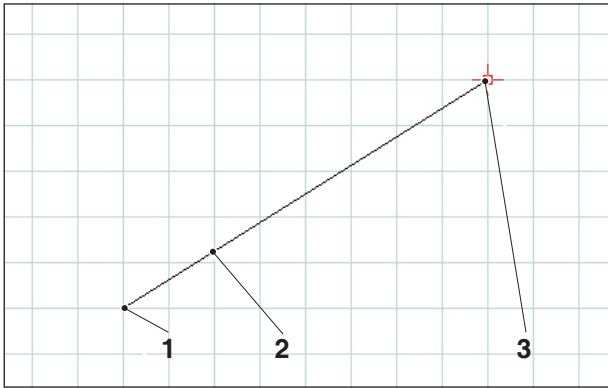
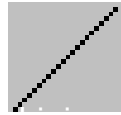

Drawing a line

Line menu

Draw line

After having selected the symbol, you have to enter the starting point of the line. This can be carried out by one of the following ways:

1. present cursor position and mouse click
2. by means of the catch-mode menu (catch grid and snap points) and mouse click
3. input of coordinates (see coordinate menu)

Then you have to enter the target point of the line.

The starting point and the target point of each line will be saved as construction points. If you have to draw several lines that are connected with each other, you better use the command "poly line".

Item	Description
1	Starting point
2	Drawn line
3	End point

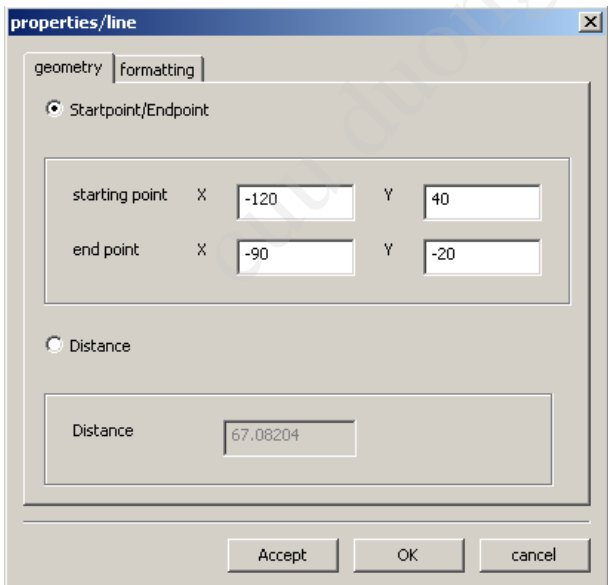

Line properties window

Line properties window

Note:

With the key combination CTRL + right-hand mouse button you can call up the properties window (Lines) and retrospectively change the line properties.

In the "Geometry" tab you can

- change the starting point/end point of the line by entering the coordinates. The length of the line is recalculated when the "Accept" button is pressed.

or

- change the properties of the line by entering the line length. The starting point remains the same, and the end point is shifted by the indicated value without changing the direction of the line.

The coordinates of the line are recalculated when the "Accept" button is pressed.

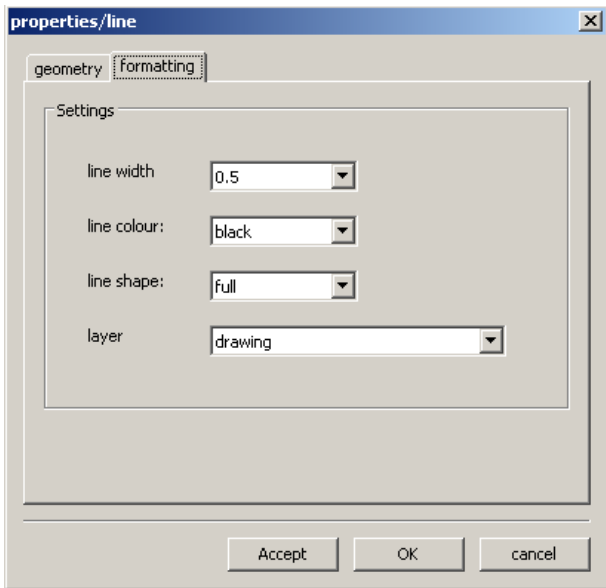

In the "Formatting" tab you can modify the following properties of the line:

- Line width
- Line colour
- Line shape
- Layer

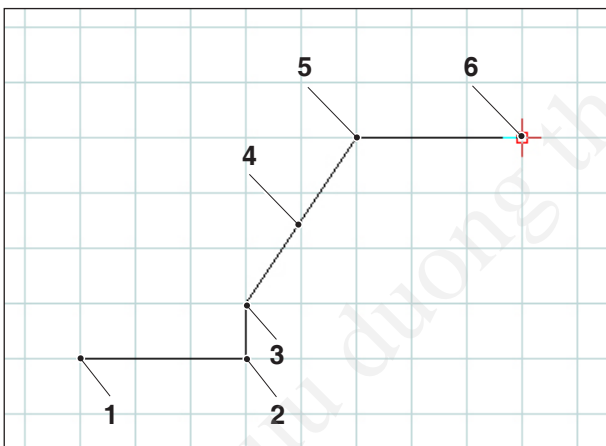

Poly line

Poly line

After the input of the starting point you have to enter the first target point. The first line of the poly line (polygon) will be drawn immediately. Now the command waits for the input of the next target point and so on.

Every point entered will be saved as design point.

The command is selfholding and must be interrupted (other command symbol, or press right mouse button).

Item	Description
1	Starting point
2	Point 1
3	Point 2
4	Polyline
5	Point 3
6	Point 4

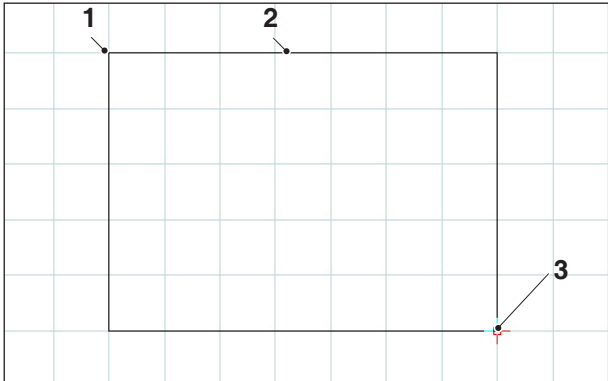

Rectangle

Rectangle

After the input of the starting point you have to enter the end point. The rectangle will be drawn immediately. Now the command waits for the input of the next starting point and so on.

Every point entered will be saved as design point.

Item	Description
1	Starting point
2	Rectangle
3	End point

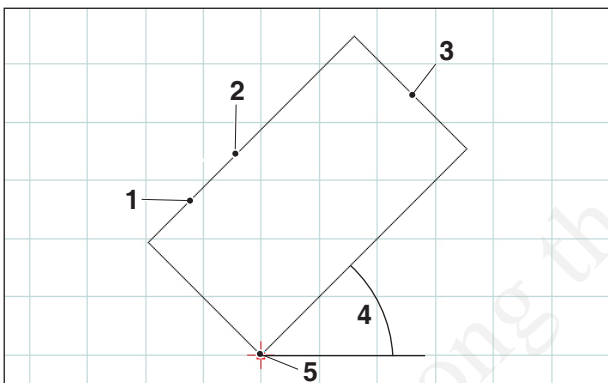

Rotated rectangle 1

Rotated rectangle 1 (starting point/angle/length/width)

After the input of the starting point you have to enter the angle, by which the rectangle is rotated. Then, please enter the length and the width of the rectangle.

Every point entered will be saved as design point.

Item	Description
1	Length
2	Rotated rectangle 1
3	Width
4	Angle
5	Starting point

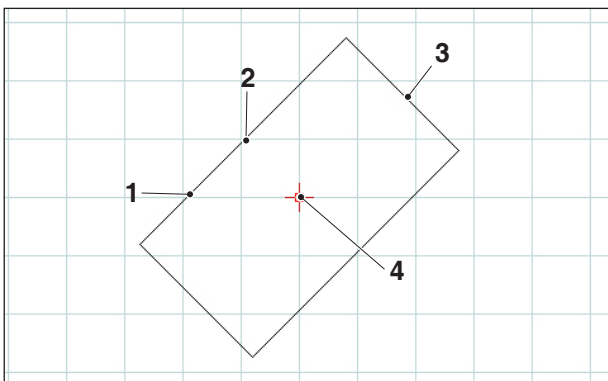

Rotated rectangle 2

Rotated rectangle 2 (center/angle/length/width)

After the input of the center you have to enter the angle, by which the rectangle is rotated. Then, please enter the length and the width of the rectangle.

Every point entered will be saved as design point.

Item	Description
1	Length
2	Rotated rectangle 2
3	Width
4	Centre

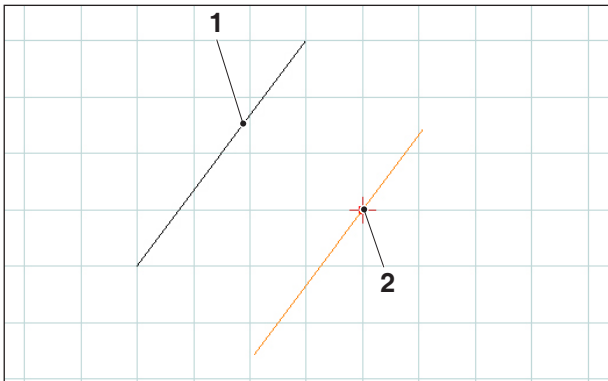

Parallel with point indication

Parallel with point indication

After having chosen the symbol, please select the element to be copied in parallel. The selected element changes its colour. Then you have to define a point across which the parallel shall run.

Both translated end points of the lines will be saved as design points.

Item	Description
1	Existing line
2	Parallel line through point

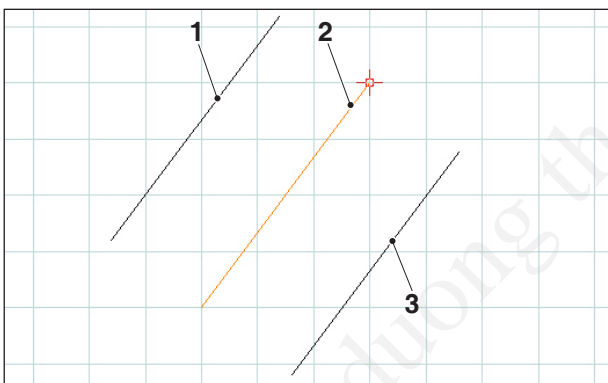

Parallel with point indication

Parallel with distance

After having chosen the symbol, please select the element to be copied in parallel. The selected element changes its colour. Then you have to enter the distance which the parallel shall observe.

Since we have two possible parallel lines here, you have to define the required parallel by entering an arithmetic sign (parallel 1 with a negative sign and parallel 2 with a positive one).

Both translated end points of the lines will be saved as design points.

Item	Description
1	Parallel line 1
2	Existing line (selected)
3	Parallel line 2

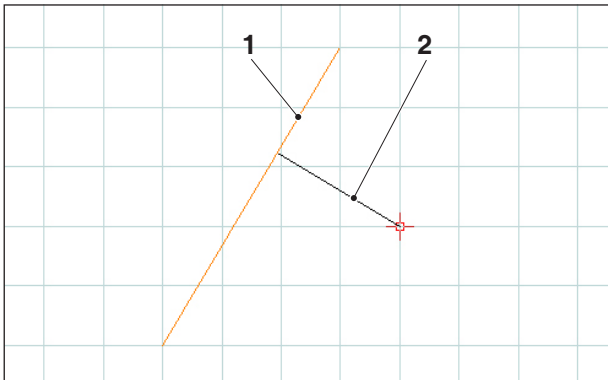

Perpendicular

Perpendicular

After having chosen the symbol, please select the element to be copied in parallel. The selected element changes its colour. Then you have to define a point across which the parallel shall run.

Both translated end points of the lines will be saved as design points.

Item	Description
1	Existing line (selected)
2	Perpendicular

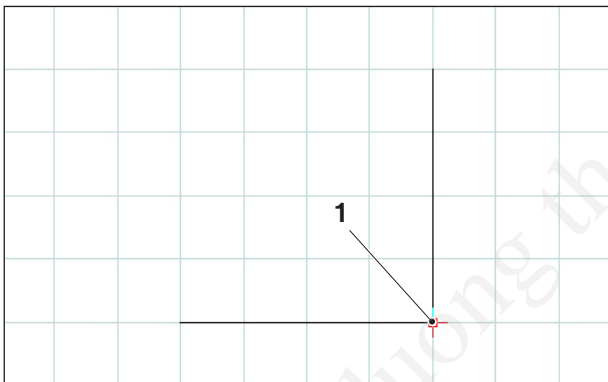

Edge point to be chamfered

Chamfer (length)

After having chosen the symbol, you have to select the lines where chamfer shall be inserted. The selected elements change their colour. Then you have to enter the length of the chamfer.

The two new design points resulting from the chamfer edge points will be saved. The previous edge point will be deleted.

Item	Description
1	Corner point
2	Chamfered corner point
3	Length of the chamfer

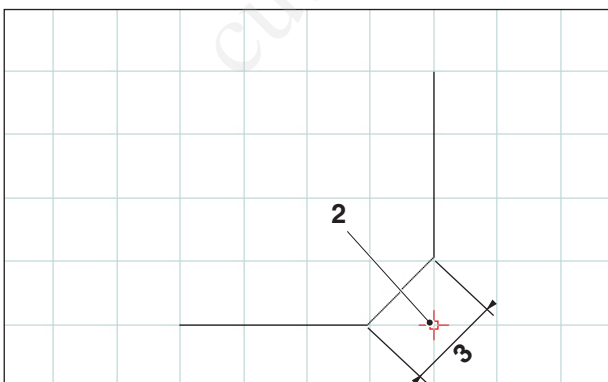

Chamfered edge point



Chamfer (distance/distance)

After having chosen the symbol, you have to select the lines where the chamfer shall be inserted. The selected elements change their colour. Then you have to enter the length of the chamfer in axis direction.

The two new design points resulting from the chamfer edge points will be saved.

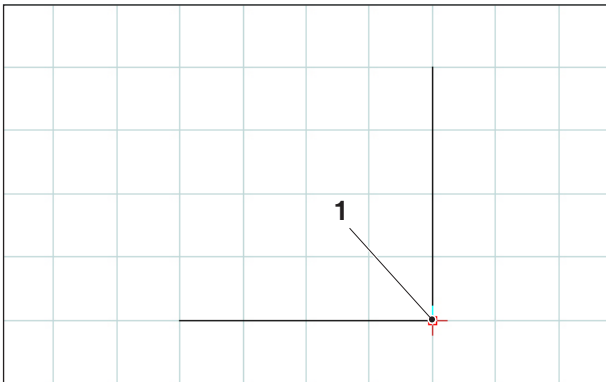

Edge point to be chamfered

Item	Description
1	Corner point
2	Chamfered corner point
3	Length of the chamfer in the direction of the axis

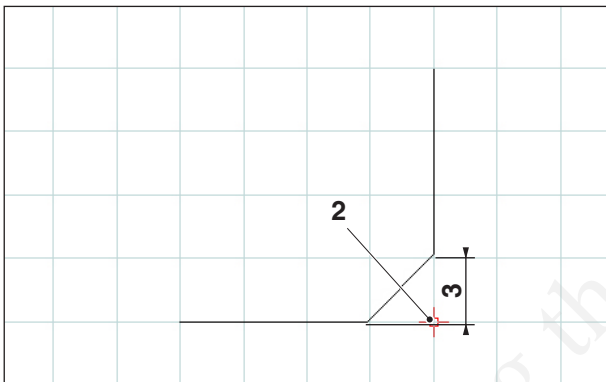

Chamfered edge point

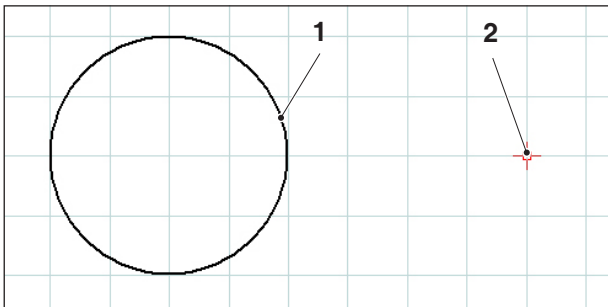

Tangent point - circle

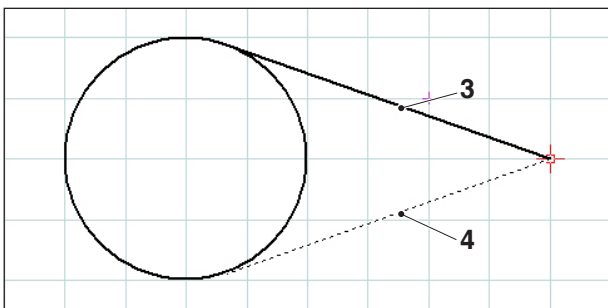

Possible tangents

Tangent (point/circle)

After having chosen the symbol, you have to select the circle element and then define the point across which the tangent shall run. The selected elements change their colour.

Now the two possibilities for selection are displayed. The selected tangent is shown as a full line, the possible tangent as a dashed line. Use the left mouse button to select one possibility.

The two end points of the tangent will be saved as design points.

Item	Description
1	Circle element
2	Point
3	Selected tangent
4	Possible tangent

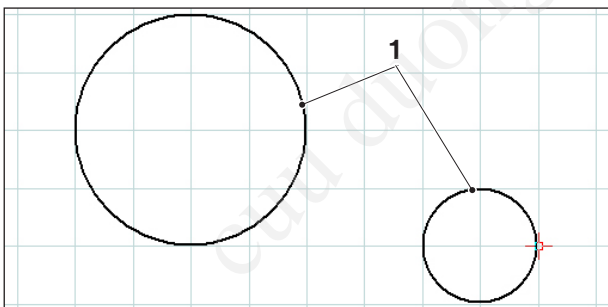

Tangent circle - circle

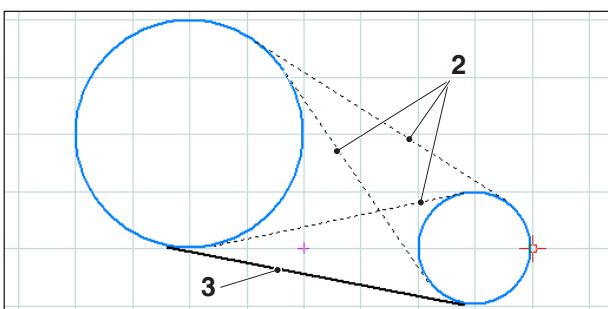

Possible tangents

Tangent (circle/circle)

After having chosen the symbol, you have to select the two circle elements between which the tangent shall be drawn. The selected elements change their colour.

Now four possible tangents are displayed for selection. The selected tangent is shown as a full line, the possible tangents as dashed lines. Use the left mouse button to select a possibility.

The two end points of the tangent will be saved as design points.

Item	Description
1	Circle elements
2	Possible tangents
3	Selected tangent

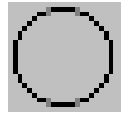

Circle menu



Circle with circle center and radius

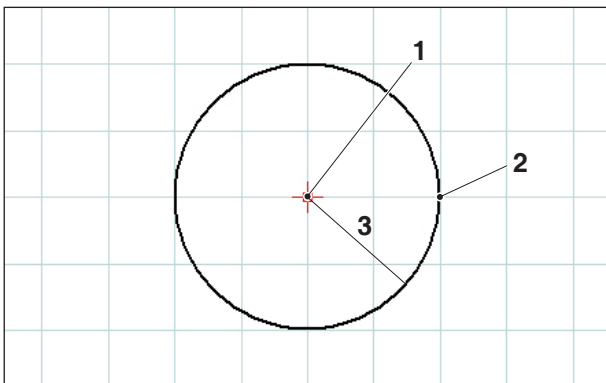

Circle with center and radius

After having selected the symbol, you have to enter the circle center. This can be carried out by one of the following ways:

1. present cursor position and mouse click
2. catch-mode menu (see catch grid and snap points) and mouse click
3. input of coordinates (see coordinate menu)

Then the radius of the required circle has to be entered.

The circle center and the circle point will be saved as design points.

Item	Description
1	Centre of the circle
2	Point on the circumference of the circle
3	Radius

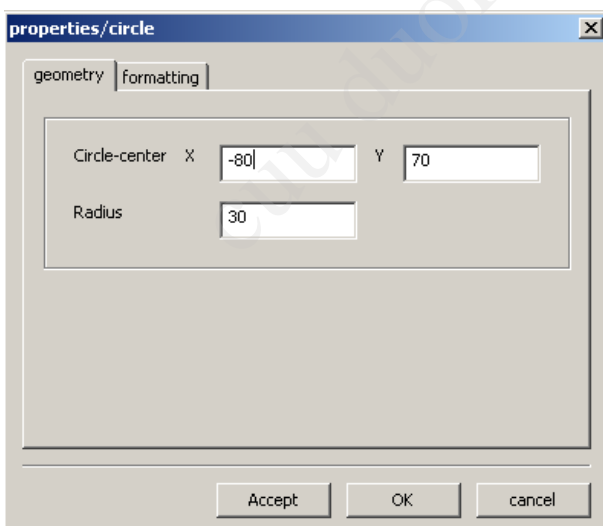

Circle properties window

Circle properties window

Note:

With the key combination CTRL + right-hand mouse button you can call up the properties window (Circle) and retrospectively change the line properties.

In the "Geometry" tab you can

- change the centre of the circle by entering the coordinates
- and change the radius of the circle.

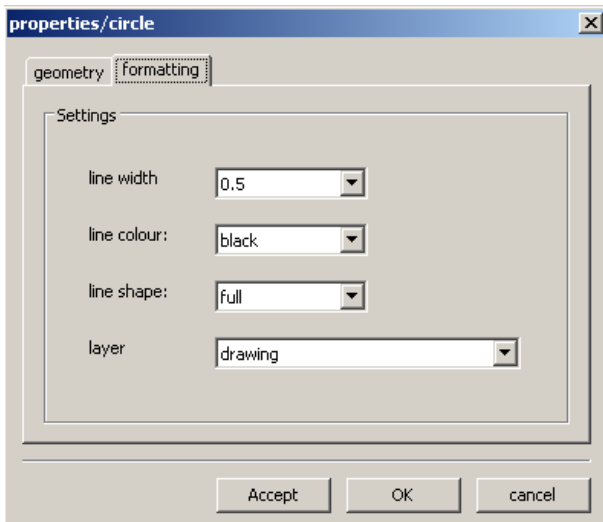

Circle properties window

In the "Formatting" tab you can modify the following properties of the circle:

- Line width
- Line colour
- Line shape
- Layer

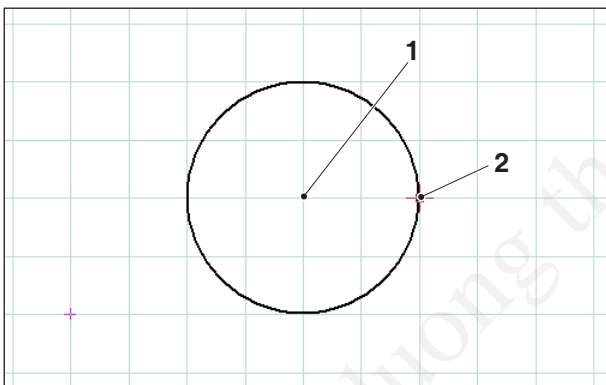

Circle with circle point and center

Circle with centre and point on the circumference

After selecting the symbol the centre of the circle should be entered. This can be done by:

1. pointing the cursor at the desired point and clicking on the mouse
2. using the catch mode menu (see catch grid and catch points) and clicking on the mouse
3. entering the coordinates (refer to the Coordinates menu)

Next the radius of the desired circle should be entered by inputting the coordinates.

The centre of the circle and the point on the circumference of the circle are saved as points of construction.

Item	Description
1	Centre of the circle
2	Point on the circumference of the circle

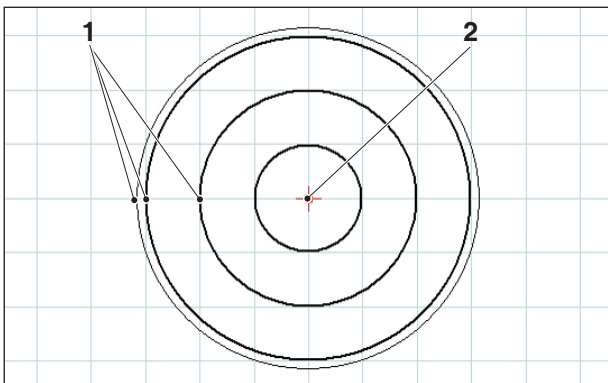

Concentric circles

Concentric circles

After the input of the circle center you have to define a point at the circumference of the required circle. The circle will be immediately drawn by means of the mouse movement. To create additional concentric circles, you only have to enter the circle points.

The circle center and the circle points will be saved as design points.

Item	Description
1	Points on the circumference of the circle
2	Centre of the circle

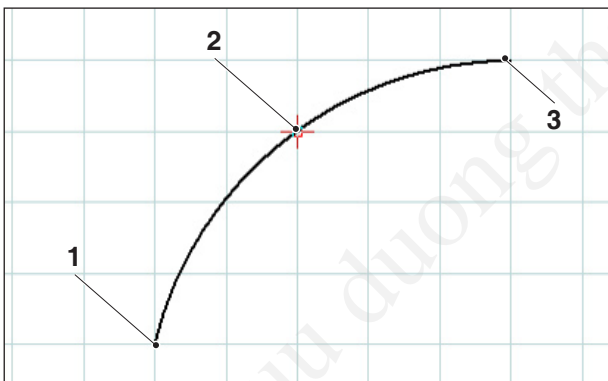

Circular arc with starting, target and circle point

Circular arc with starting point, target point and circle point

After having selected the symbol, you have to define the starting point of the circular arc, then the target point and finally, a point on the circular arc. The circle will be immediately drawn by means of the mouse movement.

The starting point, the target point and the center point will be saved as design points.

Item	Description
1	Starting point
2	Point on the circumference of the circle
3	End point

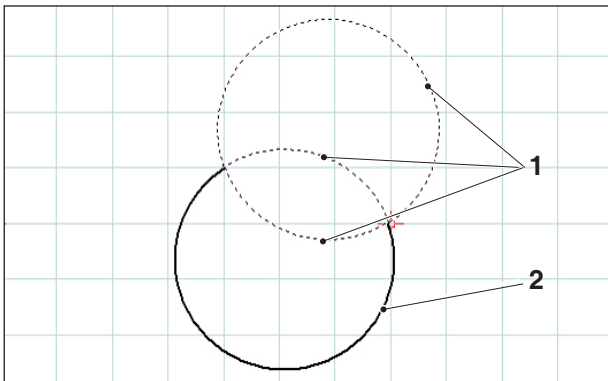

Circular arc with starting point, target point and radius

Circular arc with starting point, target point and radius

After having selected the symbol, you have to define the starting point of the circular arc, then the target point and finally, the radius of the circular arc.

From these inputs result 2 possible circles with 2 possible circular arcs each. The circular arc selected is displayed as a full line, the possible circular arcs as dashed lines. Use the left mouse button to select a possibility.

The starting point, the target point and the center will be saved as design points

Item	Description
1	Possible arcs
2	Selected arc

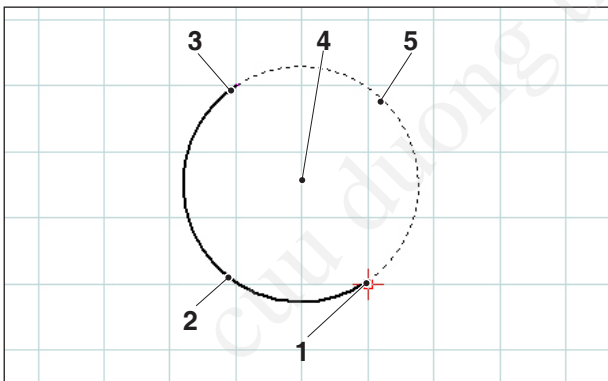

Circular arc with starting point, target point and circle center

Circular arc with starting point, target point and center

After having selected the symbol, you have to enter the starting point of the circular arc, then the target point and finally, the center of the circular arc.

From these inputs result 2 possible circular arcs. The circular arc selected is displayed as a full line, the possible circular arc as a dashed line. Use the left mouse button to choose a possibility.

The starting point, the target point and the center will be saved as design points.

Item	Description
1	Starting point
2	Selected arc
3	End point
4	Centre
5	Possible arc



Insert radius

After having selected the symbol, you have to choose the lines of the corner to be rounded. The selected elements change their colour. Then you have to enter the radius of the chamfer.

The end points and the center of the circular arc will be saved as design points.

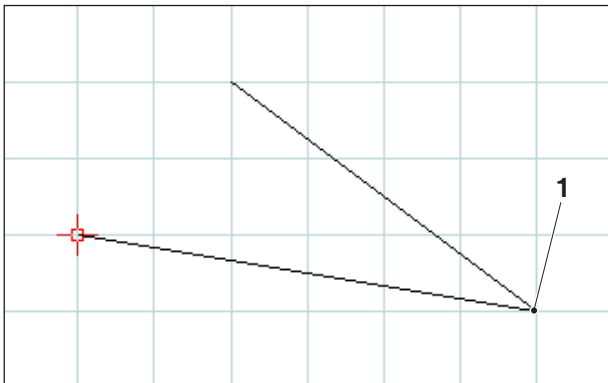

Corner point to be rounded

Item	Description
1	Corner point to be rounded off
2	Arc end points
3	Arc centre

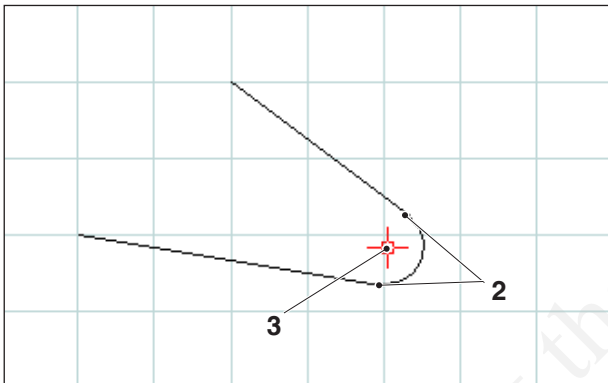

Radius inserted

CuuDuongThanCong.com

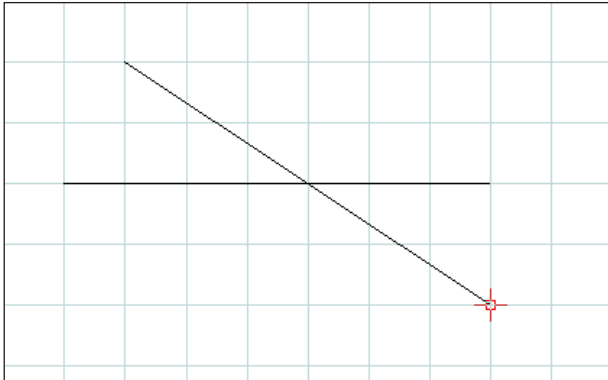

Selection of the elements to be rounded off

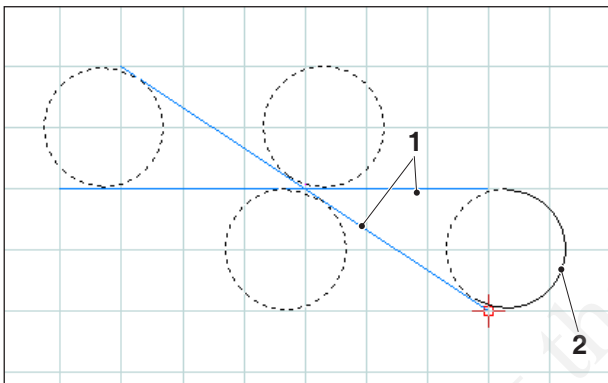

Selection of the possible arcs

Rounding off elements

Example of line-to-line rounding

After selecting the symbol, the elements which are to be rounded off should be selected, and after this the radius of the arc.

This information results in 4 possible circles, each with 2 possible arcs. The selected arc is shown as a continuous line, the possible arcs as dotted lines. Left-click with the mouse to choose one of the options.

The starting point, end point and centre are saved as points of construction.

Item	Description
1	Elements which are to be rounded off
2	Selected arc

Example: Rounding of line and circle

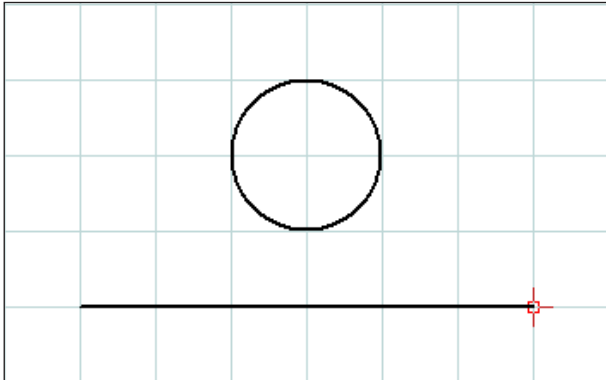

Selection of the elements to be rounded

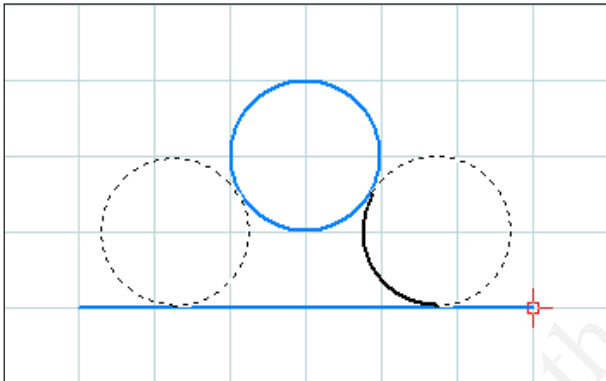

Possible circular arcs

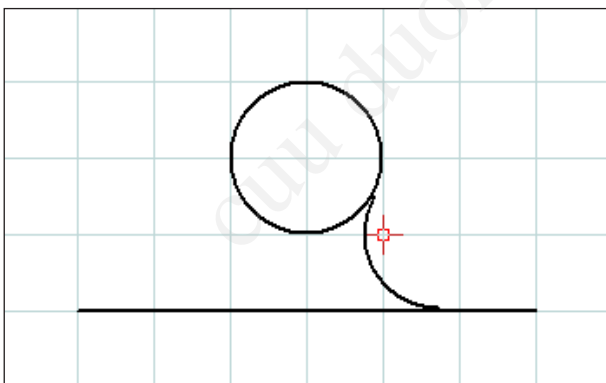

Rounded line and circle

Example: Rounding of circle and circle

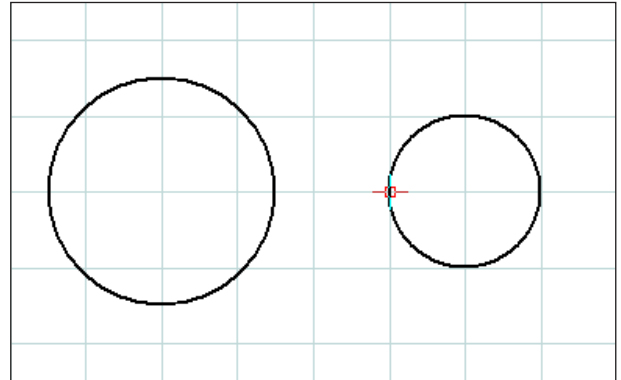

Selection of the elements to be rounded

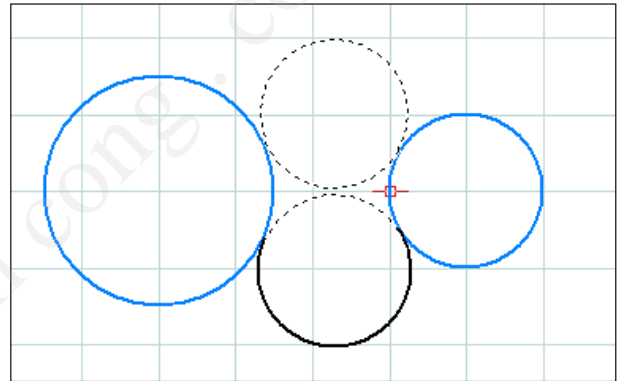

Possible circular arcs

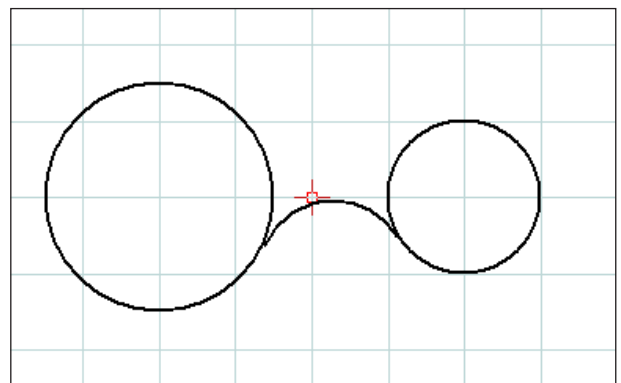

Rounded circle and circle



Text menu

After selecting the icon, 3 icons appear for creating texts.



Created text



Text at point



Text on line



Text on arc

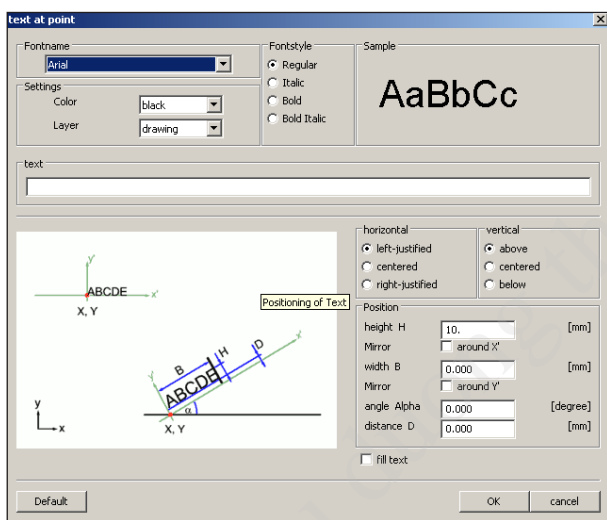

Text input window

After selecting the required text icon the text input window appears:

- **Font name:** you can select your preferred font via the dropdown menu. All of the TTF fonts installed in the system are available.
- **Properties:** Select the colour and/or layer of the text you wish to create.
- **Font style:** Here you can change the style of the text you wish to create.
- **Sample text:** This shows a preview of your chosen font settings.
- **Text:** Enter the required text here.

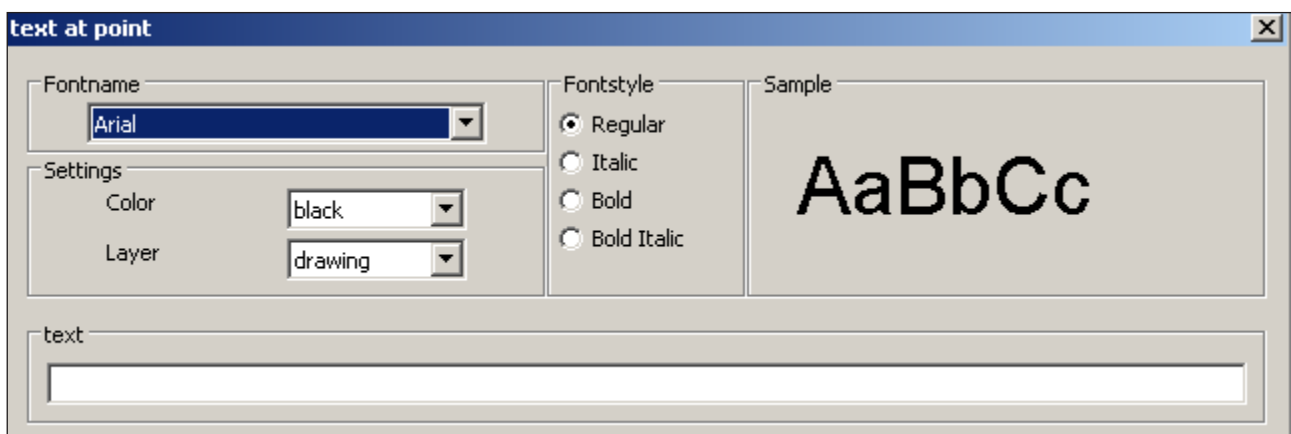

Text input window - font settings

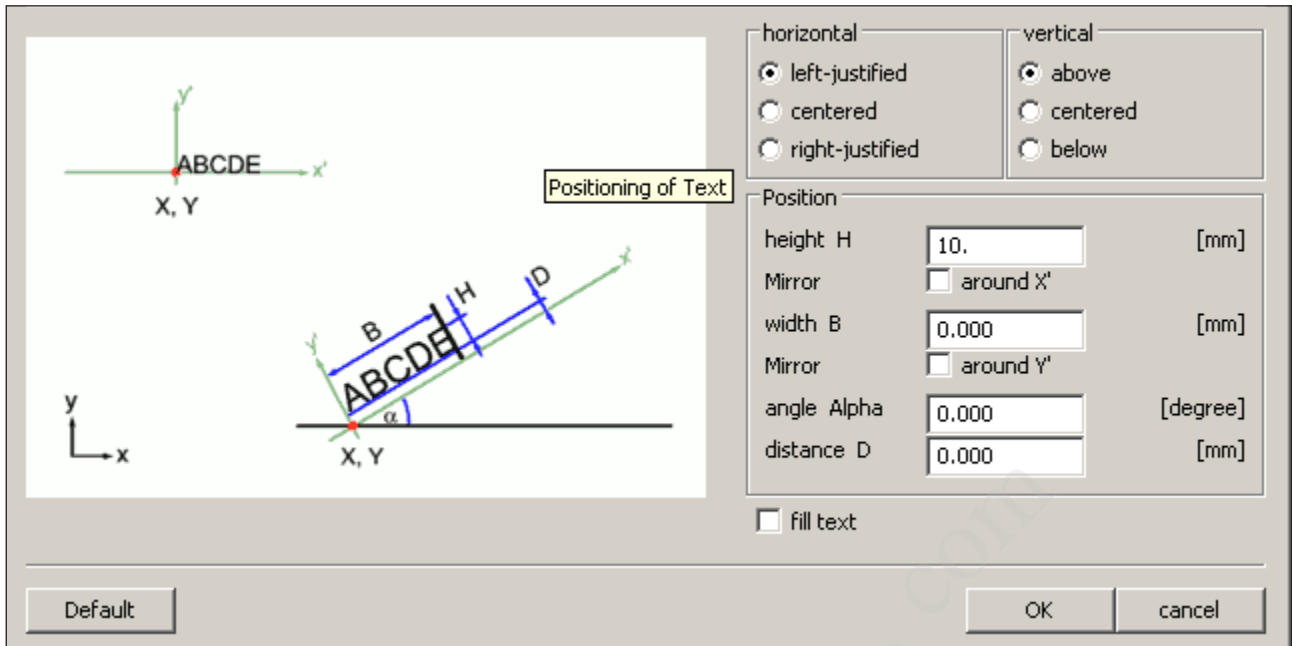

Text input window - adjusting the position of the text

- Horizontal: Here you can select the horizontal alignment of the text you wish to create (left-justified/centred/right-justified).
- Vertical: Here you can select the vertical alignment of the text you wish to create (above/centred/below).
- Fill text: Select this option to display the text filled.

• Position:

Height H / width B: The specified font is scaled to the selected height / width. The default value "0" means that no scaling is applied.

Mirror around X' / Y': When this option is selected the text is mirrored around the X' / Y' axis.

Angle Alpha: Enter an angle for the gradient of the text.

Distance D: Specify a distance D to the reference point (point, line or arc).

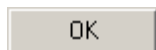

Click on "OK" to confirm your selections. Then define the point, line or arc for text positioning.

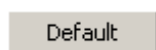

If you click on the "Default" button the settings you have selected will be discarded and the default settings restored.

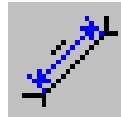

Dimensioning menu

After having selected the symbol, 6 symbols for dimensioning will appear:

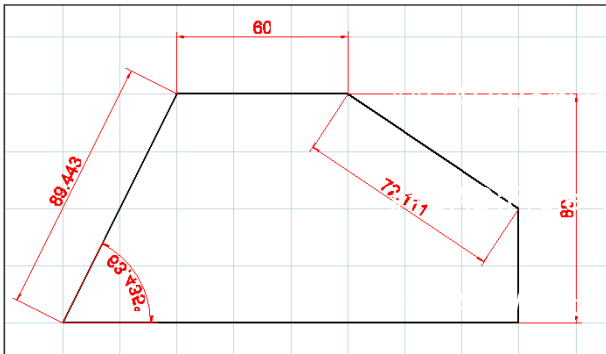

Dimensioning examples



horizontal dimensioning



vertical dimensioning



free dimensioning



dimensioning of angles



dimensioning of diameter



dimensioning of radius

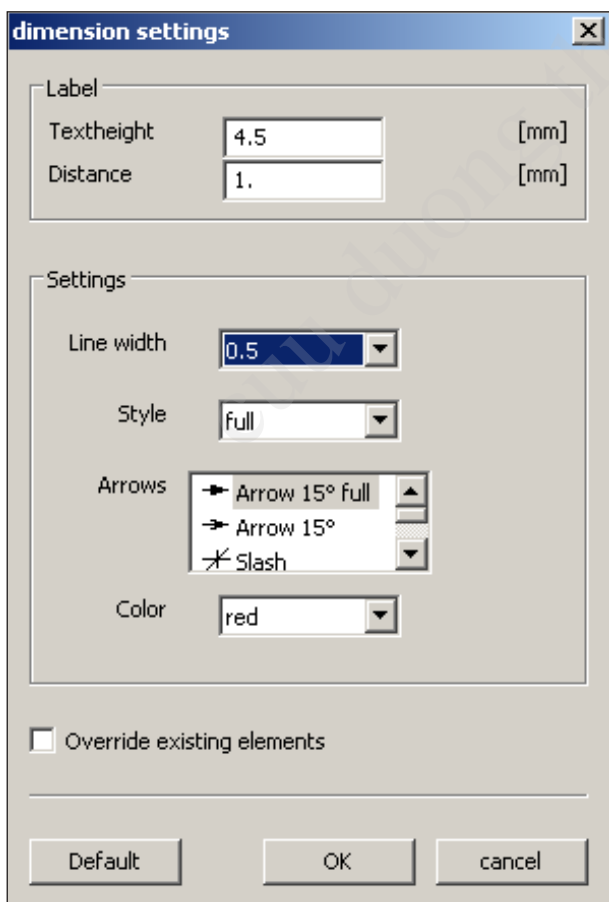

Dimension settings

After having selected the required dimensioning symbol, please define the dimensioning points. You can increase or reduce the distance of the dimensioning to the drawing element by dragging the mouse.



Dimension settings

- **Labelling**
Enter the size of the dimension text. Alternatively, you can also specify the distance between the dimension text and the dimension line.
- **Settings**
Define the line width and style. Choose the required dimension arrows and the colour for the dimension.
- **Override existing elements**
This option is used if you wish to apply the latest settings to existing dimensions.

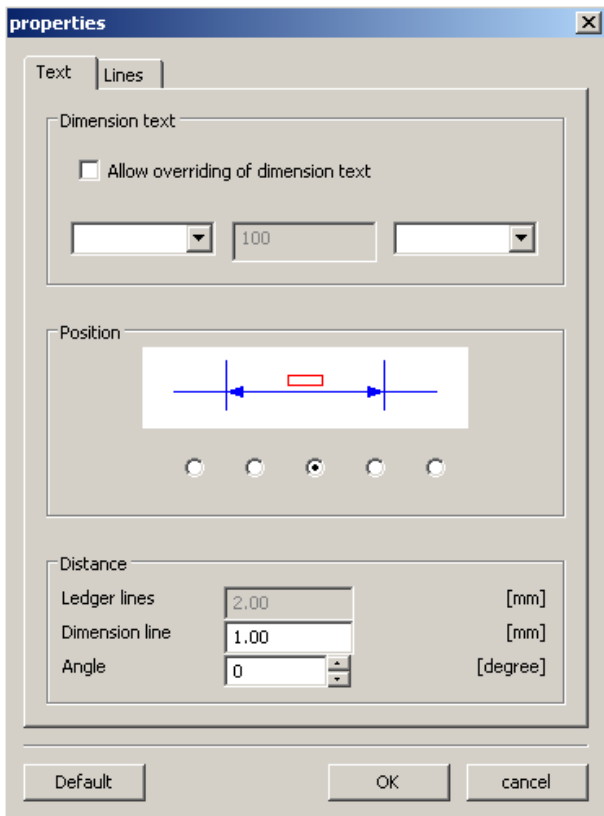

Properties window - text

Properties window - dimensioning

Note:

With the key combination CTRL + right-hand mouse button you can call up the properties window for dimensioning and retrospectively change the dimensioning properties.

In the "Text" tab you can change the following properties:

- Dimension text
You can overwrite the dimension value and specify a text which appears before or after the dimension text.
- Position
You can change the position of the dimension text.
- Distance
You can change the distance to the dimension line or ledger lines and the angle between the dimension text and the dimension line.

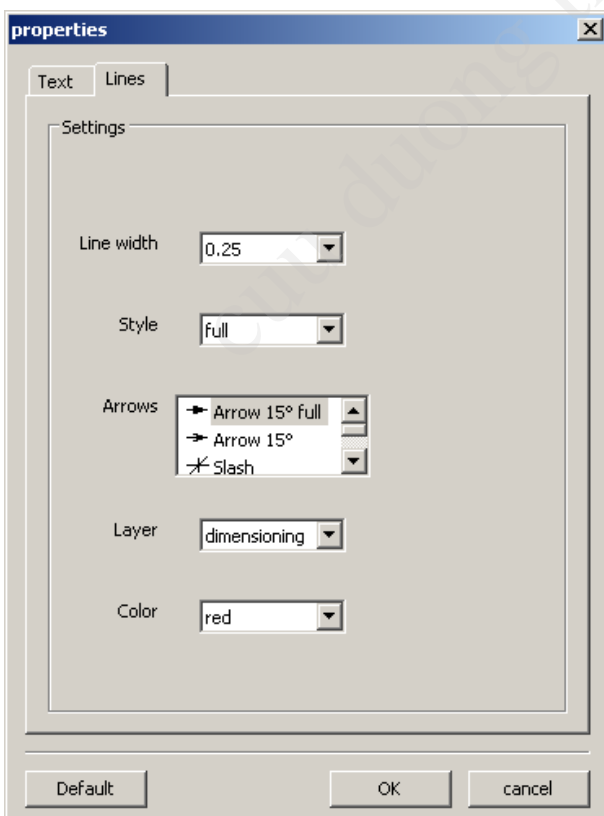

Properties window - text

In the "Lines" tab you can change the following dimension properties:

- Line width
- Line style
- Dimension arrows
- Layer
- Colour

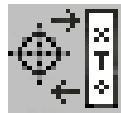

Symbol menu

After having selected the symbol, the window for symbol administration will appear. Symbols serve to reducing the drawing process of already pre-defined and stored drawing objects. These drawing objects are saved as symbols within categories.

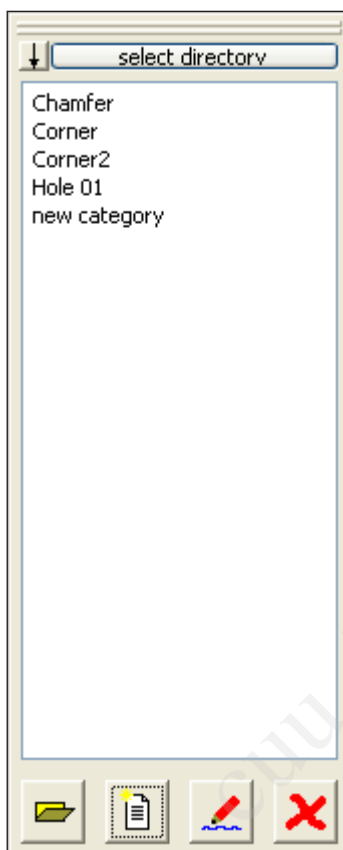

*Symbol administration
Summary of the categories
of the CAMConcept direc-
tory*

Creating categories

Press "Select directory" in order to save new categories in a basic directory that is different from the one proposed by CAMConcept.



These icons can be used to change the sorting order.



Open category

Select the required category and open it by means of the icon or a double click with the left mouse button.



New category

Create a new category. Then rename this "New category".



Rename category

Select the required category and rename the text field by means of the icon or a mouse click.



Delete category

Select the required category and delete it by means of the the icon or the key "Delete".

Creating symbols



Select the required category and open it by means of the icon or a double click with the left mouse button. Now the window of the symbol administration displays all symbols of the respective category with graphic and name.



These icons enable to display the inputs either with or without graphics.



Insert symbol in drawing

Select the required symbol and drag it into the drawing by means of the icon or the mouse. Move the point of contact to the desired position in the drawing and press the left mouse button.



Create new symbol

After having selected the icon, use the mouse to draw a selection rectangle around the required elements and press the left mouse button. The selected elements change their colour. Select the point of contact where the symbol is orientated when used in the CAD window.



Symbol properties

This icon enables to rename already defined symbols. Select the required symbol and rename the text field by means of the icon or the right mouse button. You can enter the symbol name and additional descriptions.



Delete selected symbol

Select the required symbol and delete it with the icon.

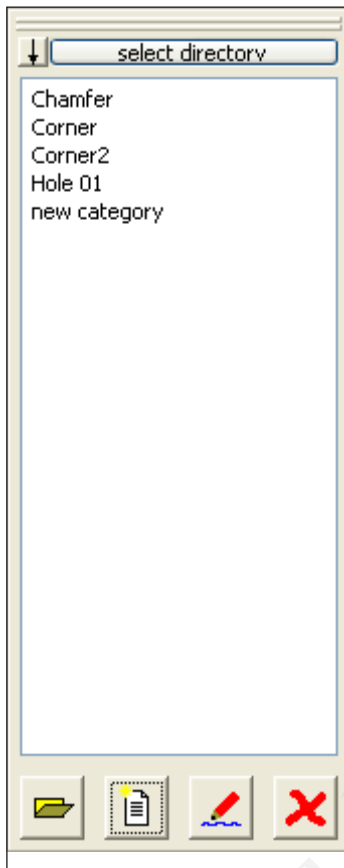

*Symbol administration:
Summary of the symbols of
a category*

Change menu



Selecting an element

After selecting the icon you can choose one or more in order to subsequently change them; e.g. delete, rotate, shift.

An element can be selected by:

- clicking on the required element.
- dragging the selection rectangle over the required selection range (keep the left-hand mouse button pressed while doing this). This will only include elements which are fully within the selection rectangle.
- When selecting individual elements or dragging the mouse pointer, the element positioned closest to the mouse pointer is highlighted with a different colour in order to indicate the relevant candidate (for selection). The elements which have already been selected are highlighted with another (different) colour.

Ctrl

To make a multiple selection, press and hold the button while selecting elements or areas. You can also deselect an already selected element by selecting it again.



Cutting an element

After having selected the symbol, you have to select the element that should be cut. The selected element changes its colour.

Then you have to choose the cutting point.

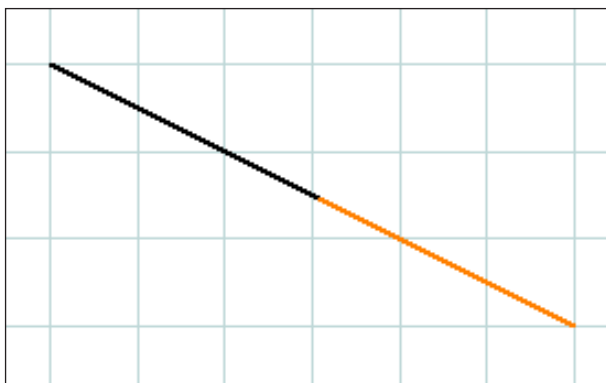

Line cut at the center of the line

Item	Description
1	Line centre



Trimming 1 element

After having selected the symbol, you have to choose the element to be trimmed. Then you have to select the second element. You can either shorten or lengthen elements.

Item	Description
1	Element which is to be trimmed
2	2. Element

Example: Shorten line by means of trimming

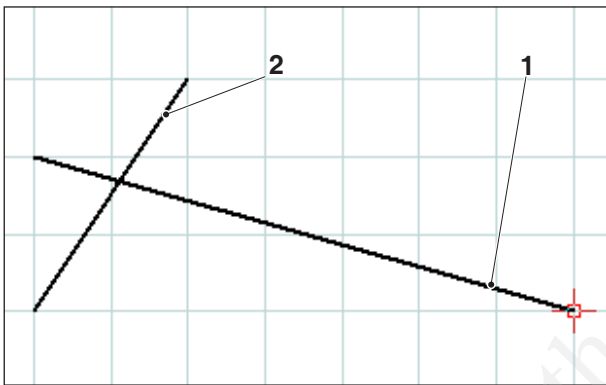

Selection of the line to be shortened

Example: Lengthen line by means of trimming

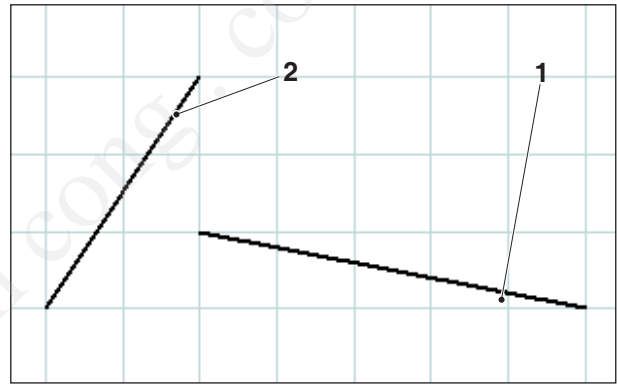

Selection of the line to be lengthened

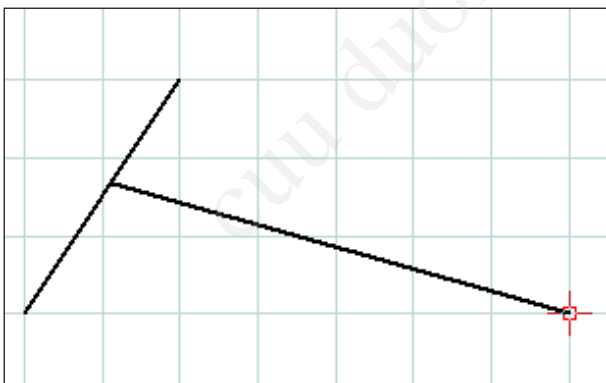

Ready trimmed line

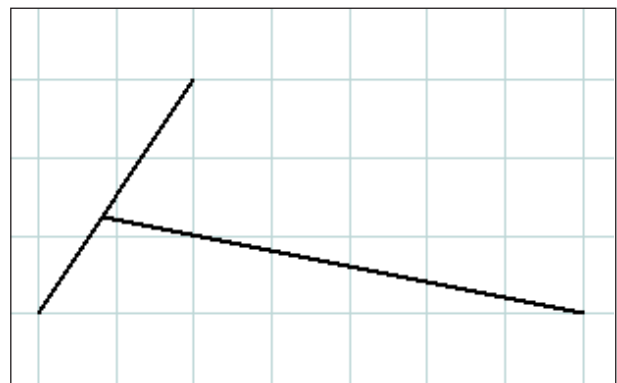

Ready trimmed line



Trimming with 2 elements

Example: Trim line with circle

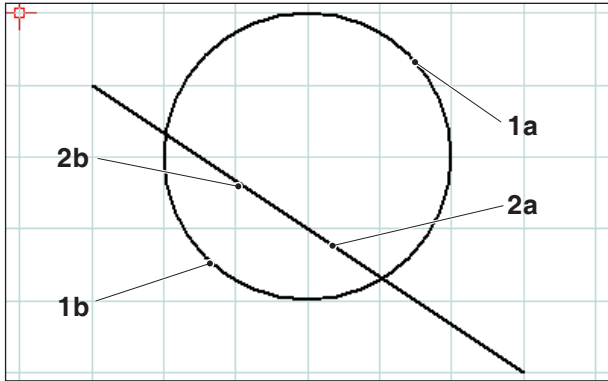

Selection of the elements to be trimmed

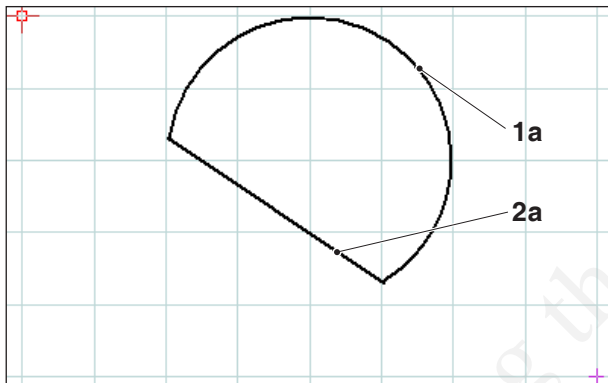

Finished trimmed elements - selection 1a and 2a

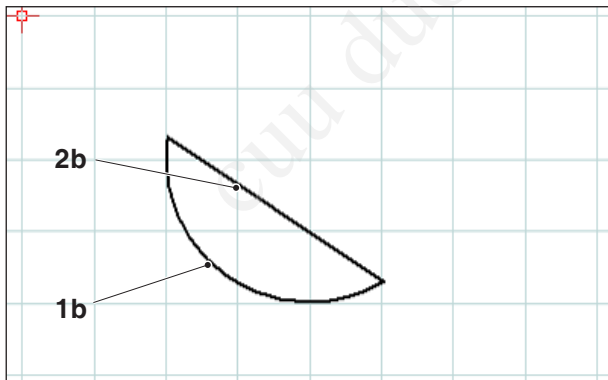

Finished trimmed elements - selection 1b and 2b

After clicking on the icon, select the elements you wish to trim. Elements can be shortened or lengthened (refer to the example "Trimming 1 element").

As this function can produce several possible outcomes, such as

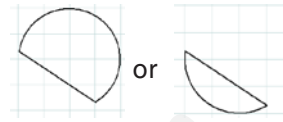

the outcome will depend on the position of the mouse when the first or second element is selected.

Item	Description
1a, 2b	Elements to be trimmed
2a, 2b	Elements to be trimmed
3	Point of intersection
4	New end point = point of intersection

Example: Trimming a line with a line

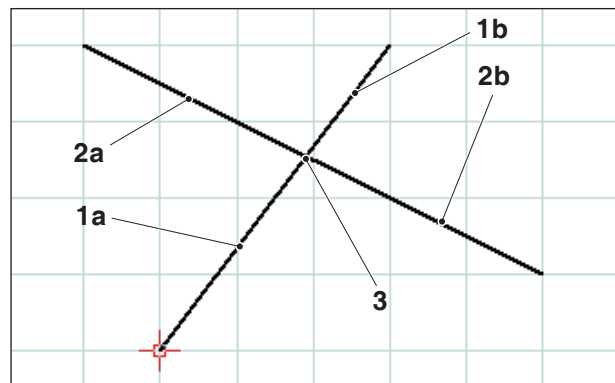

Select of the lines to be trimmed

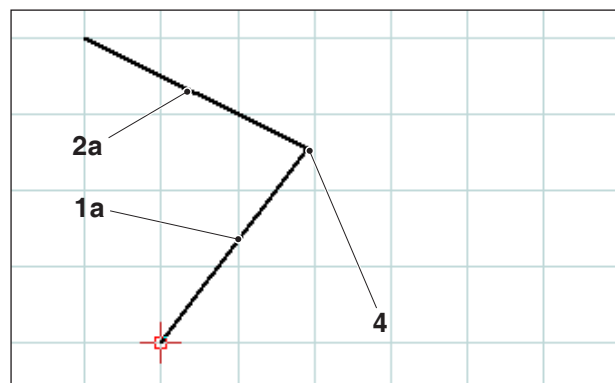

Finished trimmed lines - selection 1a and 2a



Creating hatching

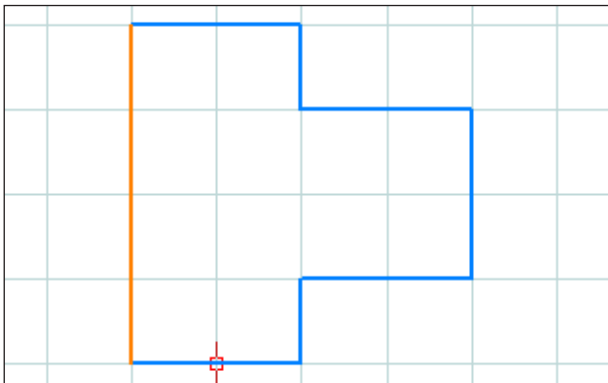

Selection of the outline

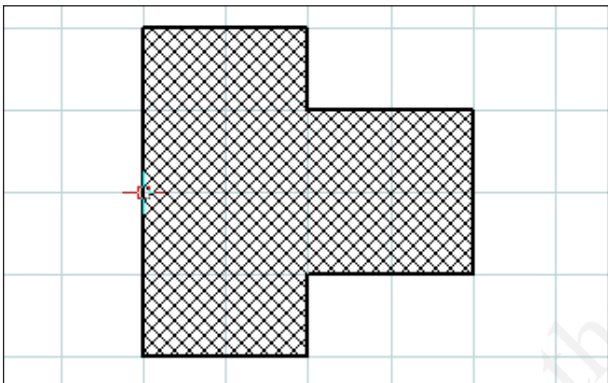

Hatching inside the selected outline

After clicking on the icon, select the outline you wish to fill with hatching. Left-click on the elements to select them. As soon as the outline is closed the enclosed area is filled with hatching.

Hatching properties window

Note:

With the key combination CTRL + right-hand mouse button you can call up the properties window for dimensioning and retrospectively change the dimensioning properties.



In the "Hatching type" tab you can choose your preferred type of hatching. The "Formatting" tab allows you to change the colour of the hatching.

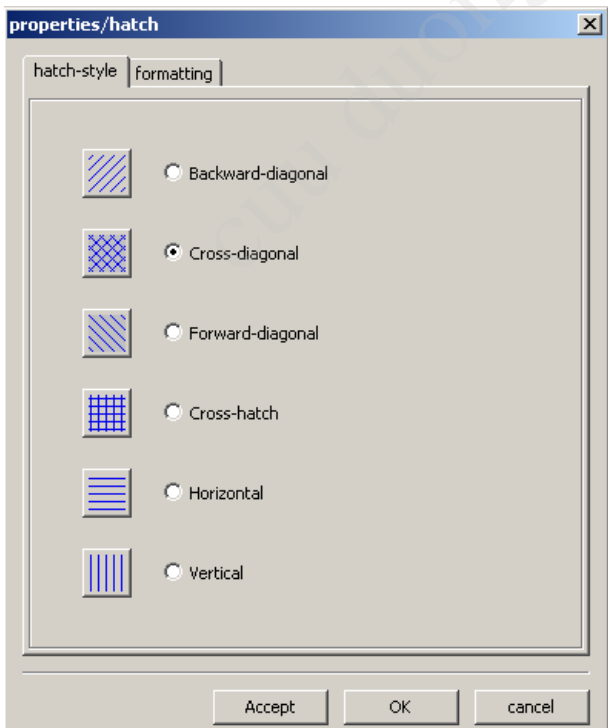

Properties window - hatching

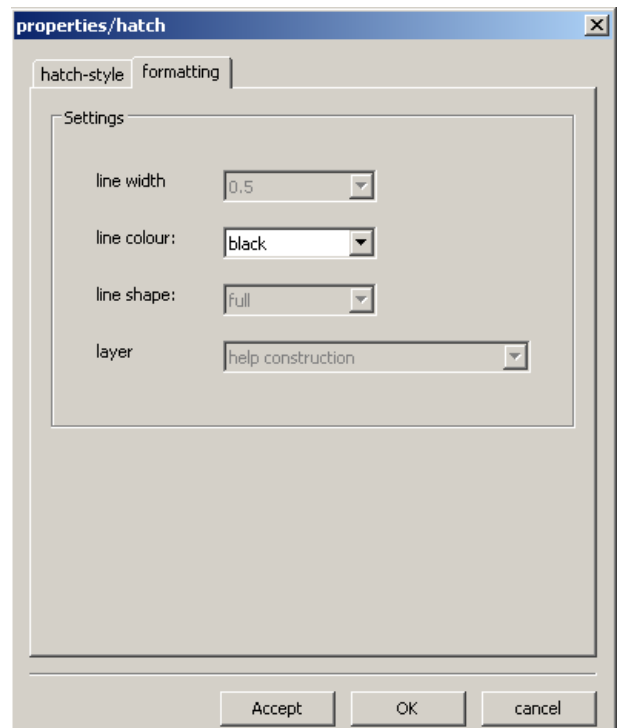

Properties window - hatching



Delete

After selecting the elements you wish to delete, click on the "Delete" icon.

The selected elements are deleted when you click on the icon.



Shifting an element absolutely or incrementally

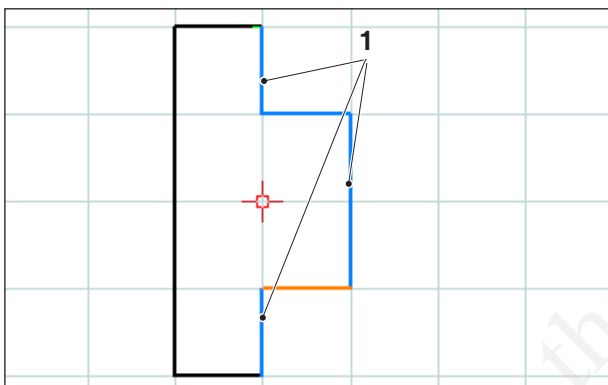

Selection of the elements

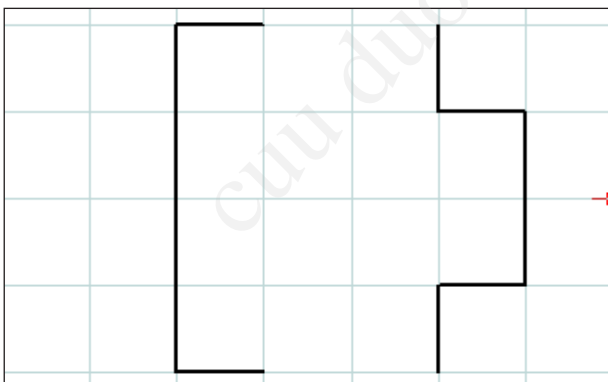

Selection of the elements

After selecting the elements you wish to shift, you can click on the icon for "Shifting an element absolutely or incrementally".

After clicking on the icon you can input the following:

- Input the incremental shift in the input field for the axes.

or

- Left-click with the mouse on a reference point and select an end point for the absolute shift.

The shift relates to the position of the selected elements.

Item	Description
1	Selected elements



Shifting and copying an element absolutely or incrementally

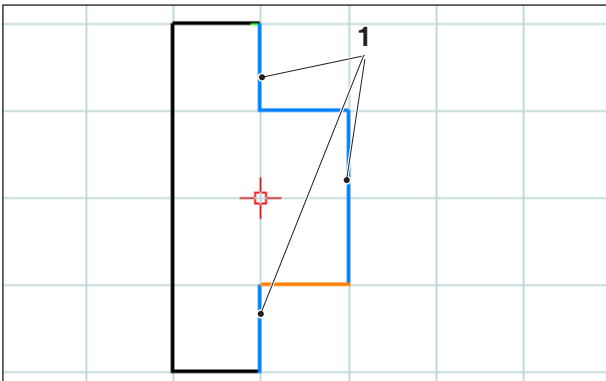

Selection of the elements

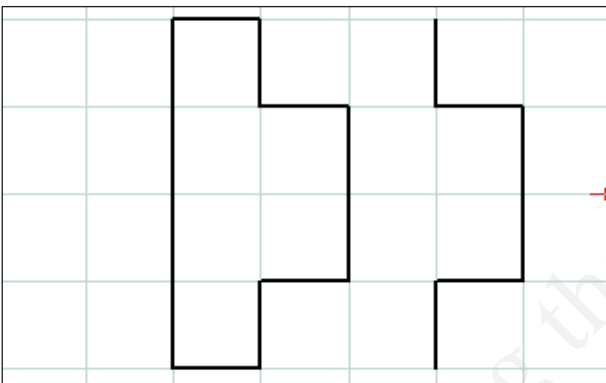

Shifted and copied elements (1 copies)

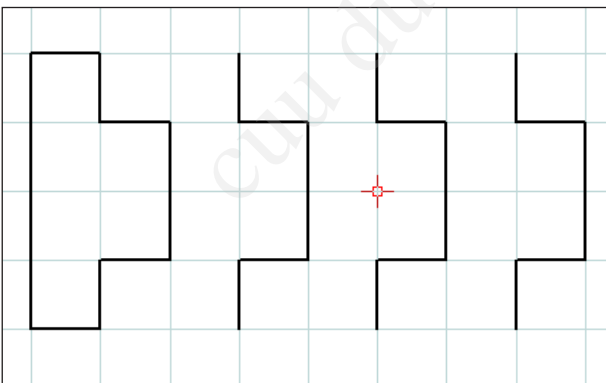

Shifted and copied elements (3 copies)

After selecting the elements you wish to shift, you can click on the icon for "Shifting and copying an element absolutely or incrementally".

After clicking on the icon you can input the following:

- Input the incremental shift in the input field for the axes.

or

- Left-click with the mouse on a reference point and select an end point for the absolute shift.

The shift relates to the position of the selected elements.

Afterwards enter the required number of copies in the input field.

Item	Description
1	Selected elements



Rotate

After selecting the elements you wish to rotate you can click on the "Rotate" icon.

After clicking on the symbol, select the point of rotation by entering its coordinates in the input field or by left-clicking with the mouse. The point of rotation is the point around which the elements are rotated.

Enter the angle of rotation in the input field. A positive or negative value can be entered for the angle of rotation.

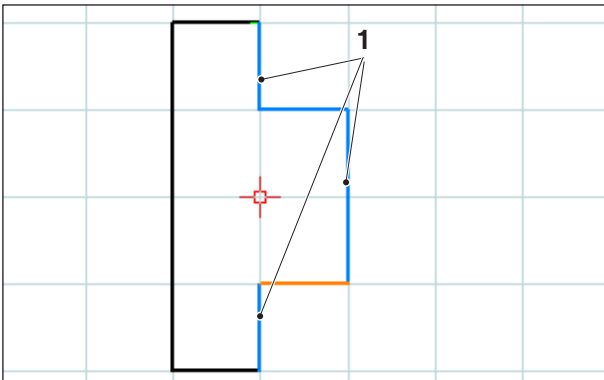

Selection of the elements

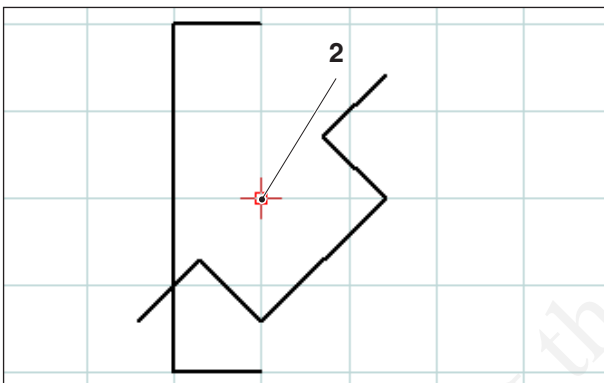

Rotated elements (-45°)

Item	Description
1	Selected elements
2	Point of rotation



Rotating and copying

After selecting the elements you wish to rotate you can click on the "Rotate and copy" icon.

After clicking on the symbol, select the point of rotation by entering its coordinates in the input field or by left-clicking with the mouse. The point of rotation is the point around which the elements are rotated.

Enter the angle of rotation in the input field. A positive or negative value can be entered for the angle of rotation. With multiple copies, the angle always relates to the position of the previous copy.

Enter the required number of copies in the input field.

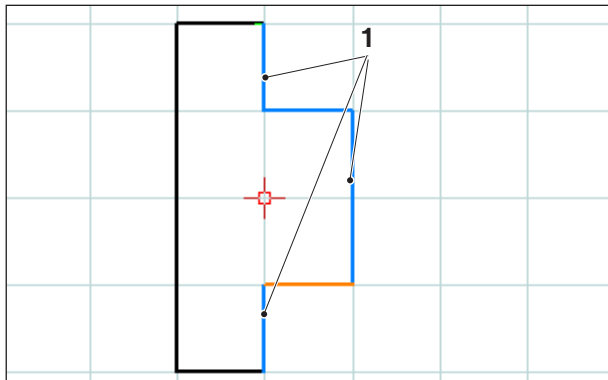

Selection of the elements

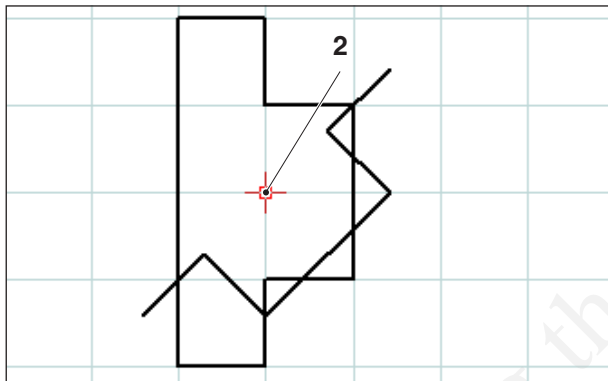

Rotated and copied elements (-45°; 1 copies)

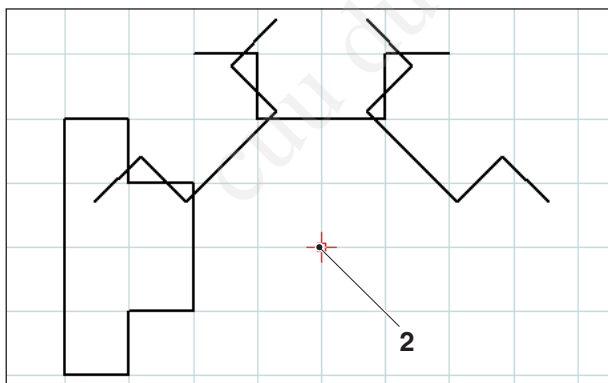

Rotated and copied elements (-45°; 3 copies)

Item	Description
1	Selected elements
2	Point of rotation



Mirroring

After selecting the elements you wish to mirror you can click on the "Mirroring" icon.

Once you have clicked on the icon you can define the mirror axis. The mirroring is defined by the first and second points entered for the mirror axis. By entering these points you can freely define mirror axes as required.

Select the first and second point of the mirror axis by entering the coordinates or by left-clicking with the mouse.

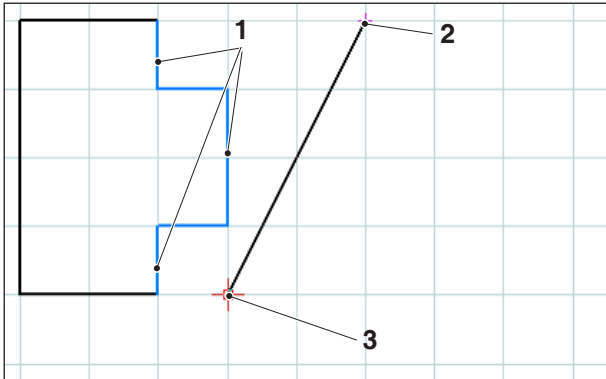

Selection of the elements; mirror axis

Item	Description
1	Selected elements
2	1. point on the mirror axis
3	2. point on the mirror axis

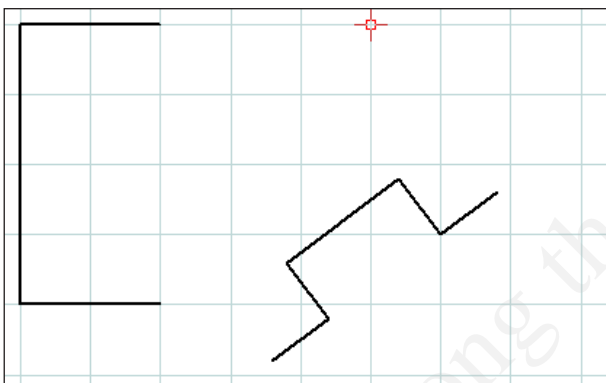

Mirrored elements



Mirroring and copying

After selecting the elements you wish to mirror you can click on the "Mirror and copy" icon.

Once you have clicked on the icon you can define the mirror axis. The mirroring is defined by the first and second points entered for the mirror axis. By entering these points you can freely define mirror axes as required.

Select the first and second point of the mirror axis by entering the coordinates or by left-clicking with the mouse.

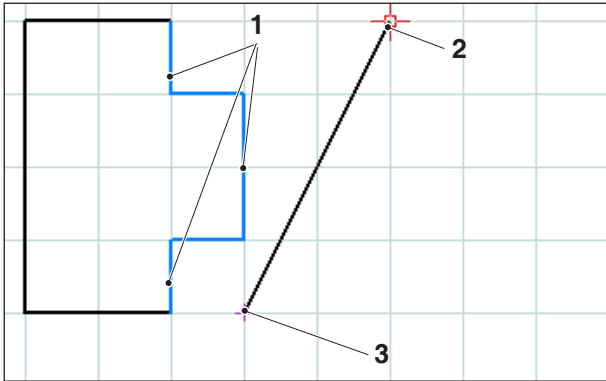

Selection of the elements; mirror axis

Item	Description
1	Selected elements
2	1. point on the mirror axis
3	2. point on the mirror axis
4	Selected elements
5	Mirrored and copied elements

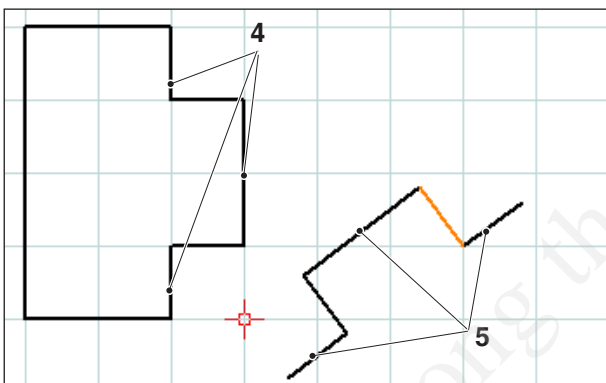

Mirrored and copied elements



Scaling

The term 'scaling' means making elements smaller or larger.

After selecting the elements you wish to scale you can click on the "Scaling" icon.

Scaling is defined by entering a scaling point and the scaling factor. The scaling point is the centre of the scaling.

Select the scaling point and the scaling factor in the input field.

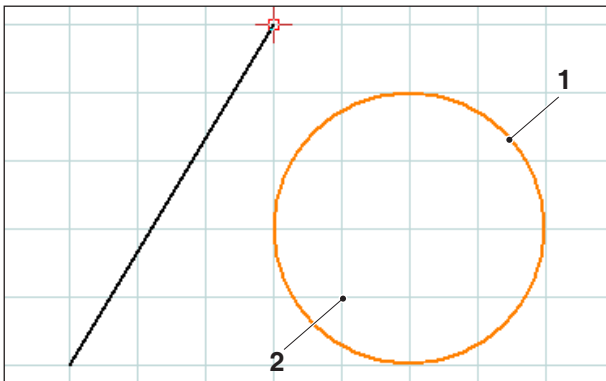

Selection of the elements; scaling point

Item	Description
1	Selected element
2	Scaling point

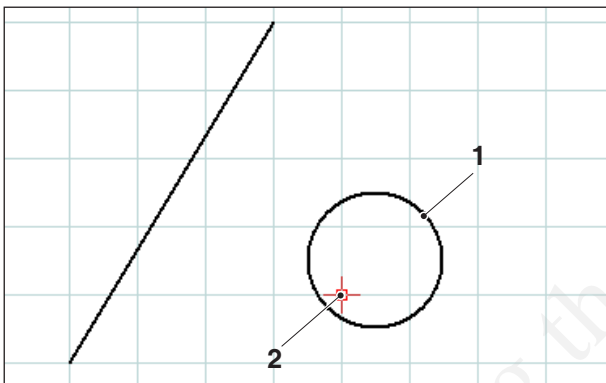

Scaled element, here: Scaling factor = 0.5

cuu duong than cong . com

E: CAM commands



CAM mode

The CAM command symbols are activated by clicking on the shift symbol "CAM". The CAM mode will remain active until it is deactivated again by means of CAD, NC or AV (operations scheduling).

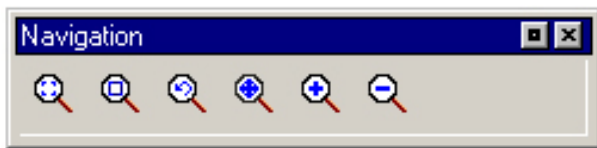

The zoom commands are explained in chapter B.



Restructuring

After pressing the F5 key the screen is restructured again.

After delete and modifying functions it may happen that lines are not completely displayed on the screen. In this case use the function "Restructure" or the zoom commands to get a new display of the screen.



Generating



Settings

The settings serve to defining the machine type. Tools can be entered from an extensive tool database into tool tables. Measurements of unmachined parts are defined by means of an input graphic.

Note:

Additional new tools for the tool database can be created easily and quickly by means of the "3D ToolGenerator".



Machine

After having selected the symbol, you can choose the machine type (only at programming places) and the corresponding tool tables. The tool tables are saved in the respective project file (*.ecc). The active tool table can be saved under a freely selectable name at any time, so as to be available for other projects as well.

You can define the tool changing point by means of the coordinates X and Z. The coordinates of the tool changing point are referred to the machine zero point. Prior to the tool change, this position will be traversed with the slide reference point.

The tool changing point has to be defined in such a way, that there will be no collisions during the tool change.

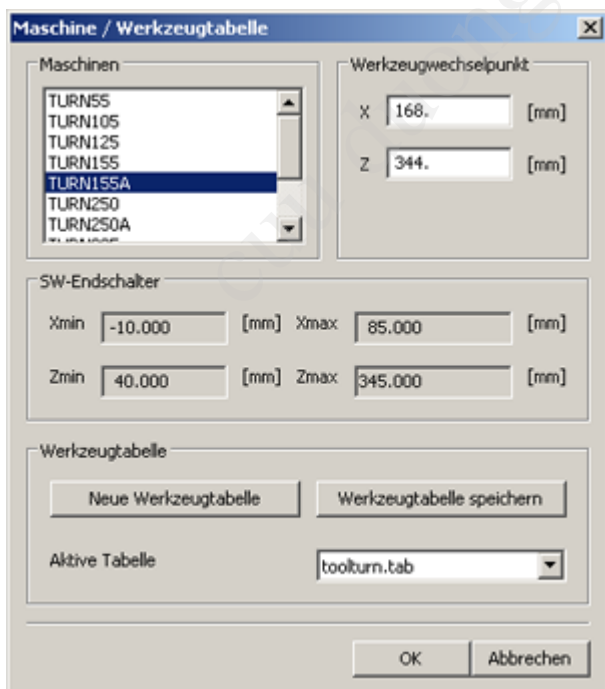



Tool measurement

tool measurement

tool name

X 148.000 F 0.00
Z 334.000 S 0
T 0 D 1

acttool.tab >>

T.D	TOOLNAME
1.1	Schlichtstahl SDNC N 12
1.2	Gewindestahl NL12-3 R
1.3	Schruppstahl SCAC L 121
2.1	Schlichtstahl SVJC R 12
2.2	Schlichtstahl SDJC L 12
3.1	

[END]

T 1 D 1

Xm 0.000 Zm 0.000

tool offsets

X 0.000 Z 0.000
I 0.000 K 0.000

Insert edge F1, Reset tool F2, Change name F3, Tool database F4, Geometry F5, Technology F6, Tool edge F7, Back F8

After having selected the symbol, the CAMConcept window "Tool measurement" will appear. Now you can edit the tool system of the NC machine:

- Define a new tool with the "3DView tool generator" and add it to the tool library.
- Delete an existing tool.
- Measure the tool at the machine.
- Insert a new tool or cut into the tool table

tool measurement

X 82.000 F 0.00
Z 81.000 S 0
T 0 D 1

toolturn.tab

T.D	TOOLNAME
1.1	Schruppstahl SCAC L 121
2.1	Gewindestahl NL12-3 L
3.1	Schlichtstahl SDJC L 16

[END]

T D

Insert tool, Tool database, Back

Enter new tool place

- Move the cursor to [END].
- Press the softkey "Insert tool F1".
- Define all tool geometry and tool technology data.

Move cursor to [END].

tool measurement

tool name

X 82.000 F 0.00
Z 81.000 S 0
T 0 D 1

toolturn.tab >>

T.D	TOOLNAME
1.1	Schruppstahl SCAC L 121
2.1	Gewindestahl NL12-3 L
2.2	Gewindestahl NL12-3 L
3.1	Schlichtstahl SDJC L 16

[END]

T 2 D 2

Xm 0.000 Zm 0.000

tool offsets

X 0.000 Z 0.000
I 0.000 K 0.000

Insert edge, Delete tool, Change name, Tool database, Geometry, Technology, Tool edge, Back

Enter a new place for additional tool blade

- Move the cursor to the tool number to which an additional tool blade shall be entered.
- Press the softkey "Insert edge F1". A additional tool blade will be added to the existing tool number.

Enter additional tool blade.

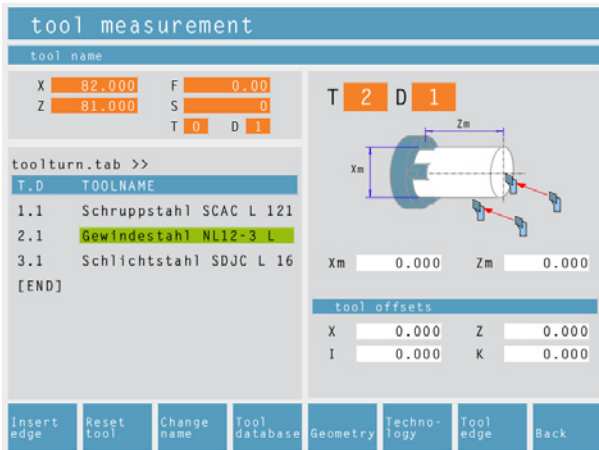

Delete existing tool.

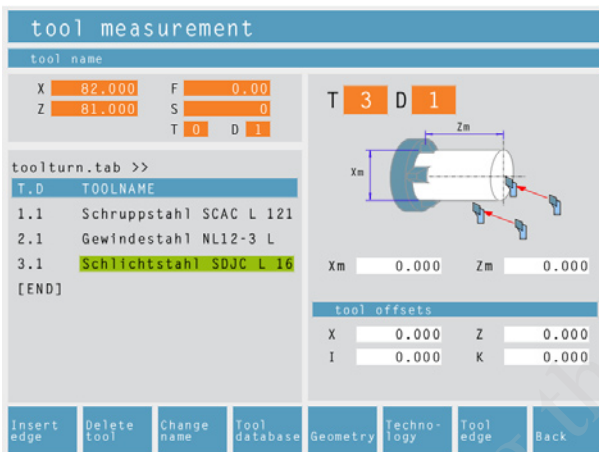

Delete tool place.

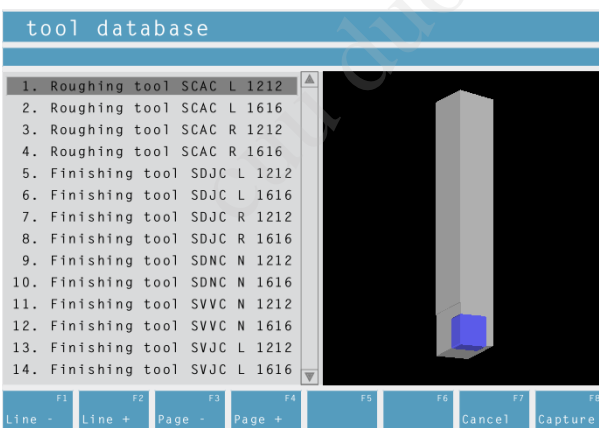

Tool database

Delete existing tool

- Move the cursor to the tool to be deleted.
- Press the softkey "Reset tool F2". The tool place will be emptied, but preserved.

Delete tool place

- Move the cursor to the tool with the highest T number (last tool on the list).
- Press the softkey "Delete tool F2". The whole tool place will be deleted.

Entering a tool from the tool database into the tool table

- Press the soft key "Tool database F4".
- Move the cursor keys to the tool you wish to capture.
- Press the soft key "Capture F8".
- The required tool will be entered into the tool table at the chosen position.
A previous tool, if existing, will be replaced by the new one.

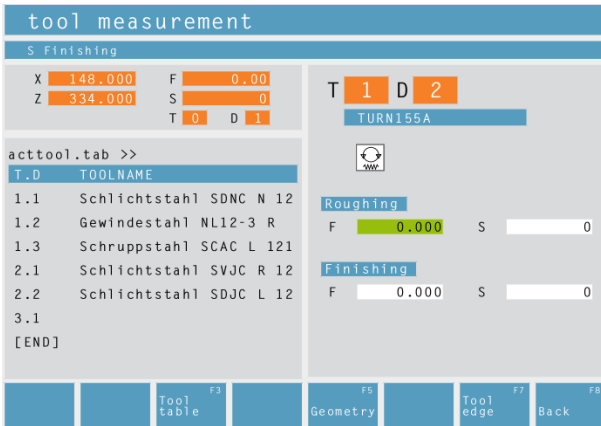

Technology data for tools

Defining tool data

- Fasten a workpiece of known height in the toolholder.
- Press the soft key "Change tool F3".
- Define the following parameters:
 - Zm...Z-coordinate of the calibration part
 - Xm...X-coordinate of the calibration part
 - X...tool length in X
 - I...wear in X
 - Z...tool length in Z
 - K...wear in Z

The standard values of the machine for the feed and for the spindle speed can be further limited by means of the soft key "Technology F6". After selection of the tool the respective spindle speeds and feeds will be already entered in the cycles as changeable proposal.

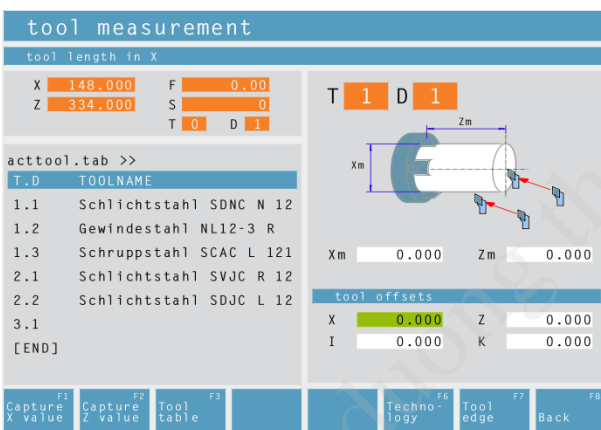

Tool database

Tool family / Tool edge position

Use the soft key "Tool edge F7" to select the tool shapes and tool edge positions that are provided by CamConcept.

The following families are not possible:



- Indexable insert, rhombic
- Thread cutting insert
- Plunge-cutting insert
- Indexable insert, round
- Drill or driven tool



Note:

In order to determine the type, look at the tool

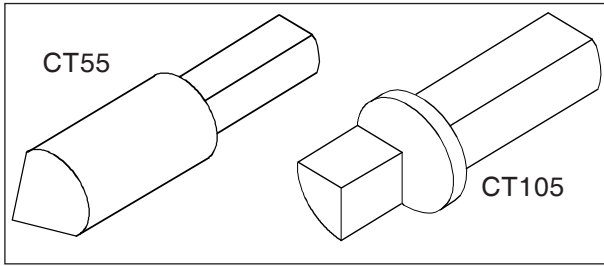

Reference tool Concept Turn 55 / 105

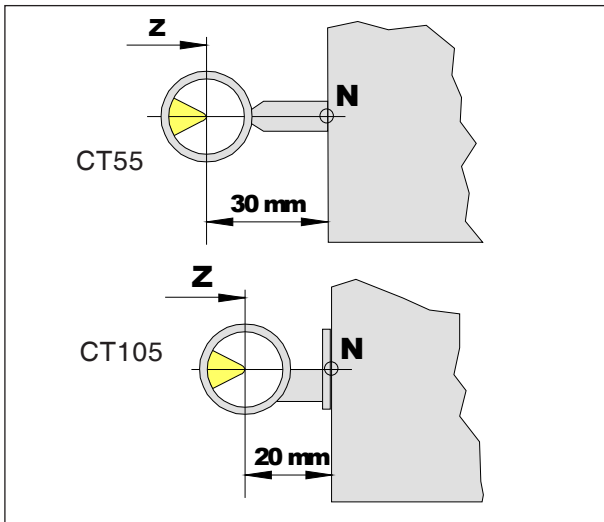

Calibration of the reference tool

Tool measuring with optical pre-setting device

1.) Calibration of optical pre-setting device:

- Set up optical pre-setting device.
- Tighten reference tool with tool holder into the tool turning table.
- Call up the tool table and select the reference tool place.
- Insert reference tool as a drilling or milling cutter.
- Swing out the reference tool with and run the tool spike into the cross hair.
- Calculate the position value of the Z axis, as displayed, reduced by 30 mm (20 mm).

Geometry

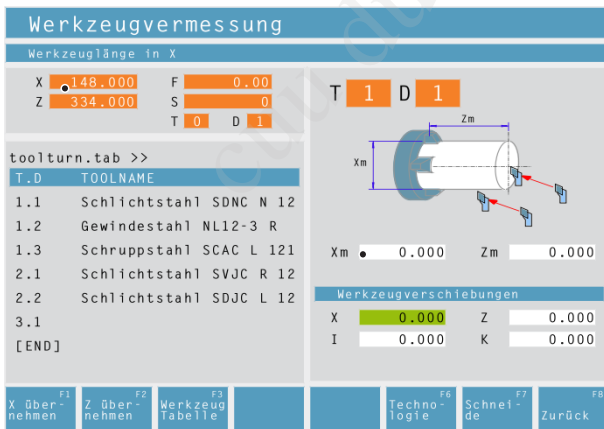

- Enter Xm= (position value of X axis displayed) and Zm= (calculated value).

Now, the presettings for the tool calibration are completed.

Position value displayed in X Xm

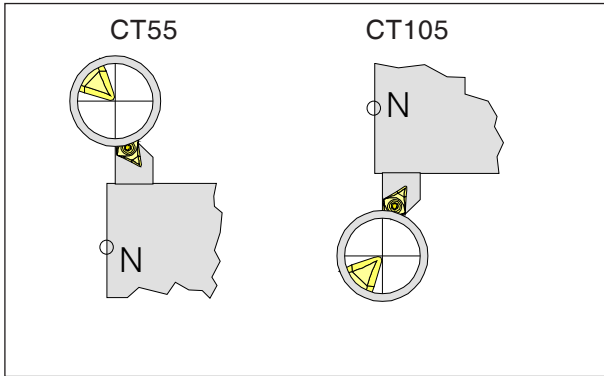

Traversing the tool tip into the cross hairs

2.) Tool calibration:

- Switch over to the NC mode and swivel in the first tool you wish to calibrate. Traverse the tool tip into the cross hairs.

- Switch over to the CAM mode and select the tool station in the tool calibration or create a new one by means of the soft key "Insert tool F1". Use the mouse button or the tabulator key to select any input box in the right-hand screen window. Confirm both X and Z with the enter key, so that the measured values will be captured.

- Use the soft key "Technology F6" to alter or complete the cutting data.

- Use the soft key "Edge F7" to check or alter the tool radius.

Calibrate all further tools as described under point 2.).

Then, set the workpiece zero point (with calibrated tools).

Tool
insertName
changeGeo-
metry

Werkzeugvermessung

Werkzeuglänge in X

X	148.000	F	0.00
Z	334.000	S	0
T	0	D	1

toolturn.tab >>

T.D	TOOLNAME
1.1	Schlichtstahl SDNC N 12
1.2	Gewindestahl NL12-3 R
1.3	Schruppstahl SCAC L 121
2.1	Schlichtstahl SVJC R 12
2.2	Schlichtstahl SDJC L 12
3.1	

[END]

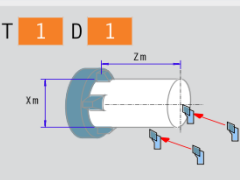

X_m 0.000 Z_m 0.000

Werkzeugverschiebungen

X	0.000	Z	0.000
I	0.000	K	0.000

X über- F1
nehmen

Z über- F2
nehmen

Werkzeug F3
Tabelle

Techno- F6
logie

Schnel- F7
de

Zurück F8

X trans-
ferZ trans-
fer

Tool measurement with scratching method

- Press the softkey.
- Enter the tool name.
- Enter the X_m value of the reference part.
- Find out the Z_m value (length from machine zero point to place surface) of the reference piece:
 - Swing out an empty tool place.
 - Position the tool turning table on the plane surface of the reference piece.
 - Enter the current Z position in Z_m.
 - Release the tool turner.
 - Swing out the first tool.

- Scratch the tool against the circumference of the workpiece and press the softkey.
- Scratch the tool against the end face of the workpiece and press the softkey.
- The tool is now measured. CAMConcept updates the X and Z data and sets the values for I and K to 0.
- Define the tool technology data as required for the relevant tool types.

Note:

The data X, Z indicate the dimensions of the tool in X and Z. The data I, K indicate the correction factor which has to be taken into account by CAMConcept in order to compensate for tool wear.

CAMConcept adds the value of the correction factor (I, K) to the length (X, Z) in order to obtain the actual tool length (X+I) and (Z+K) it needs to use.

The value "I" (correction factor for longitudinal wear in the X-direction) must be expressed in diameters.



Unmachined part

Once you have clicked on the icon you can define the dimensions of the unmachined part. It is also possible to activate the entered unmachined part dimensions when creating a new project.

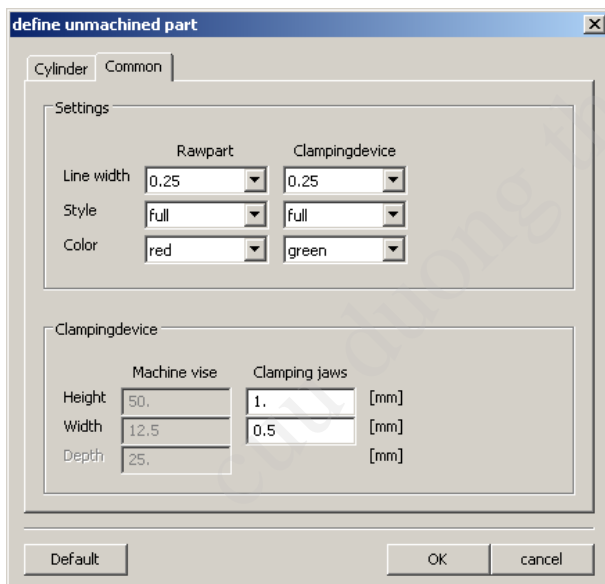
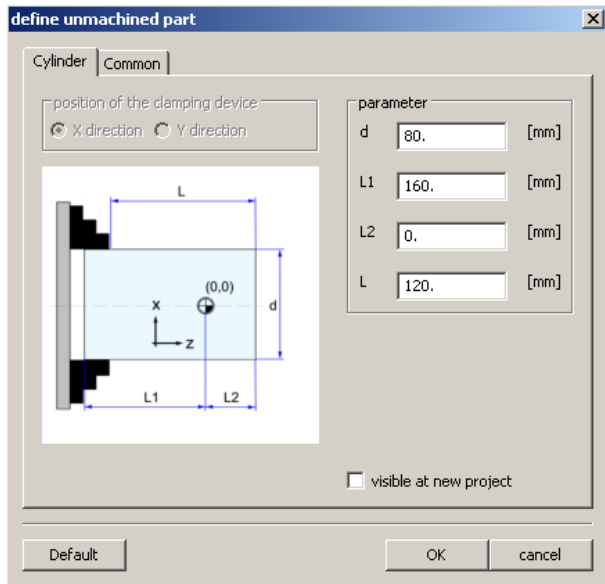

In the "General" tab you can specify the line width, line style and colour of the unmachined part.

In addition, you can also define the dimensions of the clamping device for the 2D simulation.

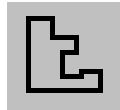

Entering a contour

When selecting working cycles, the definition of a contour to be machined is expected. A contour must be defined before.

Defined contours are filed in the window "Working steps". The saved contours can be renamed or deleted.



Follow contour - segments

For geometries having a complex structure it may be easier to define the contour by selecting single segments of an element (e.g. many intersection points).

After having selected the symbol, you can use the mouse to define drawing elements and segments of elements as contour. In case CAMConcepts offers several possibilities (e.g. intersection points), choose the further course of the contour by mouse click.

The selected elements and segments change their colour.

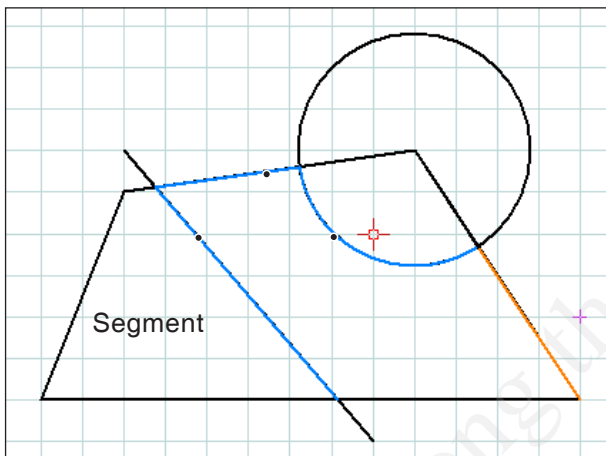

Connection of single segments



Follow contour - elements

CAMConcept is able to recognize coherent drawing geometries (elements with the same starting or end point) and consequently a contour. This makes the contour definition very easy.

After having selected the symbol, you can define coherent drawing elements as contour by means of the mouse. CAMConcepts starts connecting elements until there are various possibilities (e.g. branches) to choose from. Select the further course of the contour by mouse click.

The selected coherent elements change their colour.

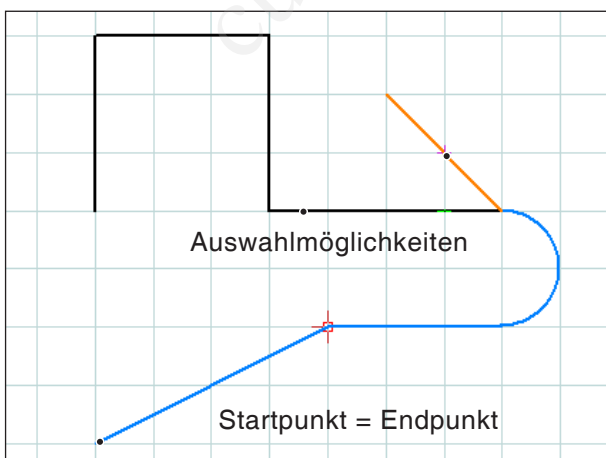

Connection of elements with the same starting or end point



Save contour

CAMConcept recognizes coherent contours and automatically saves them in the window "Working steps".

After selection by means of the mouse, this symbol enables to define contours that have not been recognized automatically.



Cancel contour

With this symbol you can cancel already selected elements (elements with changed colour). The contour will not be saved.

**Note:**

You can cancel one element each of already selected elements (elements with changed colour) by means of the right mouse button. The contour can always be saved.

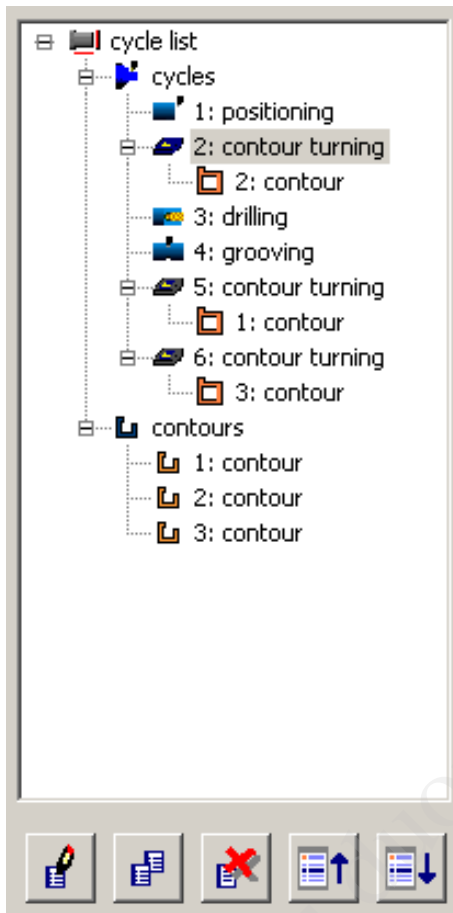

Editing window for cycles and contours

Cycles

Defining cycles

The icon list shows the various cycle groups.

- Select cycle group.
- Select cycle.
- Enter all required parameters.
- Terminate the input with the soft key "Capture F8".

After having defined the machining cycles, they will be saved one after the other in the right-hand window "Machining steps".

Contours and hole patterns that have already been defined are saved in this window as well (see chapter ("Enter contour" or "Hole pattern")



Edit selected cycle

This symbol enables to edit a cycle again that has been defined and stored before. CAMConcept switches to the cycle window.

Press the Soft key "Capture F8" to end the editing process. CAMConcept will return to the initial display mode.



Copy selected entry

This symbol enables to copy a stored cycle or a contour. The copy will be put at the end of the cycle list or contour list.

A cycle having been deleted by mistake can be restored by means of the symbol "Undo".



Delete selected entry

This symbol enables to delete a stored cycle or a contour. You can only delete contours that are or not linked in machining cycles.

Cycles and contours that have been deleted by mistake can be restored by means of the symbol "Undo".



Shift cycle

These symbols enable to alter the machining sequence of the stored cycles.

2D simulation



Switch traversing motion display ON/OFF

You can check the programmed machining cycles at any time in a 2D simulation. CAMConcept draws all 2D traversing motions of the tools.

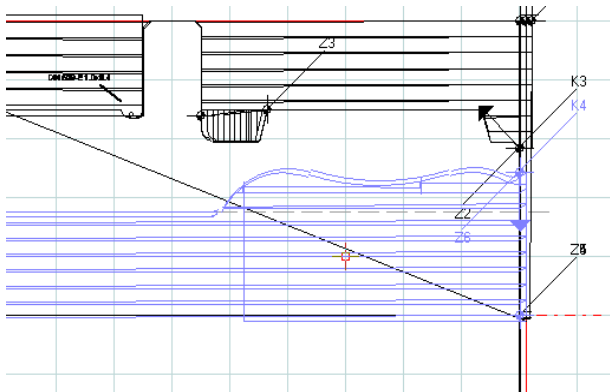

Tool traversing motions - 2D-simulation

2D-simulation of a cycle

If the cycle has been selected in the list, it can be run in the 2D simulation via NC-Start (with display of one tool).



Alarms of the 2D simulation

This symbol signals that CAMConcept has found one or more errors in the 2D simulation. Press the symbol to open the alarm window. The alarm messages are listed in the alarm window. With "Delete" the alarms are acknowledged and deleted. With "OK" the alarms are confirmed and remain in the alarm list.

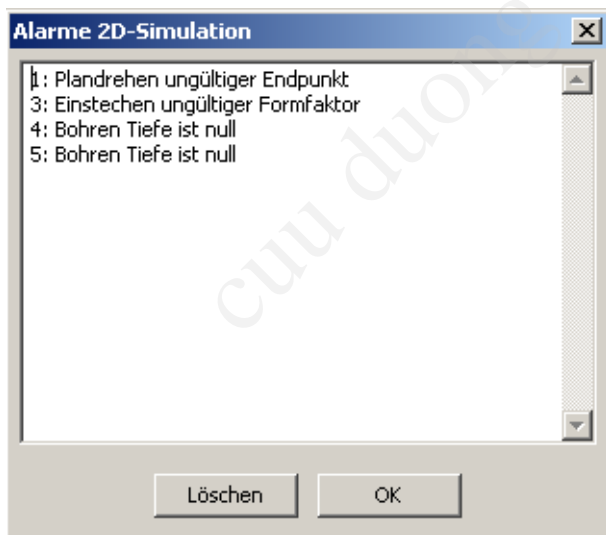

**2D simulation start**

This icon is used to start the dynamic simulation. The tool movements are displayed.

**2D simulation reset**

With this symbol the simulation and the CNC program are aborted and they return to their initial state.

**2D simulation stop**

With this symbol the simulation and the CNC program are stopped. The simulation can be continued by means of the symbol "NC start".

**2D simulation single block on/off**

This symbol enables to stop the simulation after every block. The simulation can be continued by means of the symbol "NC start".

Geo-
metrie

Input of geometry data

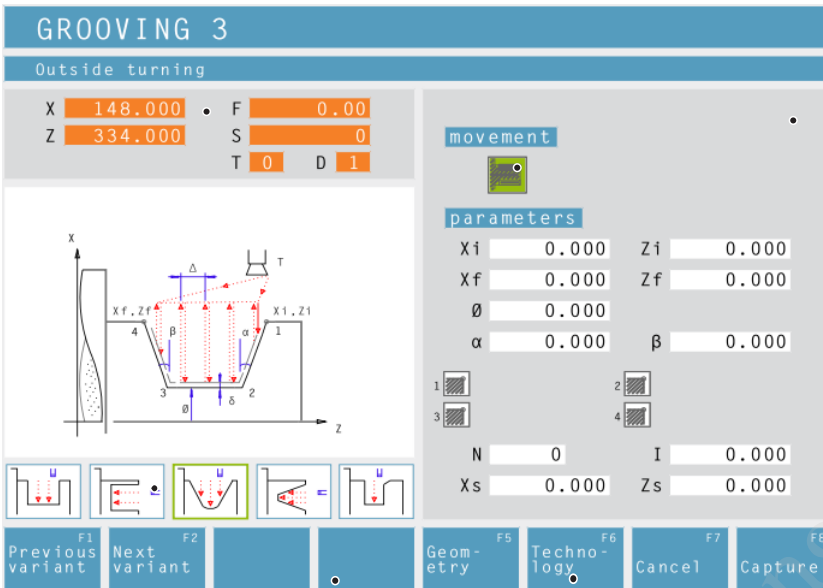

Current actual values

Input box for geometry data:
Use the mouse or the cursor keys to select the boxes.

Select boxes: can be selected by means of the mouse or the cursor keys and can be shifted by pressing the left mouse button or the key combination "Strg + F".

Input of geometry data

Soft key for input of technology data.

The symbols display the cycles that are additionally available in the respective cycle group.

Softkey for copying the ACTUAL values (X, Z) to the selected input field.

Note:

Use the mouse or the soft keys "Prior variant F1" or "Next variant F2" to select further cycles in the cycle group.

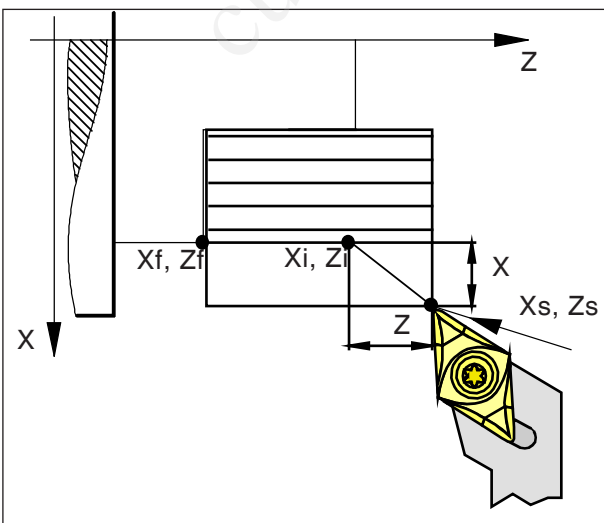

Safety distance X_s, Z_s

Safety distance

In order to prevent the risk of collisions with the workpiece, an approach point can be defined which is approached before the starting point of the cycle.

The safety distance X_s, Z_s indicates the position of this approach point in relation to the starting point of the cycle.

The safety distance X_s is always programmed as a radius value.



Input of technology data

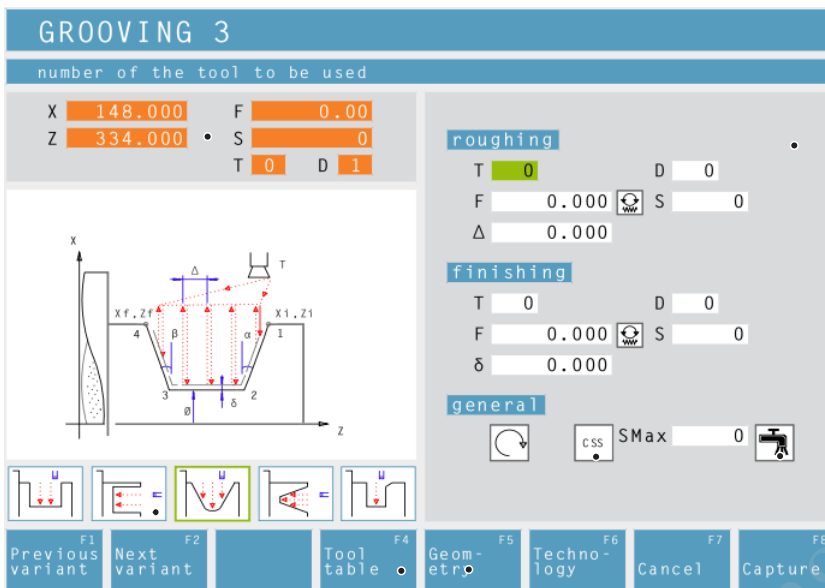

Current actual value

Input box for technology data: Selection of the boxes by means of the mouse or the cursor keys.

Select boxes: can be selected with the mouse or with the cursor keys. They can be activated or deactivated by pressing the left mouse button or the key combination "Strg + F".

Coolant on / off

Shortcut to the tool data.

Soft key for the input of geometry data.

Speed [rpm]

The speed is entered under the parameter S. You can program different speeds for the roughing and finish-machining passes.

Direction of rotation of the spindle

Clockwise / anti-clockwise



Constant speed [rpm] / cutting speed [m/min]

Set the constant speed (as rpm), the constant cutting speed (as a constant surface speed, CSS) and a maximum speed Smax.



Feed rate [mm/revolution]

The working feed is entered under the parameter F.

You can program different feed rates for the roughing and finish-machining passes.

Tool

Enter the tool and tool correction under T and D (multiple correction values are possible per tool).

In the case of machining cycles (e.g. longitudinal turning) you can program different tools for the roughing and finish-machining passes (see chapter E, "Tool measurement"). Click on the "Tool table" softkey to check or edit the tool data.

The symbols display the additionally available cycles of the corresponding cycle group.

Complete machining

Enter a tool for roughing and finish-machining. Both processes are carried out one after the other with the relevant settings and tools.

For roughing and finish-machining you can select different feed rates, speeds and tools. When you select tools which have already been defined, the corresponding speeds and feed rates are pre-entered as suggested entries which you can subsequently change if required.

If different tools are specified for roughing and finish-machining then the tool holder automatically moves to a tool change position.

Roughing

Enter the tool T0 as the finish-machining tool. This prevents the finish-machining cycle from being performed.

A defined oversize for finish-machining is taken into account during roughing.

Finish-machining

Enter the tool T0 as the roughing tool. This prevents the roughing cycle from being performed.

Coolant

Switch ON / OFF



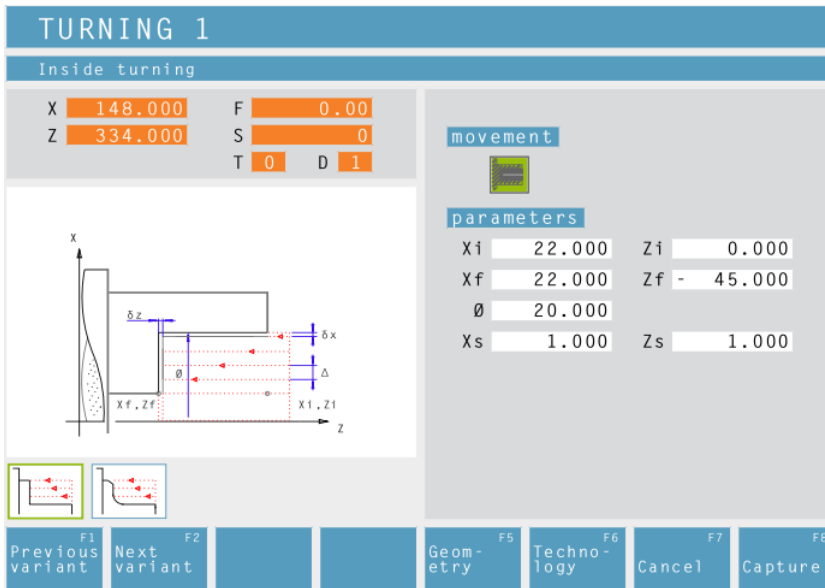

Turning Cycle 1



Selection of the cycle from the cycle group by means of the soft keys "Previous variant" and "Next variant".



Moving direction:

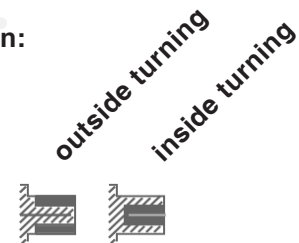

Coordinates (Xi, Zi)

Coordinates of the starting point

Coordinates (Xf, Zf)

Coordinates of the end point

Remaining diameter (\emptyset)

Final turning diameter

Safety distance (Xs, Zs)



Then, please enter all necessary technological data (tool number, direction of rotation, feed rate, spindle speed).

Cutting depth for roughing (Δ)

Lateral distance by which the tool is shifted during roughing.

Finishing offset in the X axis (δx)

Offset that should remain during roughing.

Finishing offset in the Z axis (δz)

Offset that should remain during roughing.

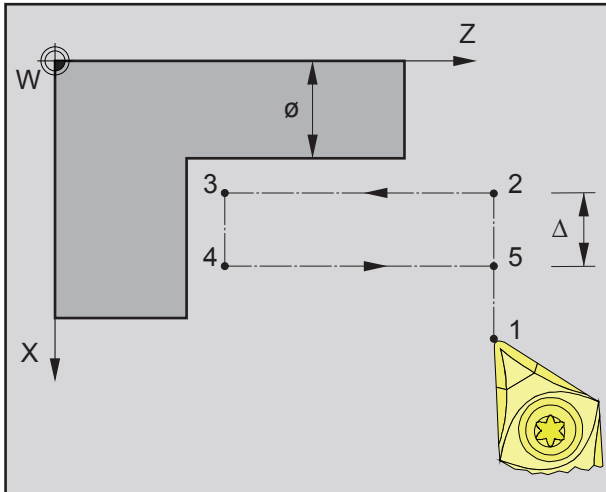

Sequence of an individual turning operation during roughing

Cycle Description

Roughing

- 1 The tool moves in rapid traverse to the safety distance (X_s, Z_s).
- 2 The tool with roughing feed then rough-machines several turning operations in succession. In this, each time the tool shifts the roughing infeed by (Δ) until the programmed slide allowances (δ_x, δ_z) are reached.

Finishing

- 3 If another tool was programmed for the finishing, a tool change will take place at the tool change point.
- 4 The tool with finishing feed then finish-machines an individual turning operation on the remaining diameter (\emptyset).
- 5 At the end, the tool will be pulled back to the safety distance (X_s, Z_s) in rapid traverse.

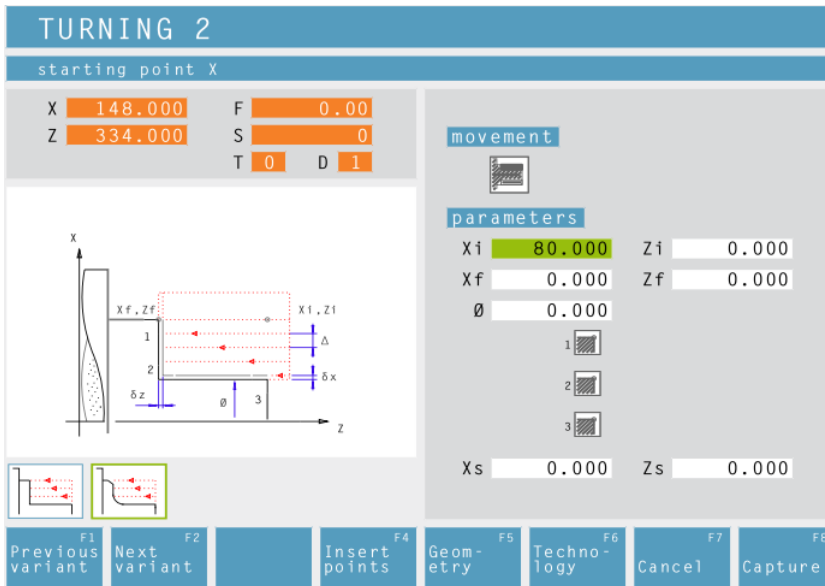

Turning Cycle 2



Selection of the cycle from the cycle group by means of the soft keys „Previous variant“ and „Next variant“.



Moving direction:

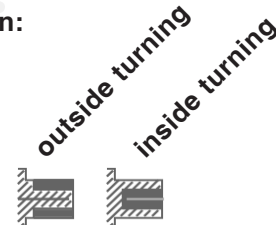

Corner rounding:

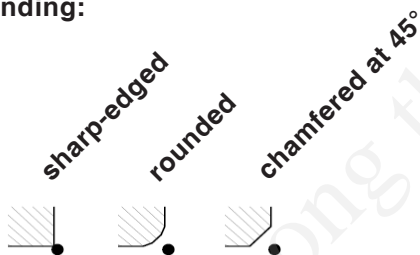

Coordinates (Xi, Zi)

Coordinates of the starting point

Coordinates (Xf, Zf)

Coordinates of the end point

Remaining diameter (Ø)

Final turning diameter

Safety distance (Xs, Zs)



Then, please enter all necessary technological data (tool number, direction of rotation, feed rate, spindle speed).

Cutting depth for roughing (Δ)

Lateral distance by which the tool is shifted during roughing.

Finishing offset in the X axis (δx)

Offset that should remain during roughing.

Finishing offset in the Z axis (δz)

Offset that should remain during roughing.

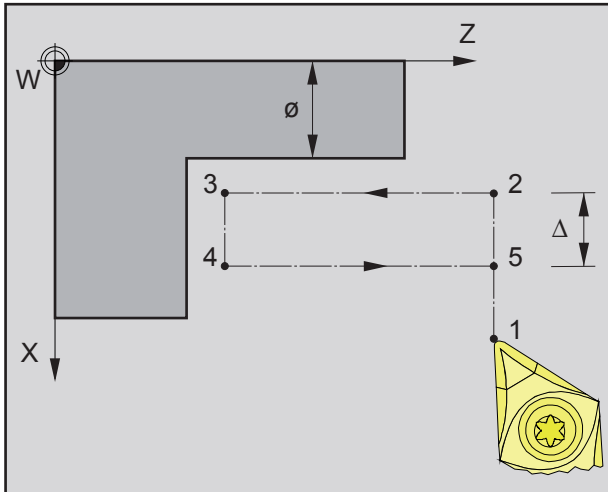

Sequence of an individual turning operation during roughing

Cycle Description

Roughing

- 1 The tool moves in rapid traverse to the safety distance (X_s, Z_s).
- 2 The tool with roughing feed then rough-machines several turning operations in succession. In this, each time the tool shifts the roughing infeed by (Δ) until the programmed slide allowances (δ_x, δ_z) are reached.

Finishing

- 3 If another tool was programmed for the finishing, a tool change will take place at the tool change point.
- 4 The tool with finishing feed then finish-machines an individual turning operation on the remaining diameter (\emptyset).
- 5 At the end, the tool will be pulled back to the safety distance (X_s, Z_s) in rapid traverse.

FACING 1

starting point X

X	148.000	F	0.00
Z	334.000	S	0
T	0	D	1

parameters

Xi	40.000	Zi	- 20.000
Xf	0.000	Zf	- 30.000
Ø	20.000		
Xs	1.000	Zs	1.000

Previous variant (F1) Next variant (F2)

Previous variant (F1) Next variant (F2) Insert points (F4) Geometry (F5) Technology (F6) Cancel (F7) Capture (F8)

Facing Cycle 1

Previous variant (F1) Next variant (F2)

Selection of the cycle from the cycle group by means of the soft keys „Previous variant“ and „Next variant“.

Geometry

Coordinates (Xi, Zi)

Coordinates of the starting point

Coordinates (Xf, Zf)

Coordinates of the end point

Diameter (Ø)

Turning diameter (negative values are allowed)

Safety distance (Xs, Zs)

Technology (F6)

Then, please enter all necessary technological data (tool number, direction of rotation, feed rate, spindle speed).

Cutting depth for roughing (Δ)

Lateral distance by which the tool is shifted during roughing.

Finishing offset in the X axis (δx)

Offset that should remain during roughing.

Finishing offset in the Z axis (δz)

Offset that should remain during roughing.

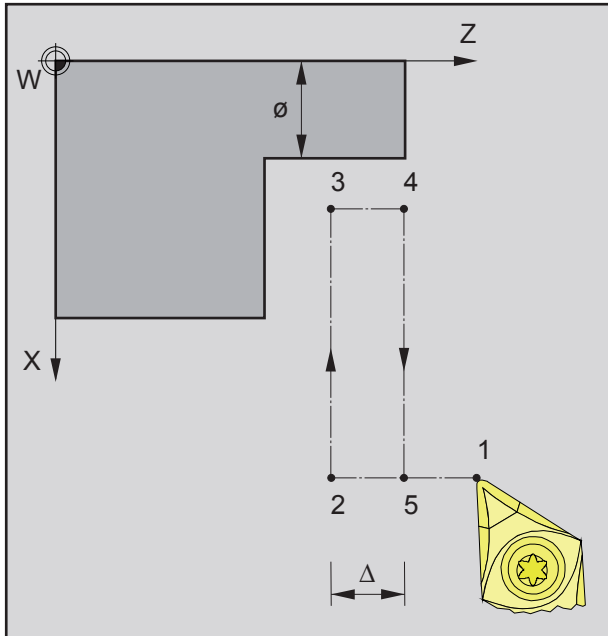

Sequence of an individual facing operation during roughing

Cycle Description

Roughing

- 1 The tool moves in rapid traverse to the safety distance (X_s, Z_s).
- 2 The tool with roughing feed then rough-machines several facing operations in succession. In this, each time the tool shifts the roughing infeed by (Δ) until the programmed slide allowances (δ_x, δ_z) are reached.

Finishing

- 3 If another tool was programmed for the finishing, a tool change will take place at the tool change point.
- 4 The tool with finishing feed then finish-machines an individual facing operation on the remaining diameter (\varnothing).
- 5 At the end, the tool will be pulled back to the safety distance (X_s, Z_s) in rapid traverse.

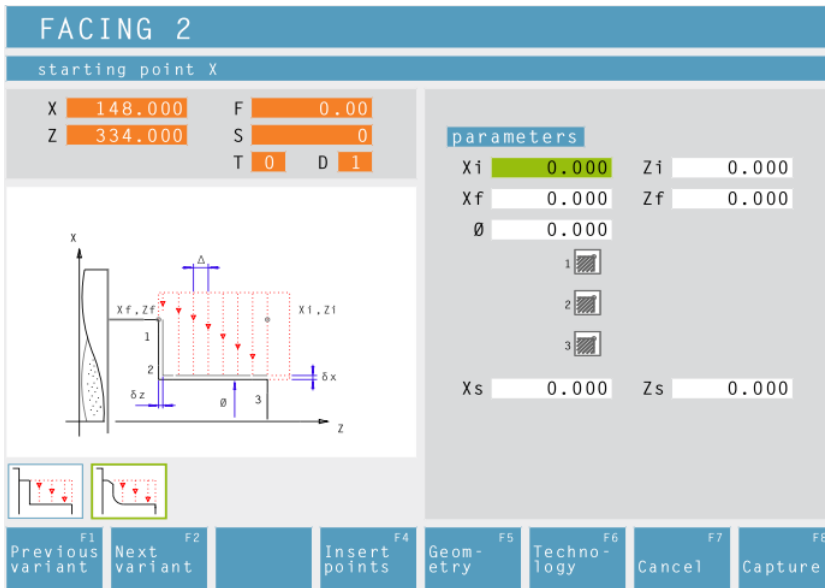

Facing Cycle 2



Selection of the cycle from the cycle group by means of the soft keys „Previous variant“ and „Next variant“.

Geom-
etry

Coordinates (Xi, Zi)

Coordinates of the starting point

Coordinates (Xf, Zf)

Coordinates of the end point

Diameter (Ø)

Turning diameter (negative values are allowed)

Corner rounding:

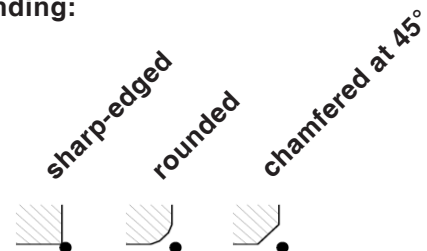

Safety distance (Xs, Zs)

Techno-
logy

Then, please enter all necessary technological data (tool number, direction of rotation, feed rate, spindle speed).

Cutting depth for roughing (Δ)

Lateral distance by which the tool is shifted during roughing.

Finishing offset in the X axis (δx)

Offset that should remain during roughing.

Finishing offset in the Z axis (δz)

Offset that should remain during roughing.

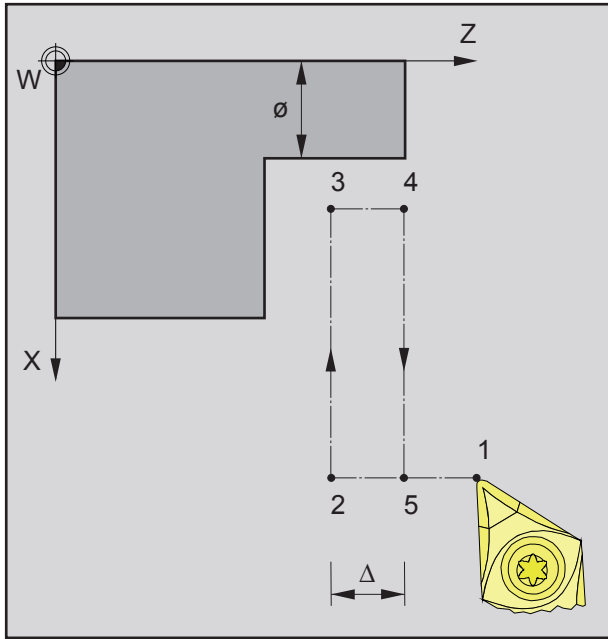

Sequence of an individual facing operation during roughing

Cycle Description

Roughing

- 1 The tool moves in rapid traverse to the safety distance (X_s, Z_s).
- 2 The tool with roughing feed then rough-machines several facing operations in succession. In this, each time the tool shifts the roughing infeed by (Δ) until the programmed slide allowances (δ_x, δ_z) are reached.

Finishing

- 3 If another tool was programmed for the finishing, a tool change will take place at the tool change point.
- 4 The tool with finishing feed then finish-machines an individual facing operation on the remaining diameter (\varnothing).
- 5 At the end, the tool will be pulled back to the safety distance (X_s, Z_s) in rapid traverse.

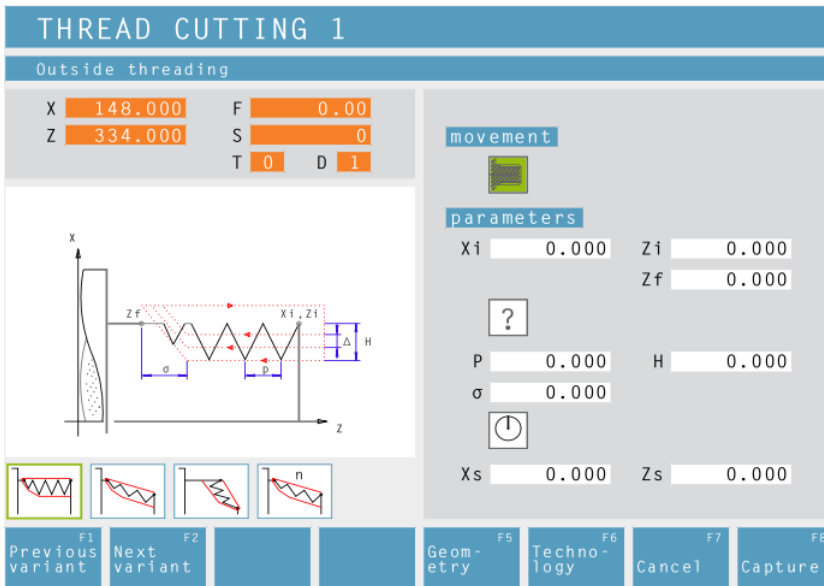

Thread Cutting 1



Selection of the cycle from the cycle group by means of the soft keys „Previous variant“ and „Next variant“.

This cycle enables to machine longitudinal threads (inside and outside).



Coordinates (Xi, Zi)

Coordinates of the starting point of the thread

Coordinate (Zf)

Coordinate of the end point of the thread

Thread type

You can choose among the following standardized thread types:

Free pitch thread

M (S.I.) Normal pitch metric thread

M (S.I.F.) Fine pitch metric thread

B.S.W. (W) Normal pitch Withworth thread

B.S.F. Fine pitch Withworth thread

U.N.C. Normal pitch unified American thread

U.N.F. Fine pitch unified American thread

Note:

With the thread type „free pitch thread“ the thread pitch P and the thread depth H can be freely chosen.

With all other thread types the thread pitch P and the thread depth H will be automatically preset with standardized values after input of the thread diameter ϕ .

In case a thread diameter is entered which is not standardized, EASY CYCLE will automatically set the next standardized diameter.

Thread diameter (ϕ)

Thread pitch (P)

Depth of thread (H)

Thread runout (σ)

Starting angle (W)

Position of the spindle

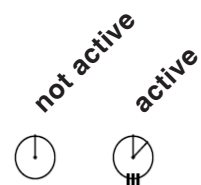

Safety distance (Xs, Zs)



Then, please enter all necessary technological data (tool number, direction of rotation, spindle speed).

THREAD CUTTING 1

number of the tool to be used

X	148.000	F	0.00
Z	334.000	S	0
T	0	D	1

machining

T 0 D 0

S 0

Δ 0.000

Δmin 0.000

general

F1 Previous variant

F2 Next variant

F4 Tool table

F5 Geom-etry

F6 Techno-logy

F7 Cancel

F8 Capture

Maximum cutting depth (Δ)

Maximum cutting depth by which the tool is shifted during roughing.

Minimum cutting depth (Δmin)

Minimum cutting depth by which the tool is shifted during roughing.

Repeat last threading pass

In order to observe tolerances or to remove a fin, it is possible to repeat the last threading pass without infeed.



Cycle Description

- 1 According to the spindle's chosen direction of rotation, a right or left thread will be turned.
- 2 The tool moves in rapid traverse to the safety distance (Xs, Zs).
- 3 The thread will be cut in several radial grooving operations until the thread depth (H) is reached. The infeed (Δ) of the individual operations depends on which operation it is (Δ , $\Delta\sqrt{2}$, $\Delta\sqrt{3}$, $\Delta\sqrt{4}$, ...). If a decreasing infeed is lower than the minimum infeed (Δ_{min}), at least (Δ_{min}) will be fed in.
- 4 If selected - the tool repeats the last threading operation.
- 5 At the end, the tool will be pulled back to the safety distance (Xs, Zs) in rapid traverse.

THREAD CUTTING 2

Outside threading

X	148.000	F	0.00
Z	334.000	S	0
T	0	D	1

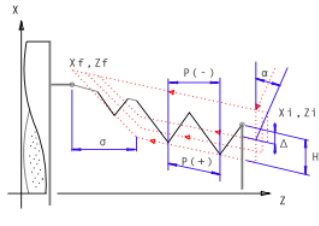

movement

parameters

Xi	0.000	Zi	0.000
Xf	0.000	Zf	0.000
?			
P	0.000	H	0.000
σ	0.000		
⏸			
Xs	0.000	Zs	0.000

F1
Previous variant

F2
Next variant

F5
Geometry

F6
Technology

F7
Cancel

F8
Capture

Thread Cutting 2



Selection of the cycle from the cycle group by means of the soft keys „Previous variant“ and „Next variant“.

This cycle enables to machine tapered threads (inside and outside).

Geometry

Moving direction:



Coordinates (Xi, Zi)

Coordinates of the starting point of the thread

Coordinates (Xf, Zf)

Coordinates of the end point of the thread

Thread type

You can choose among the following standardized thread types:

- ? Free pitch thread
- 60
MM M (S.I.) Normal pitch metric thread
- 60
MM M (S.I.F.) Fine pitch metric thread
- 55
INCH B.S.W. (W) Normal pitch Withworth thread
- 55
INCH B.S.F. Fine pitch Withworth thread
- 60
INCH U.N.C. Normal pitch unified American thread
- 60
INCH U.N.F. Fine pitch unified American thread

Thread diameter (Ø)

Thread pitch (P)

- + pos. arithmetic sign: dimension in direction of the thread
- neg. arithmetic sign: dimension in direction of the Z axis

Depth of thread (H)

Thread runout (σ)

Starting angle (W)

Position of the spindle

Safety distance (Xs, Zs)

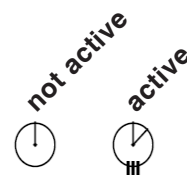

Note:
 With the thread type „free pitch thread“ the thread pitch P and the thread depth H can be freely chosen.
 With all other thread types the thread pitch P and the thread depth H will be automatically preset with standardized values after input of the thread diameter Ø.
 In case a thread diameter is entered which is not standardized, EASY CYCLE will automatically set the next standardized diameter.





Then, please enter all necessary technological data (tool number, direction of rotation, spindle speed).

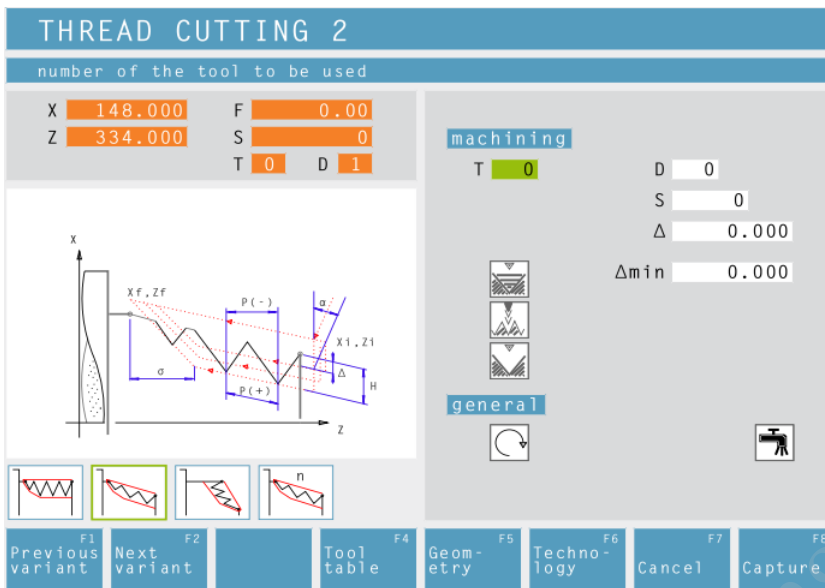

Maximum cutting depth (Δ)

Maximum cutting depth by which the tool is shifted during roughing.

Minimum cutting depth (Δ_{min})

Minimum cutting depth by which the tool is shifted during roughing.

Angle of infeed (α)

Half flank angle (normally 30°)

Decreasing or constant cutting depth

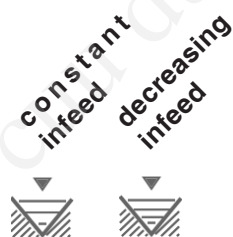

Types of infeed:



Repeat last threading pass

In order to observe tolerances or to remove a fin, it is possible to repeat the last threading pass without infeed.

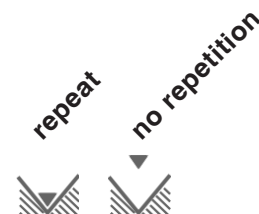

Cycle Description

- 1 According to the spindle's chosen direction of rotation, a right or left thread will be turned.
- 2 The tool moves in rapid traverse to the safety distance (Xs, Zs).
- 3 The thread will be cut in several operations until the thread depth (H) is reached.
The icon-selected infeed is carried out:
 - at a constant infeed each time of (Δ),
 - at an infeed decreasing by (Δ , $\Delta\sqrt{2}$, $\Delta\sqrt{3}$, $\Delta\sqrt{4}$, ...). If a decreasing infeed is lower than the minimum infeed (Δ_{min}), at least (Δ_{min}) will be fed in.The icon-selected infeed type will be taken into account.
- 4 If selected - the tool repeats the last threading operation.
- 5 At the end, the tool will be pulled back to the safety distance (Xs, Zs) in rapid traverse.



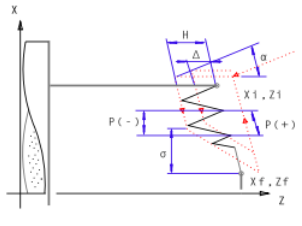

THREAD CUTTING 3

starting point for thread in X

X	148.000	F	0.00
Z	334.000	S	0
T	0	D	1



parameters	
X1	0.000
Z1	0.000
Xf	0.000
Zf	0.000
P	0.000
H	0.000
σ	0.000
	
Xs	0.000
Zs	0.000

			
F1 Previous variant	F2 Next variant	F4 Insert points	F5 Geom- etry

Thread Cutting 3



Selection of the cycle from the cycle group by means of the soft keys „Previous variant“ and „Next variant“.

This cycle enables to machine face threads.

Geom-etry

Coordinates (Xi, Zi)

Coordinates of the starting point of the thread

Coordinates (Xf, Zf)

Coordinates of the end point of the thread

Thread pitch (P)

+ pos. arithmetic sign: dimension in direction of the thread

- neg. arithmetic sign: dimension in direction of the Z axis

Depth of thread (H)

Thread runout (σ)

Starting angle (W)

Position of the spindle

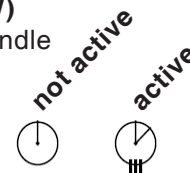

Safety distance (Xs, Zs)

Note:

With the thread type „free pitch thread“ the thread pitch P and the thread depth H can be freely chosen.

With all other thread types the thread pitch P and the thread depth H will be autoMatically preset with standardized values after input of the thread diameter ϕ .

In case a thread diameter is entered which is not standardized, EASY CYCLE will automa-tically set the next standardized diameter.



Then, please enter all necessary technological data (tool number, direction of rotation, spindle speed).

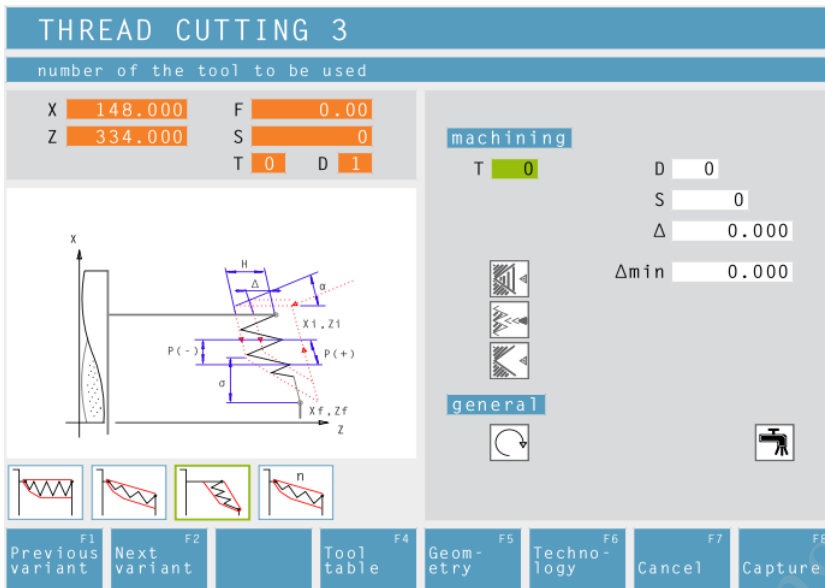

Maximum cutting depth (Δ)

Maximum cutting depth by which the tool is shifted during roughing.

Minimum cutting depth (Δ_{min})

Minimum cutting depth by which the tool is shifted during roughing.

Angle of infeed (α)

Half flank angle (normally 30°)

Decreasing or constant cutting depth

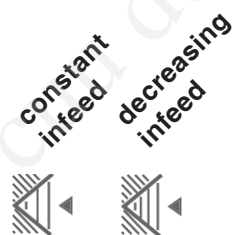

Types of infeed:

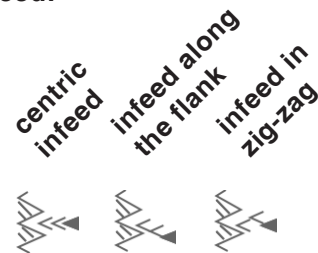

Repeat last threading pass

In order to observe tolerances or to remove a fin, it is possible to repeat the last threading pass without infeed.



Cycle Description

- 1 According to the spindle's chosen direction of rotation, a right or left thread will be turned.
- 2 The tool moves in rapid traverse to the safety distance (Xs, Zs).
- 3 The thread will be cut in several operations until the thread depth (H) is reached.
The icon-selected infeed is carried out:
 - at a constant infeed each time of (Δ),
 - at an infeed decreasing by (Δ , $\Delta\sqrt{2}$, $\Delta\sqrt{3}$, $\Delta\sqrt{4}$, ...). If a decreasing infeed is lower than the minimum infeed (Δ_{\min}), at least (Δ_{\min}) will be fed in.The icon-selected infeed type will be taken into account.
- 4 If selected - the tool repeats the last threading operation.
- 5 At the end, the tool will be pulled back to the safety distance (Xs, Zs) in rapid traverse.

MULTIPLE GEAR THREAD

Outside threading

X	148.000	F	0.00
Z	334.000	S	0
T	0	D	1

parameters

Xi	0.000	Zi	0.000
Xf	0.000	Zf	0.000
?			
P	0.000	H	0.000
N	0		
σ	0.000		
🕒			
Xs	0.000	Zs	0.000

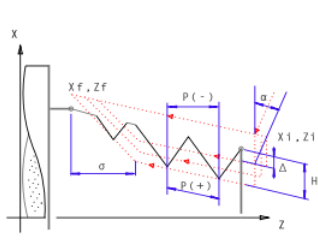

F1
Previous variant

F2
Next variant

F5
Geom-etry

F6
Techno-logy

F7
Cancel

F8
Capture

Multiple Gear Thread



Selection of the cycle from the cycle group by means of the soft keys „Previous variant“ and „Next variant“.

This cycle enables to machine outside, inside and tapered threads with any number of threads.

Moving direction:

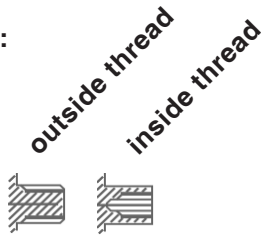

Geom-etry

Coordinates (Xi, Zi)

Coordinates of the starting point of the thread

Coordinates (Xf, Zf)

Coordinates of the end point of the thread

Thread type

You can choose among the following standardized thread types:

- ? Free pitch thread
- 60
MM M (S.I.) Normal pitch metric thread
- 60
MM M (S.I.F.) Fine pitch metric thread
- 55
INCH B.S.W. (W) Normal pitch Withworth thread
- 55
INCH B.S.F. Fine pitch Withworth thread
- 60
INCH U.N.C. Normal pitch unified American thread
- 60
INCH U.N.F. Fine pitch unified American thread

Thread diameter (Ø)

Thread pitch (P)

+ pos. arithmetic sign: dimension in direction of the thread

- neg. arithmetic sign: dimension in direction of the Z axis

Depth of thread (H)

Number of threads (N)

Thread runout (σ)

Starting angle (W)

Position of the spindle

Safety distance (Xs, Zs)



Note:

With the thread type „free pitch thread“ the thread pitch P and the thread depth H can be freely chosen.

With all other thread types the thread pitch P and the thread depth H will be autoMatically preset with standardized values after input of the thread diameter ϕ .

In case a thread diameter is entered which is not standardized, EASY CYCLE will automa-tically set the next standardized diameter.





Then, please enter all necessary technological data (tool number, direction of rotation, spindle speed).

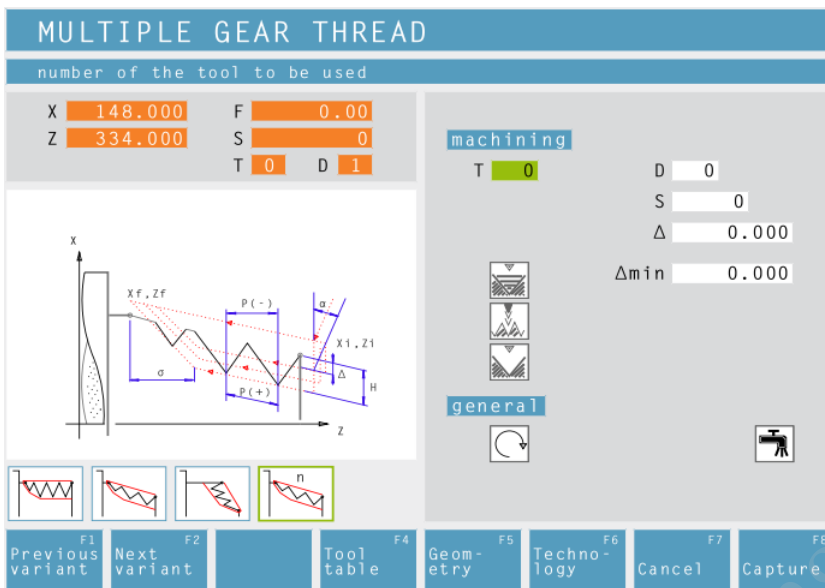

Maximum cutting depth (Δ)

Maximum cutting depth by which the tool is shifted during roughing.

Minimum cutting depth (Δ_{min})

Minimum cutting depth by which the tool is shifted during roughing.

Angle of infeed (α)

Half flank angle (normally 30°)

Decreasing or constant cutting depth



Types of infeed:

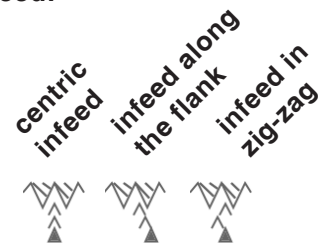

Repeat last threading pass

In order to observe tolerances or to remove a fin, it is possible to repeat the last threading pass without infeed.

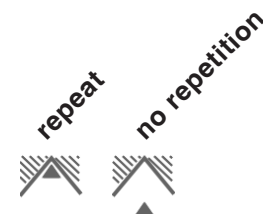

Cycle Description

- 1 According to the spindle's chosen direction of rotation, a right or left thread will be turned.
- 2 The tool moves in rapid traverse to the safety distance (Xs, Zs).
- 3 The thread will be cut in several operations until the thread depth (H) is reached.
The icon-selected infeed is carried out:
 - at a constant infeed each time of (Δ),
 - at an infeed decreasing by (Δ , $\Delta\sqrt{2}$, $\Delta\sqrt{3}$, $\Delta\sqrt{4}$, ...). If a decreasing infeed is lower than the minimum infeed (Δ_{min}), at least (Δ_{min}) will be fed in.The icon-selected infeed type will be taken into account.
- 4 If selected - the tool repeats the last threading operation.
- 5 At the end, the tool will be pulled back to the safety distance (Xs, Zs) in rapid traverse.

cuu duong than cong . com

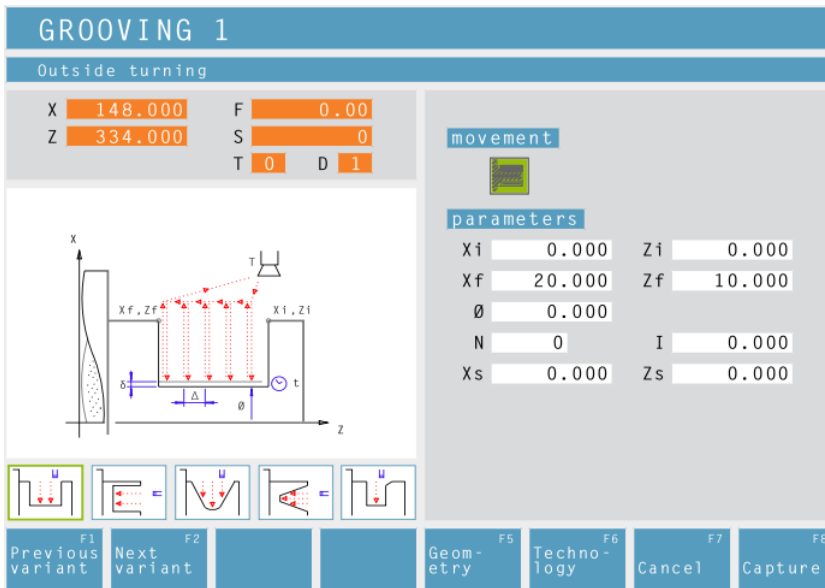

Grooving Cycle 1



Selection of the cycle from the cycle group by means of the soft keys „Previous variant“ and „Next variant“.

This cycle enables to machine a straight, radial groove.



Moving direction:

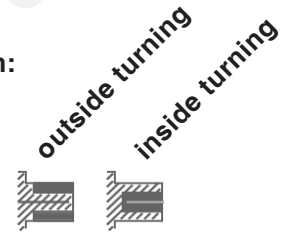

Note:
 The groove has to **be the same size or** must be larger than the tool width.
 It is absolutely necessary to enter the tool width (B) during tool calibration.
 The cutting depth for roughing Δ should be a little bit smaller than the tool width.



Coordinates (Xi, Zi)

Coordinates of the starting point

Coordinates (Xf, Zf)

Coordinates of the end point

Remaining diameter (Ø)

Final turning diameter

Number of grooves (N)

Distance between grooves (I)

Distance between two grooves (from X_{i_1}, Z_{i_1} - X_{i_2}, Z_{i_2}).

For one groove only please enter I=0.

Safety distance (Xs, Zs)

Then, please enter all necessary technological data (tool number, direction of rotation, feed rate, spindle speed).

Cutting depth for roughing (Δ)

Lateral distance by which the tool is shifted during roughing.

Dwell time (t)

Finishing offset (δ)

Offset that should remain during roughing.

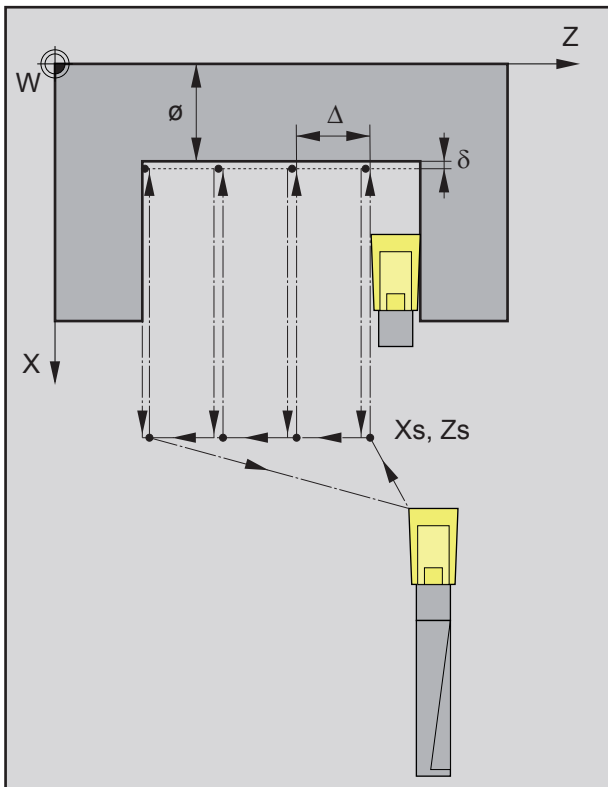

Sequence of the plunge-cutting passes during roughing

Cycle Description

Roughing

- 1 The tool moves in rapid traverse to the safety distance (X_s, Z_s).
- 2 The tool with roughing feed then rough-machines several turning operations in succession. In this, each time the tool shifts the roughing infeed by (Δ) until the programmed slide allowance (δ) is reached and lingers there for (t) - if entered.

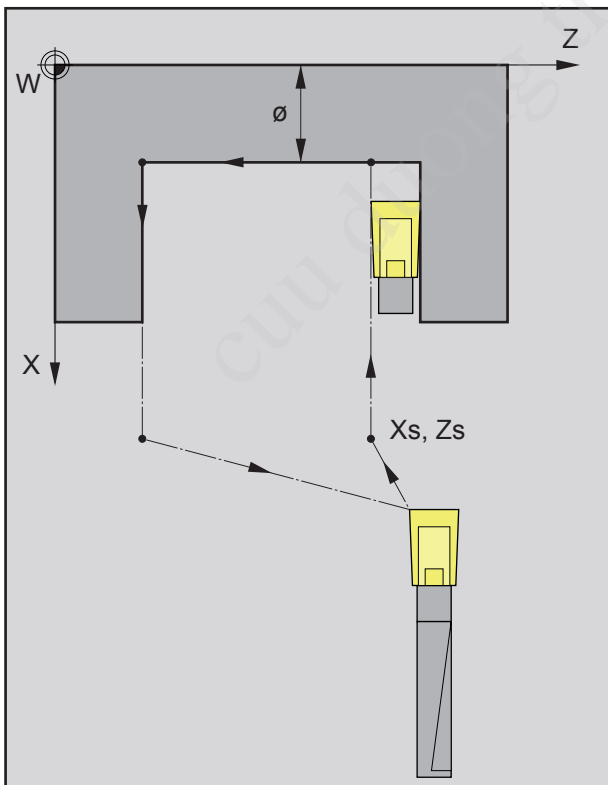

Sequence of the plunge-cutting pass during finish-machining

Finishing

- 3 If another tool was programmed for the finishing, a tool change will take place at the tool change point.
- 4 The tool with finishing feed then finish-machines an individual grooving operation on the remaining diameter (\varnothing).
- 5 At the end, the tool will be pulled back to the safety distance (X_s, Z_s) in rapid traverse.

GROOVING 2

starting point X

X	148.000	F	0.00
Z	334.000	S	0
T	0	D	1

parameters

Xi	0.000	Zi	0.000
Xf	0.000	Zf	0.000
R	0.000		
N	0	I	0.000
Xs	0.000	Zs	0.000

Previous variant F1 Next variant F2

Insert points F4 Geometry F5 Technology F6 Cancel F7 Capture F8

Grooving Cycle 2



Selection of the cycle from the cycle group by means of the soft keys „Previous variant“ and „Next variant“.

This cycle enables to machine a straight, axial groove.

Geom-
etry

Coordinates (Xi, Zi)

Coordinates of the starting point

Coordinates (Xf, Zf)

Coordinates of the end point

Depth of groove (R)

Z coordinate of the groove

Number of grooves (N)

Distance between grooves (I)

Distance between two grooves (from X_{i_1}, Z_{i_1} - X_{i_2}, Z_{i_2}). For one groove only please enter $I=0$.

Safety distance (Xs, Zs)

Note:

The groove has to **be the same size or** must be larger than the tool width.

It is absolutely necessary to enter the tool width (B) during tool calibration.

The cutting depth for roughing Δ should be a little bit smaller than the tool width.

Techno-
logy F6

Then, please enter all necessary technological data (tool number, direction of rotation, feed rate, spindle speed).

Cutting depth for roughing (Δ)

Lateral distance by which the tool is shifted during roughing.

Dwell time (t)

in seconds

Finishing offset (δ)

Offset that should remain during roughing.v

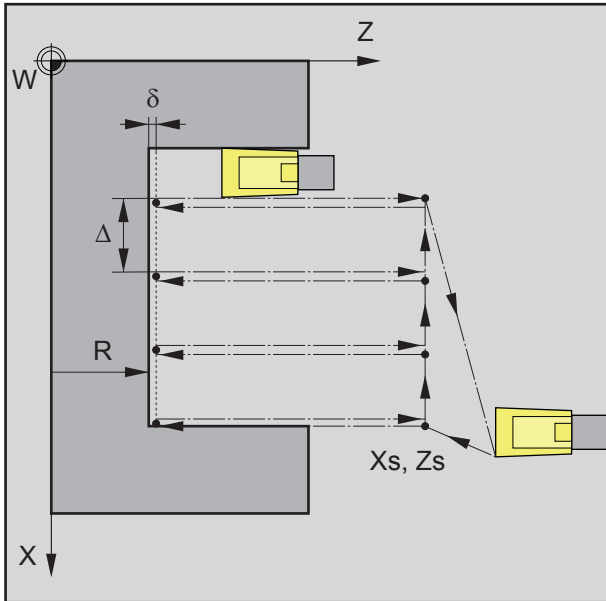

Sequence of grooving operations during roughing

Cycle Description

Roughing

- 1 The tool moves in rapid traverse to the safety distance (X_s, Z_s).
- 2 The tool with roughing feed then rough-machines several grooving operations in succession. In this, each time the tool shifts the roughing infeed by (Δ) until the programmed slide allowance (δ) is reached and lingers there for (t) - if entered.

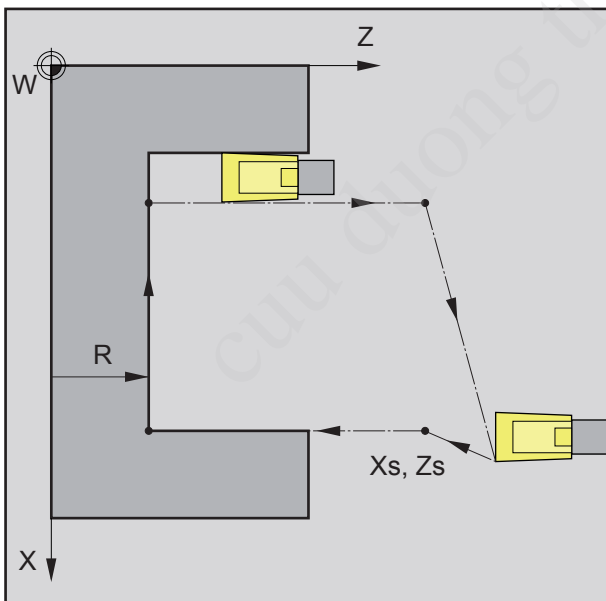

Sequence of grooving operations during finishing

Finishing

- 3 If another tool was programmed for the finishing, a tool change will take place at the tool change point.
- 4 The tool with finishing feed then finish-machines an individual grooving operation on the remaining diameter (ϕ).
- 5 At the end, the tool will be pulled back to the safety distance (X_s, Z_s) in rapid traverse.

GROOVING 3

Outside turning

X	148.000	F	0.00
Z	334.000	S	0
T	0	D	1

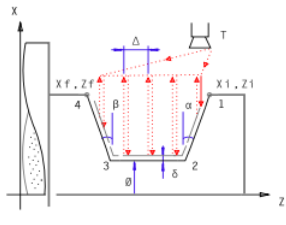

movement

parameters

Xi	0.000	Zi	0.000
Xf	0.000	Zf	0.000
Ø	0.000		
α	0.000	β	0.000
N	0	I	0.000
Xs	0.000	Zs	0.000

F1 Previous variant

F2 Next variant

Geom-etry F5

Techno-logy F6

Cancel F7

Capture F8

Grooving Cycle 3



Selection of the cycle from the cycle group by means of the soft keys „Previous variant“ and „Next variant“.

This cycle enables to machine a wedge-shaped, radial groove.



Moving direction:

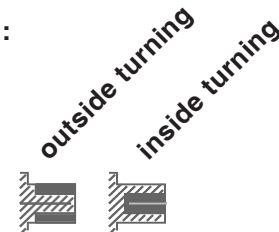

Coordinates (Xi, Zi)

Coordinates of the starting point

Coordinates (Xf, Zf)

Coordinates of the end point

Remaining diameter (Ø)

Final turning diameter

Flank angle (α)

Flank angle (β)

Corner rounding:

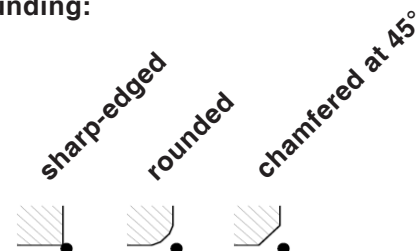

Number of grooves (N)

Distance between grooves (I)

Distance between two grooves (from X_{i_1}, Z_{i_1} - X_{i_2}, Z_{i_2}). For one groove only please enter I=0.

Safety distance (Xs, Zs)



Then, please enter all necessary technological data (tool number, direction of rotation, feed rate, spindle speed).

GROOVING 3

number of the tool to be used

X 148.000 F 0.00
 Z 334.000 S 0
 T 0 D 1

roughing
 T 0 D 0
 F 0.000 S 0
 Δ 0.000

finishing
 T 0 D 0
 F 0.000 S 0
 δ 0.000

general
 css SMax 0

Previous variant (F1) Next variant (F2) Tool table (F4) Geometry (F5) Technology (F6) Cancel (F7) Capture (F8)



Note:
 The groove has to **be the same size or** must be larger than the tool width.
 It is absolutely necessary to enter the tool width (B) during tool calibration.
 The cutting depth for roughing Δ should be a little bit smaller than the tool width.

Cutting depth for roughing (Δ)

Lateral distance by which the tool is shifted during roughing.

Finishing offset (δ)

Offset that should remain during roughing.

Cycle Description**Roughing**

- 1 The tool moves in rapid traverse to the safety distance (X_s , Z_s).
- 2 The tool with roughing feed then rough-machines several grooving operations in succession. In this, each time the tool shifts the roughing infeed by (Δ), taking into account the thread angles (α , β) until the programmed slide allowance (δ) is reached and lingers there for (t) - if entered.

Finishing

- 3 If another tool was programmed for the finishing, a tool change will take place at the tool change point.
- 4 The tool with finishing feed then finish-machines an individual grooving operation on the remaining diameter (\emptyset).
- 5 At the end, the tool will be pulled back to the safety distance (X_s , Z_s) in rapid traverse.

GROOVING 4

starting point X

X	148.000	F	0.00
Z	334.000	S	0
T	0	D	1

parameters

Xi	0.000	Zi	0.000
Xf	0.000	Zf	0.000
R	0.000		
α	0.000	β	0.000
N	0	I	0.000
Xs	0.000	Zs	0.000

F1
Previous
variant

F2
Next
variant

F4
Insert
points

F5
Geom-
etry

F6
Techno-
logy

F7
Cancel

F8
Capture

Grooving Cycle 4



Selection of the cycle from the cycle group by means of the soft keys „Previous variant“ and „Next variant“.

This cycle enables to machine a wedge-shaped, axial groove.

Geom-etry

Coordinates (Xi, Zi)

Coordinates of the starting point

Coordinates (Xf, Zf)

Coordinates of the end point

Depth of groove (R)

Z coordinate of the groove

Flank angle (α)

Flank angle (β)

Corner rounding:

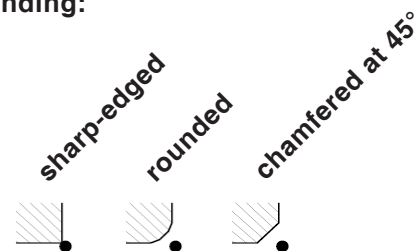

Number of grooves (N)

Distance between grooves (I)

Distance between two grooves (from X_i, Z_i - X_{i-1}, Z_{i-1}). For one groove only please enter $I=0$.

Safety distance (Xs, Zs)



Then, please enter all necessary technological data (tool number, direction of rotation, feed rate, spindle speed).

GROOVING 4

number of the tool to be used

X	148.000	F	0.00
Z	334.000	S	0
T	0	D	1

roughing

T D

F S

Δ

finishing

T D

F S

δ

general

CSS SMax

F1 Previous variant
F2 Next variant
F4 Tool table
F5 Geometry
F6 Technology
F7 Cancel
F8 Capture

Cutting depth for roughing (Δ)

Lateral distance by which the tool is shifted during roughing.

Finishing offset (δ)

Offset that should remain during roughing.

Note:
 The groove has to **be the same size or** must be larger than the tool width.
 It is absolutely necessary to enter the tool width (B) during tool calibration.
 The cutting depth for roughing Δ should be a little bit smaller than the tool width.

Cycle Description**Roughing**

- 1 The tool moves in rapid traverse to the safety distance (X_s , Z_s).
- 2 The tool with roughing feed then rough-machines several grooving operations in succession. In this, each time the tool shifts the roughing infeed by (Δ), taking into account the thread angles (α , β) until the programmed slide allowance (δ) is reached and lingers there for (t) - if entered.

Finishing

- 3 If another tool was programmed for the finishing, a tool change will take place at the tool change point.
- 4 The tool with finishing feed then finish-machines an individual grooving operation on the remaining diameter (\emptyset).
- 5 At the end, the tool will be pulled back to the safety distance (X_s , Z_s) in rapid traverse.

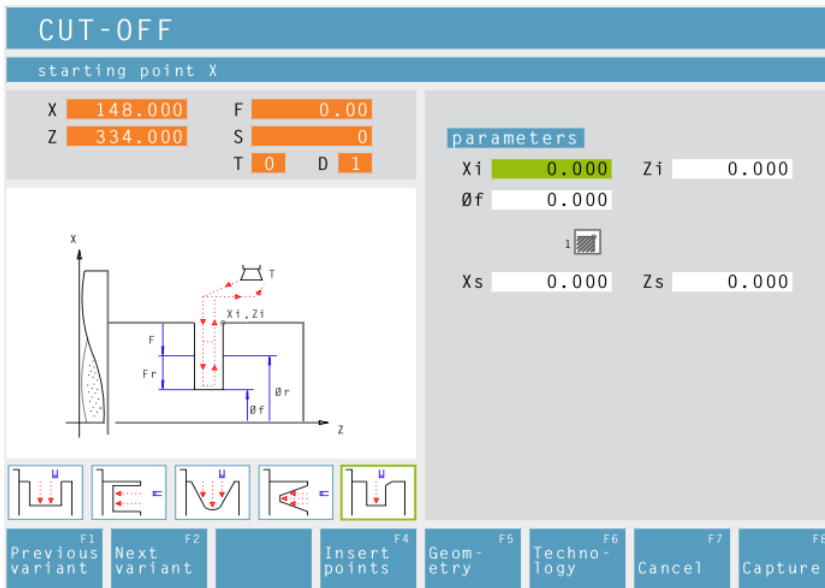

Cut-Off Cycle



Selection of the cycle from the cycle group by means of the soft keys „Previous variant“ and „Next variant“.

This cycle enables to quickly cut off turning components.



Coordinates (Xi, Zi)

Coordinates of the starting point

Diameter (Øf)

Final diameter

Corner rounding:

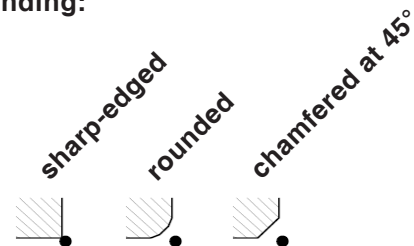

Note:
Select $\text{Øf} = 0$ to cut off workpieces.
It is absolutely necessary to enter the tool width (B) during tool calibration.

Safety distance (Xs, Zs)



Then, please enter all necessary technological data (tool number, direction of rotation, feed rate, spindle speed).

Feed rate for cutting-off cycle (Fr)

Feed rate at which the tool moves from the intermediate diameter to the final diameter. In doing so, the feed rate F is gradually adjusted to the feed rate Fr.

Diameter (Ør)

Intermediate diameter

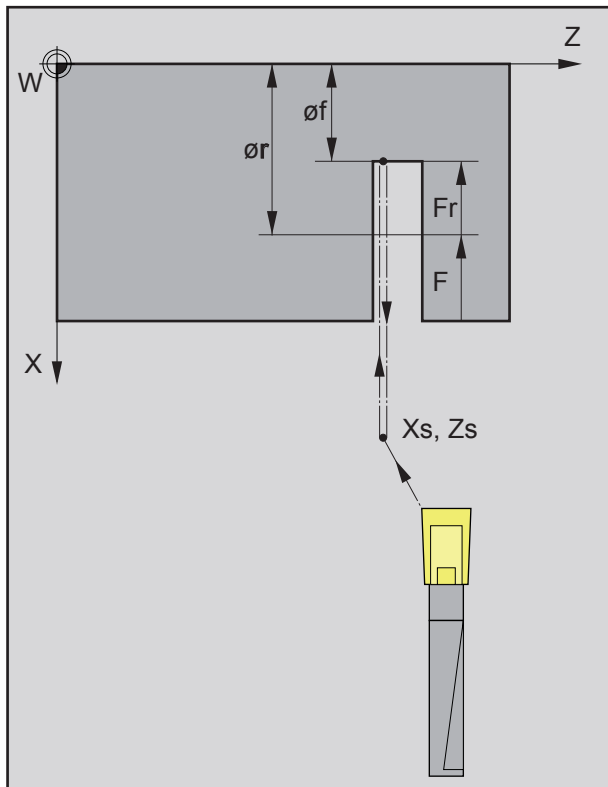

Sequence of grooving operations during cutting

Cycle Description

- 1 The tool moves in rapid traverse to the safety distance (Xs, Zs).
- 2 Then the tool with feed (F) grooves to the intermediate diameter (ør). The feed (F) is adjusted step by step to the feed (Fr) until the end diameter (øf). If selected - bevels and radii will be created if needed by multiple grooving.
- 3 At the end, the tool will be pulled back to the safety distance (Xs, Zs) in rapid traverse.

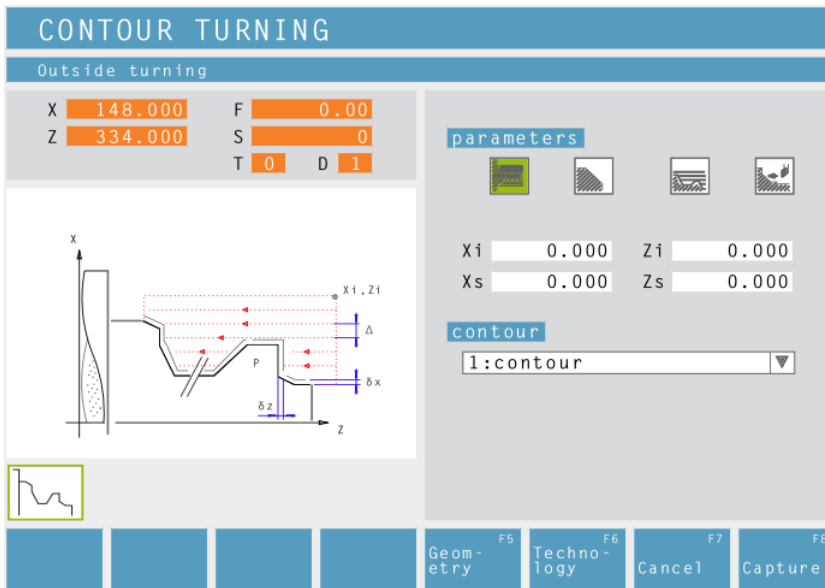

Contour Turning

This cycle enables to turn an already defined contour. Defined contours are saved in the window "machining steps".



Moving direction:

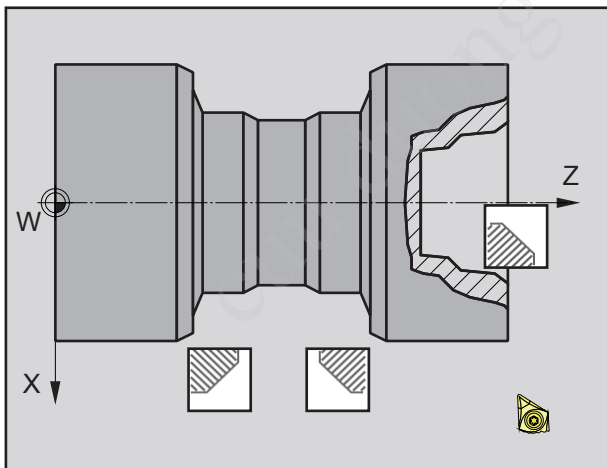
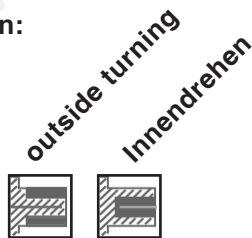

Taper position:

Please define the area in the quadrant that you wish to machine.

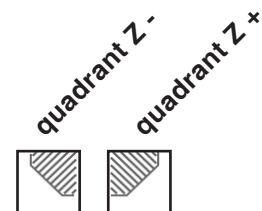

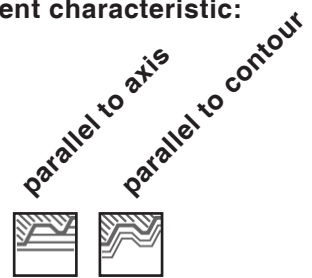
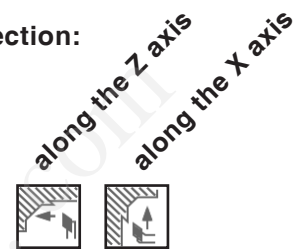
Cutting movement characteristic:**Machining direction:****Distance during 1st roughing pass (ϵ)**

Distance during parallel contour pre-roughing
With profile repetition, the material quantity that should be removed from the parent part must be defined.

Coordinates (Xi, Zi)

Coordinates of the starting point

Safety distance (Xs, Zs)**Contour**

Select a contour from the select list.

Create
contour

By pressing this soft key, you get back to the contour management to define a new contour. When going back, the new contour will be automatically selected in the list.



Then, please enter all necessary technological data (tool number, direction of rotation, feed rate, spindle speed).

CONTOUR TURNING

number of the tool to be used

X 148.000 F 0.00
 Z 334.000 S 0
 T 0 D 1

roughing
 T 0 D 0
 F 0.000 S 0
 Fb 0.000 Δ 0.000

finishing
 T 0 D 0
 F 0.000 S 0
 δ 0.000

general
 CSS SMax 0

Tool table F4 Geometry F5 Technology F6 Cancel F7 Capture F8

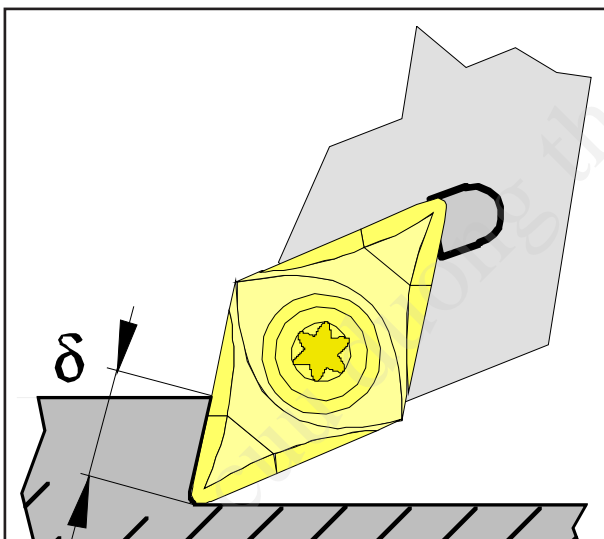

Schlichtaufmaß δ

Feed for infeed at relief cut (Fb)

Feed rate during roughing parallel to axis

Cutting depth for roughing (Δ)

Lateral distance by which the tool is shifted during roughing.

Finishing offset either by tool shape or axis:



Finishing offset (δ)

Offset that should remain during roughing.

Finishing offset in the X axis (δx)

Offset that should remain during roughing.

Finishing offset in the Z axis (δz)

Offset that should remain during roughing.

Cycle Description**Roughing**

- 1 The tool moves in rapid traverse to the safety distance (X_s , Z_s).
- 2 Then the tool with roughing feed moves to the first contour point and rough-machines axis/contour parallel several turning/facing operations in succession. In this, each time the tool shifts the roughing infeed by (Δ) until the programmed slide allowances (δ or δx , δz) are reached. With axis-parallel pre-roughing, the grooving feed (F_b) of the tool must be defined in the pockets.

Finishing

- 3 If another tool was programmed for the finishing, a tool change will take place at the tool change point.
- 4 Then the tool with finishing infeed finish-machines the contour in an individual turning operation.
- 5 At the end, the tool will be pulled back to the safety distance (X_s , Z_s) in rapid traverse.

DRILLING

Z coordinate of the drilling center

X	148.000	F	0.00
Z	334.000	S	0
T	0	D	1

parameters

Z	- 20.000	Zs	0.000
L	0.000		

F1 Previous variant
F2 Next variant
F4 Insert points
F5 Geometry
F6 Technology
F7 Cancel
F8 Capture

Drilling Cycle



Selection of the cycle from the cycle group by means of the soft keys „Previous variant“ and „Next variant“.

Geometry

Z coordinate of the drilling center

Safety distance Z (Zs)

Total depth (L)

Actual drilling depth in Z



Then, please enter all necessary technological data (tool number, direction of rotation, feed rate, spindle speed).

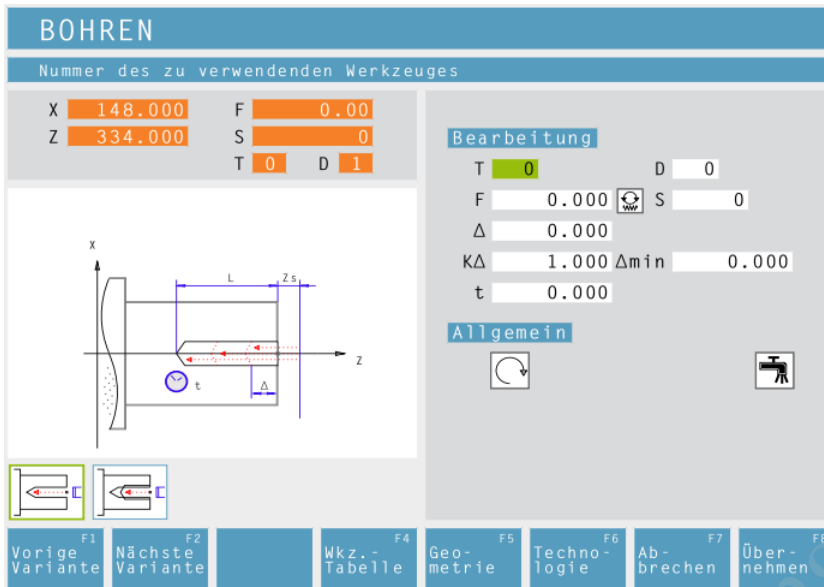

Drilling stroke for 1st cutting depth (Δ)

1st depth of a drilling operation

Reducing factor for drilling stroke ($K\Delta$)

Factor by which the subsequent drilling strokes will be reduced.

Minimum drilling stroke (Δ_{min})

Smallest cutting depth required (only for decreasing cutting depth)

Dwell time (t)

in seconds

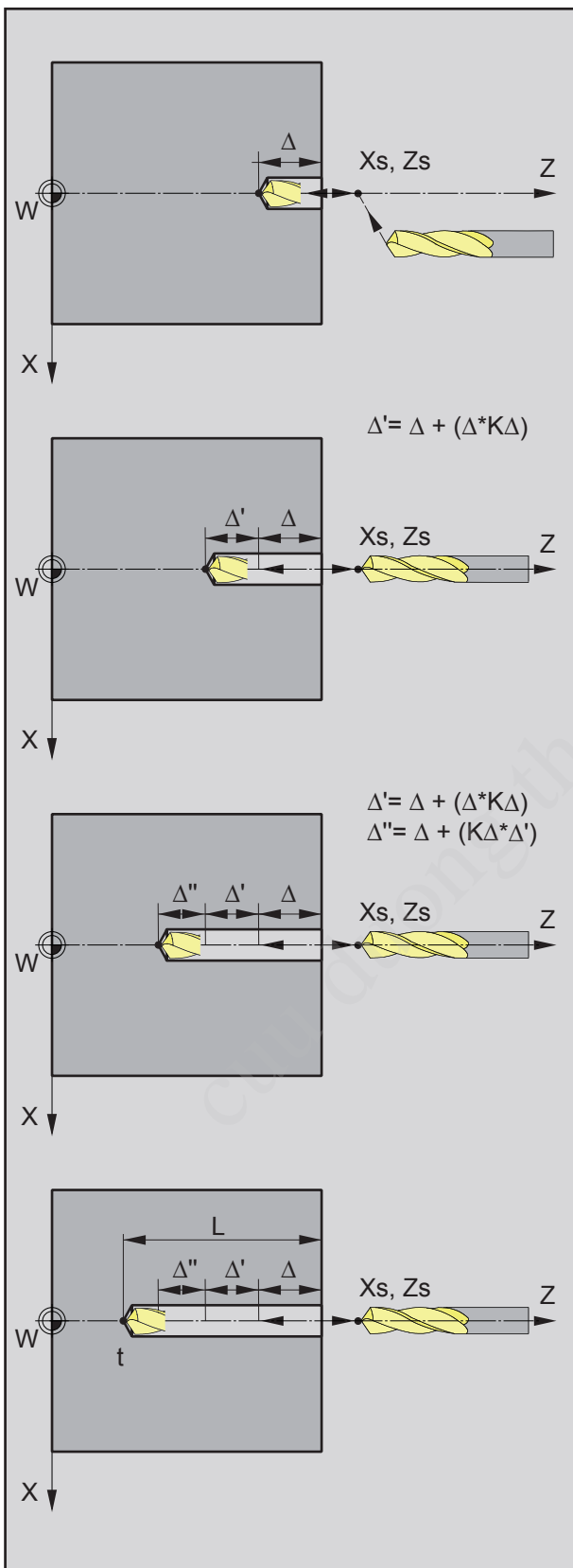

Example 2

Example 1:

Total drilling depth $L = 20$ mm,
drilling stroke $\Delta = 7$ mm, reducing factor $K\Delta = 1$

The control automatically calculates the number of the required infeeds from L and Δ :

$$20 : 7 = 2.85 \approx 3$$

This means that 3 drilling operations will be carried out until the total drilling depth of $L = 20$ mm is reached.

1. drilling depth = 7mm
2. drilling depth = 14mm
3. drilling depth = 20mm

Example 2:

Total drilling depth $L = 20$ mm,
drilling stroke $\Delta = 7$ mm, reducing factor $K\Delta = 0,8$

1. drilling depth = Δ
= 7mm
2. drilling depth = $\Delta + \Delta'$
= $\Delta + (\Delta * K\Delta)$
= $7 + (7 * 0,8)$
= 12,6mm
3. drilling depth = $\Delta + \Delta' + \Delta''$
= $\Delta + (K\Delta * (\Delta + (\Delta * K\Delta)))$
= $7 + (0,8 * 12,6)$
= 17,08mm
4. drilling depth = L
= 20.000mm

$K\Delta = 0$ or 1 : no reducing factor (drilling stroke unchanged). The total depth is divided equally. The cutting depth is automatically calculated (see example 1).

$K\Delta \neq 1$: first drilling operation with depth $=\Delta$, second drilling operation with depth $=\Delta + (\Delta * K\Delta)$, third drilling operation with depth $=\Delta + (K\Delta * (\Delta + (\Delta * K\Delta)))$ (see example 2)

Cycle Description

- 1 The tool moves in rapid traverse to the safety distance (Xs, Zs).
- 2 The tool with roughing feed then taps several tapping operations in succession. In this, the tool moves to the safety distance and then advances by the calculated infeed in each case (see example). The tool dwells (t) at the hole depth - if entered.
- 3 At the end, the tool will be pulled back to the safety distance (Xs, Zs) in rapid traverse.

cuu duong than cong . com

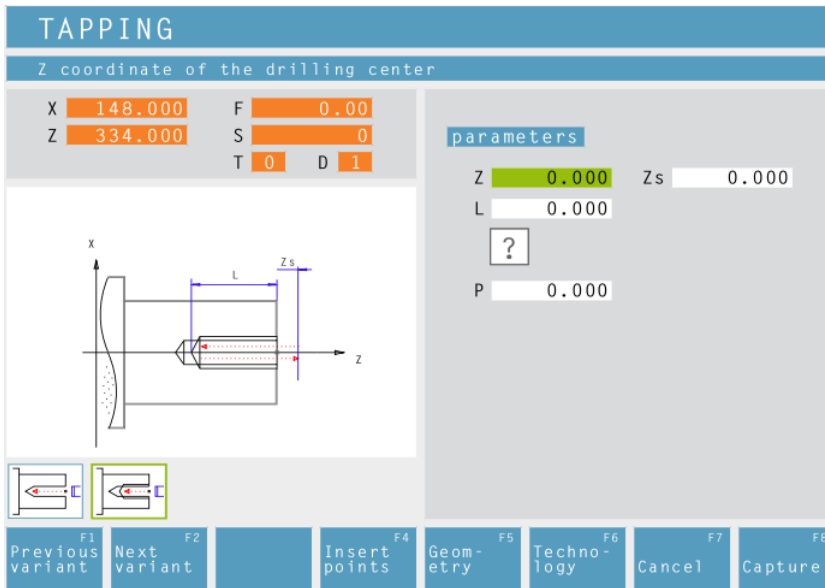

Tapping Cycle



Selection of the cycle from the cycle group by means of the soft keys „Previous variant“ and „Next variant“.



Z coordinate of the drilling center

Safety distance Z (Zs)

Total depth (L)

Actual drilling depth in Z

Thread type

You can choose among the following standardized thread types:

- Free pitch thread
- M (S.I.) Normal pitch metric thread
- M (S.I.F.) Fine pitch metric thread
- B.S.W. (W) Normal pitch Withworth thread
- B.S.F. Fine pitch Withworth thread
- U.N.C. Normal pitch unified American thread
- U.N.F. Fine pitch unified American thread

Caution:
Only tool holders with longitudinal compensation must be used for this cycle.



Note:
With the thread type „free pitch thread“ the thread pitch P and the thread depth H can be freely chosen.
With all other thread types the thread pitch P and the thread depth H will be automatically preset with standardized values after input of the thread diameter \varnothing .
In case a thread diameter is entered which is not standardized, EASY CYCLE will automatically set the next standardized diameter.



Thread pitch (P)

Thread diameter (\varnothing)

Then, please enter all necessary technological data (tool number, direction of rotation, feed rate, spindle speed).

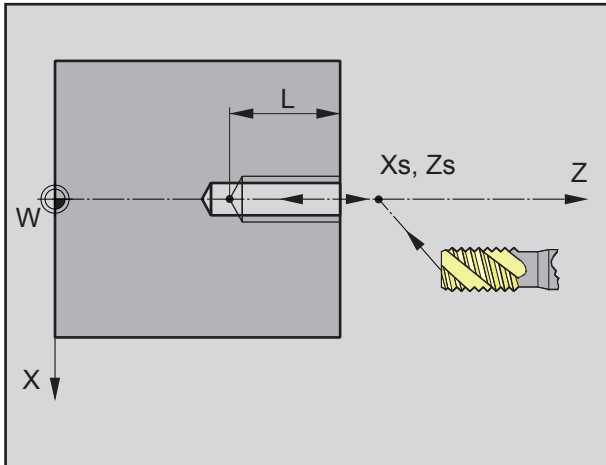

Sequence of the thread tapping

Cycle Description

- 1 The tool moves in rapid traverse to the safety distance (X_s, Z_s).
- 2 Then the tool with feed (F) taps the thread until the depth (L) is reached. The spindle stops and starts in the opposite direction.
- 3 At the end, the tool will be pulled back to the safety distance (X_s, Z_s) in rapid traverse.

cuu duong than cong . com

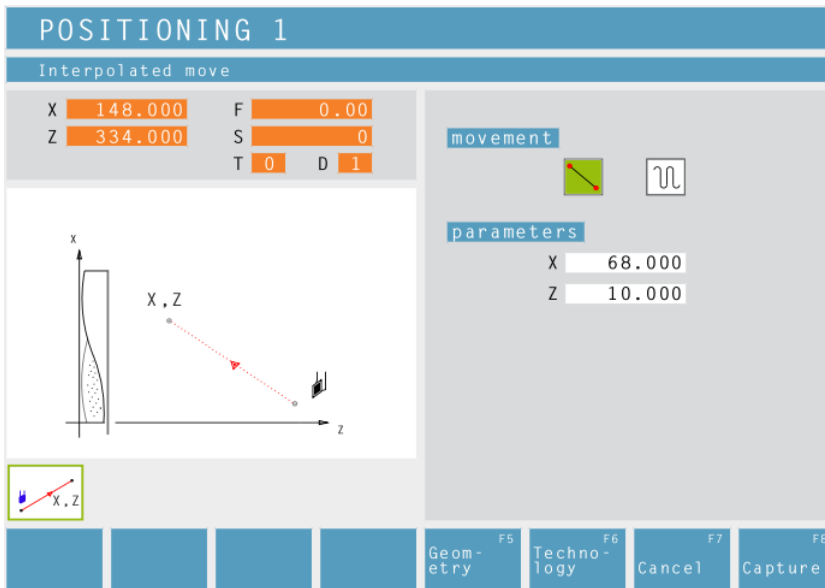

Positioning

You can traverse or position the tool in a straight way.

Use:

- to position the tool prior to the machining itself
- to traverse the tool between two cycles



The tool traverses from its current position to its target position in a straight line.

The tool traverses from its current position first in X and then in Z to its target position.

The tool traverses from its current position first in Z and then in X to its target position.

The tool moves at rapid traverse.

The tools moves at the programmed feed rate F.

Coordinates

The target position is defined by X and Z.



Then, please enter all necessary technological data (tool number, direction of rotation, feed rate, spindle speed).

cuu duong than cong . com

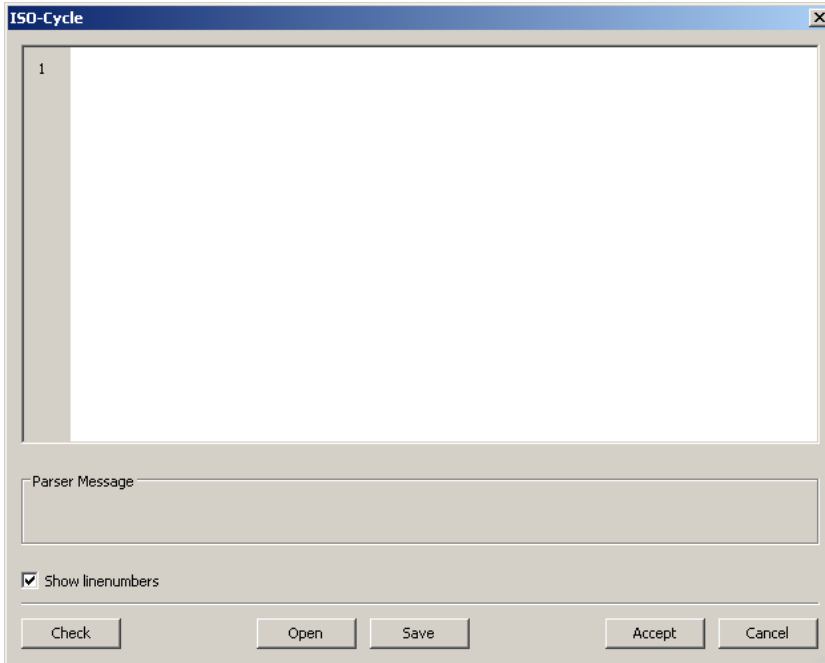

ISO edit

This cycle is used for restricted DIN/ISO code programming.

A syntax check can be performed via the "Check" button.

With the aid of the "Open" button you can embed "foreign" ISO code. The "Save" button is used to save the ISO code.

Overview of M-commands

COMMAND	MEANING
M0	Programmed stop
M1	Optional stop (program only stops at OPT. STOP)
M2	Program end
M3	Spindle ON, clockwise
M4	Spindle ON, anti-clockwise
M5	Spindle OFF
M6	Tool change
M7	Minimal lubrication ON
M8	Coolant ON
M9	Coolant OFF, minimal lubrication OFF
M20	Mandrel BACK
M21	Mandrel FORWARDS
M25	OPEN clamping device
M26	CLOSE clamping device
M30	Main program end
M71	Blow out ON
M72	Blow out OFF
M90	Manual chuck
M91	Tensile clamping device (e.g.: jaw chuck)
M92	Compressive clamping device (e.g.: collet chuck)

Overview of G-commands

COMMAND	MEANING	FORMAT
G0	Rapid feed	G0 X... Y... Z...
G1	Linear interpolation	G1 X... Y... Z...
G2	Circular interpolation, clockwise	G2 X... Y... Z... I... J... K... G2 X... Y... Z... R...
G3	Circular interpolation, anti-clockwise	G3 X... Y... Z... I... J... K... G3 X... Y... Z... R...
G4	Dwell time (in seconds)	G4 F...
G33	Thread cutting	G33 X... Y... Z... L-pitch
G40	Deselection of tool radius correction	G40
G41	Tool radius correction, left	G41
G42	Tool radius correction, right	G42
G94	Feed rate per minute	G94
G95	Feed rate per revolution	G95
G96	Constant cutting speed	G96
G97	Constant speed	G97

I, J, K circle centre point in cartesian coordinates, related to start point.
 R=+ angle smaller or equal 180°.
 R=- angle larger 180°.

Other commands

COMMAND	MEANING	FORMAT
T	Tool selection	T...
D	Cutting edge length	D...
S	Spindle speed	S...
F	Feed rate	F...

Coordinate transformation

The cycle „Coordinate transformation“ serves to zero offset the workpiece zero point (W). The following possibilities exist:

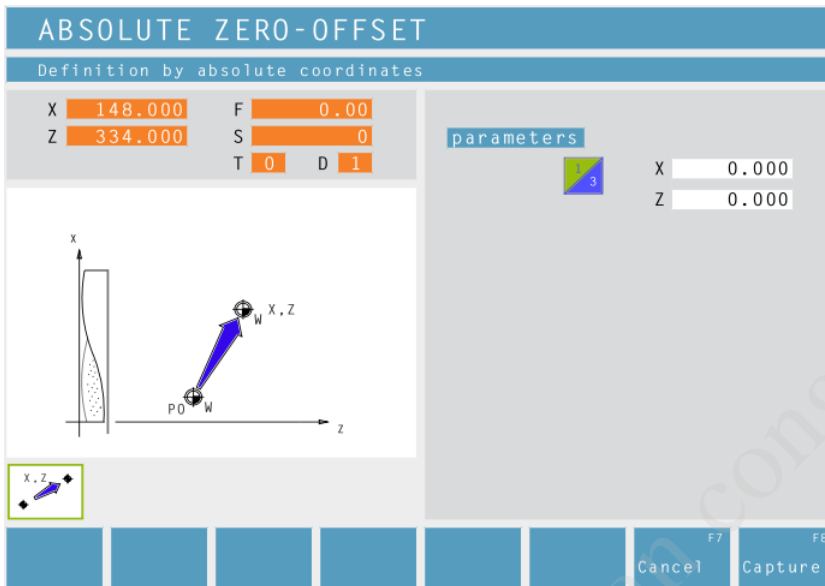

Absolute Zero-Offset



Coordinates (X, Z)
Absolute zero-offset of the workpiece zero point (W):

- X...absolute zero-offset on the X axis
- Z...absolute zero-offset on the Z axis

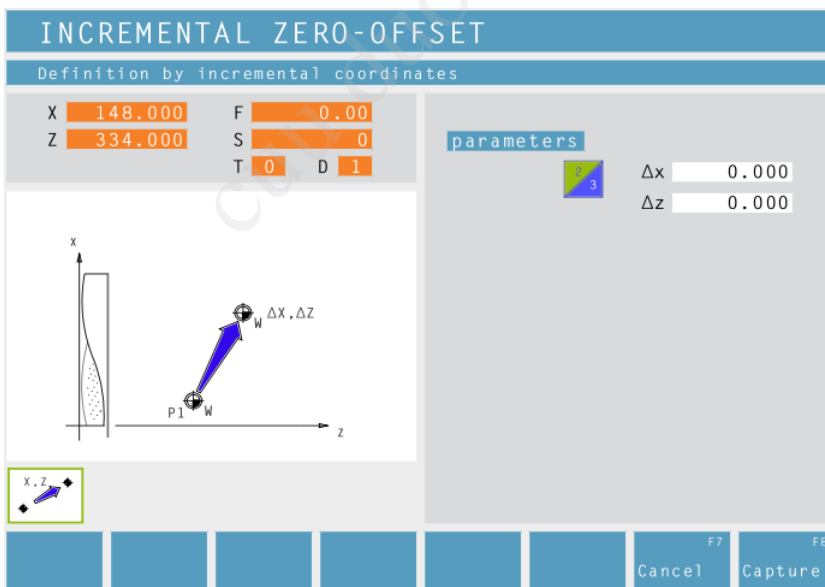

Incremental Zero-Offset



Coordinates (Δx, Δz)
Incremental zero-offset of the workpiece zero point (W):

- Δx...incremental zero-offset on the X axis
- Δz...incremental zero-offset on the Z axis

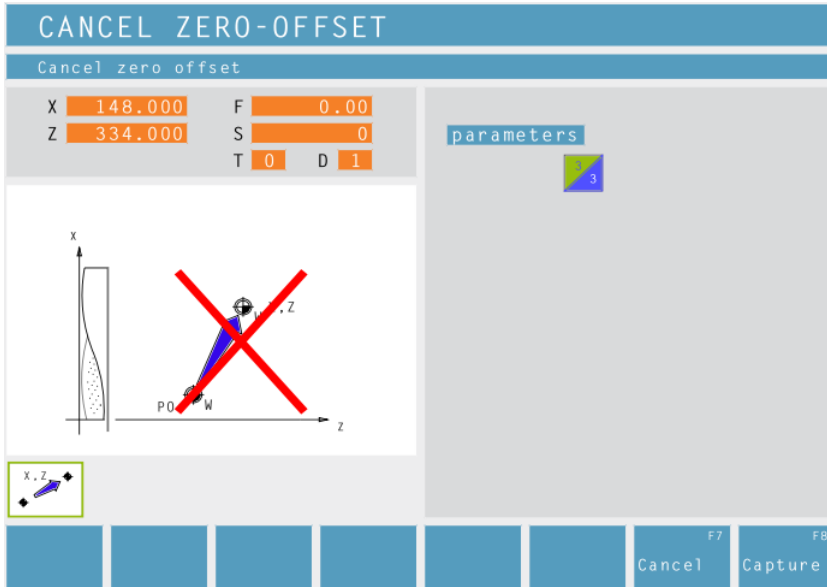

Cancel Zero-Offset



The zero offset of the workpiece zero point (W) is cancelled.

cuu duong than cong . com

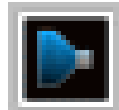

Simulation

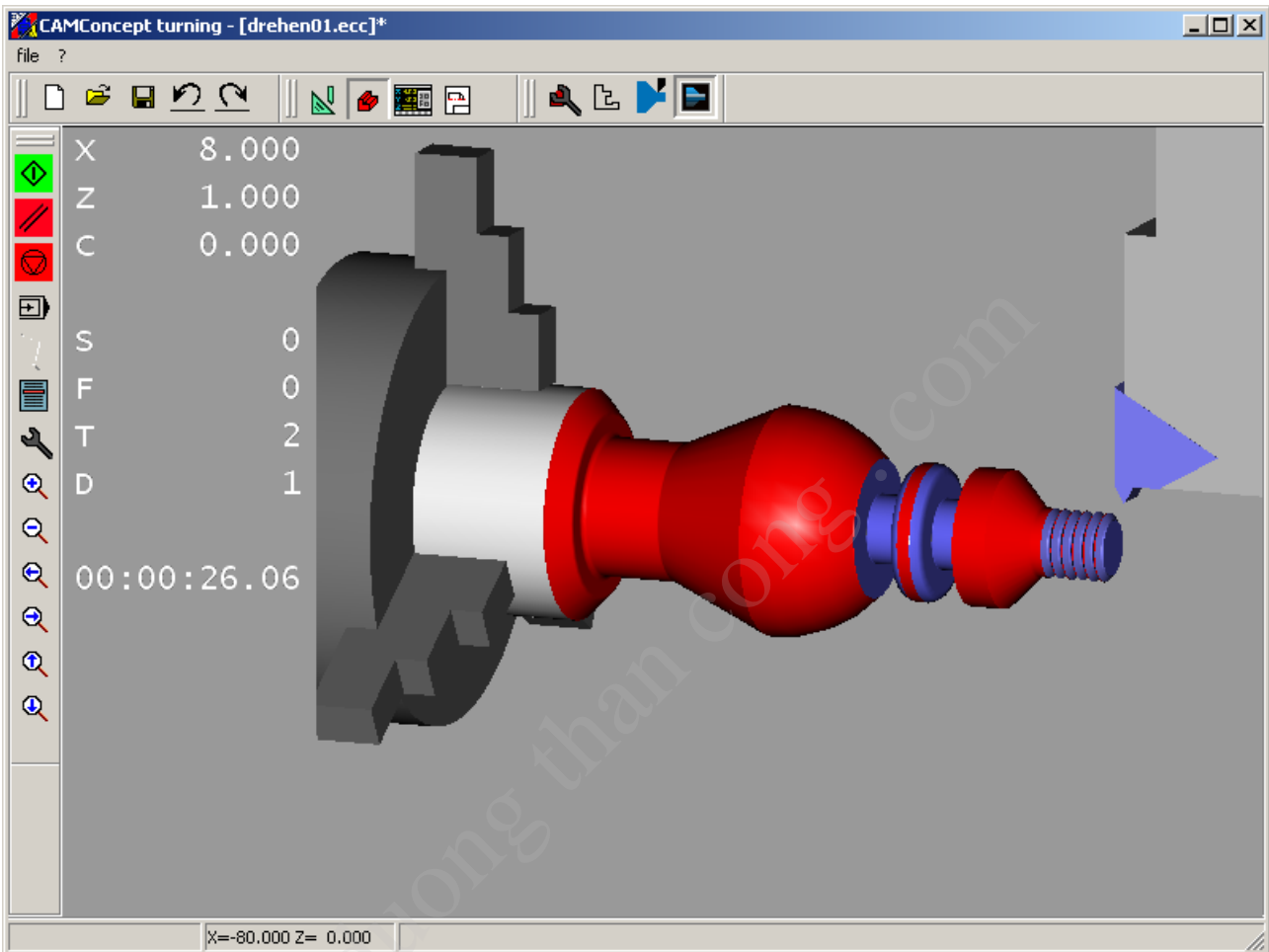

CAMConcept simulation window

The simulation window shows the machining of the workpiece.

Note:

You can modify existing tools and create new tools by means of the 3D ToolGenerator (see chapter 3D ToolGenerator).



Besides the simulation window, the current feed rates, spindle speeds, names and position values of the tool are displayed.

The machining time is displayed in hours: minutes: seconds.centiseconds.

Error messages are also displayed here, e.g. danger of collision.

**NC start**

The simulation is started with this symbol. A CAMConcept project must be open in order to be able to start the simulation. The file name of the CAMConcept project being open at the moment is displayed in the upper center of the simulation window (e.g.: flange9.ecc).

**NC reset**

With this symbol the simulation and the CNC program are aborted and they return to their initial state.

**NC stop**

With this symbol the simulation and the CNC program are stopped. The simulation can be continued by means of the symbol "NC start".

**Single block on/off**

This symbol enables to stop the simulation after every block. The simulation can be continued by means of the symbol "NC start".

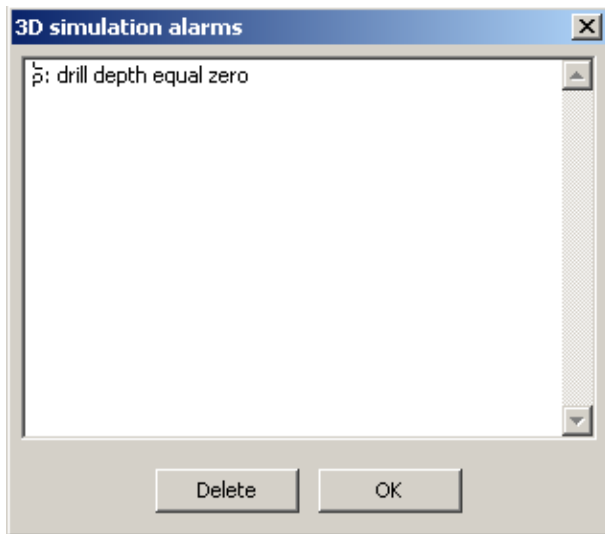

Alarms of the 3D simulation

This symbol signals that CAMConcept has detected one or several errors in the 3D simulation.

Press the symbol and the alarm window will be opened. The alarm messages are listed in the alarm window.

With "Delete" alarms are acknowledged and deleted.

With "OK" alarms are confirmed and remain in the alarm list.

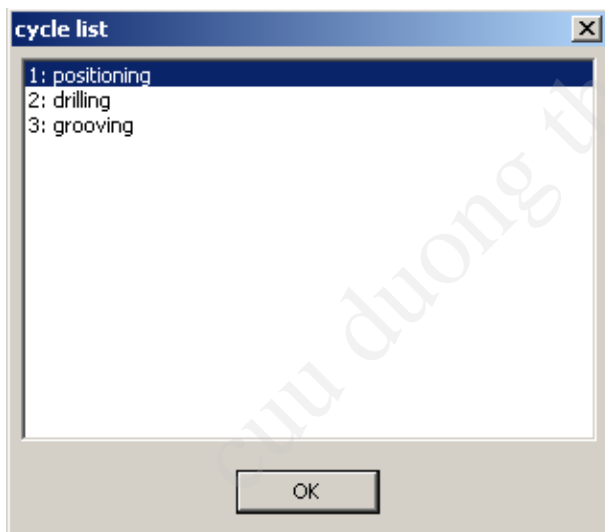

Cycle lists

After having selected the symbol, the window "cycle list" will appear. It displays all defined cycles of a project. The cycle being machined at the moment is displayed with a frame.



3D-simulation settings

After having selected the symbol, the window for the simulation properties will appear.

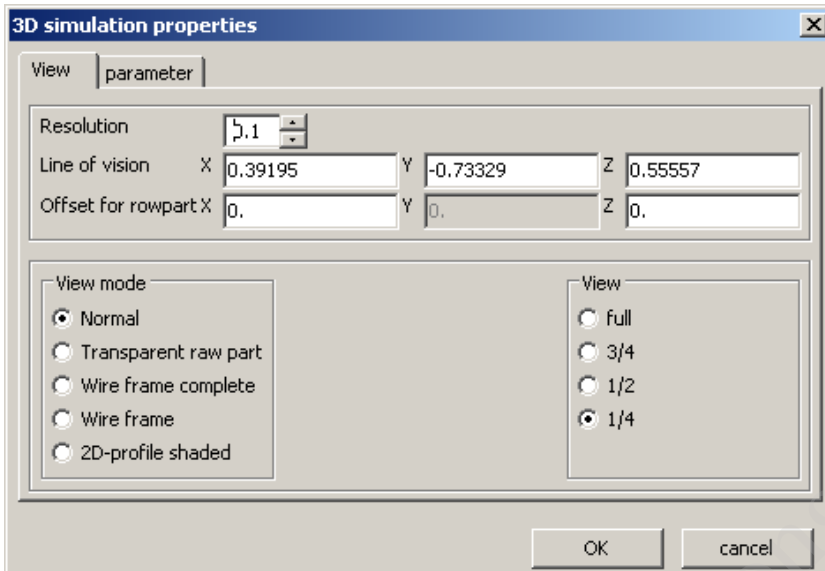

You can define the following settings in the register card "View".

Global resolution:

You can enter values from 0.01 to 0.3. The higher the resolution, the more precise is the structure of the 3D image.

Viewing direction:

With the viewing direction the initial view on the unmachined part can be pre-set. However, the viewing direction can always be changed during simulation by means of the mouse as well.

Representation type:

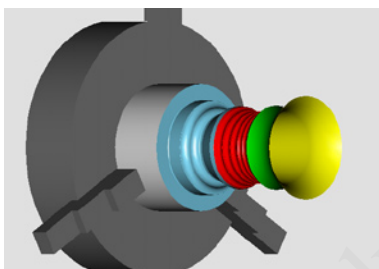

• Normal representation

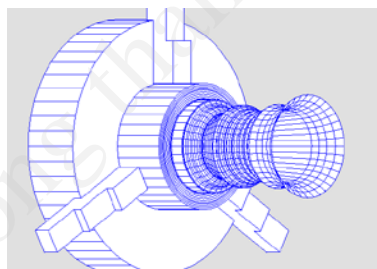

• Wire model, complete

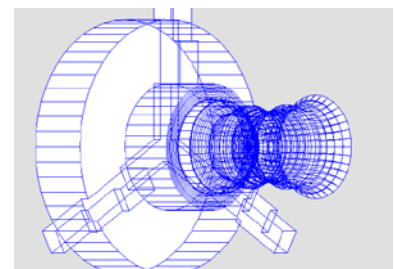

• Wire model

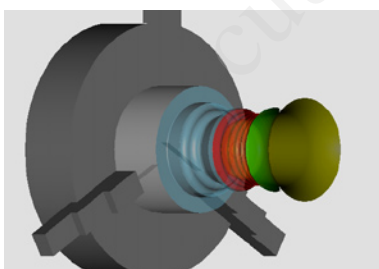

• Transparent unmachined part



• 2D profile, shaded

View:

The section view enables to observe normally hidden sequences. You may choose between the following views:

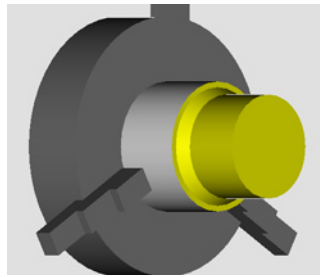

full 3D-view

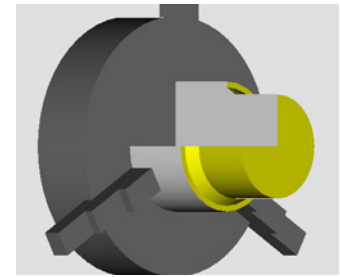

3/4 view

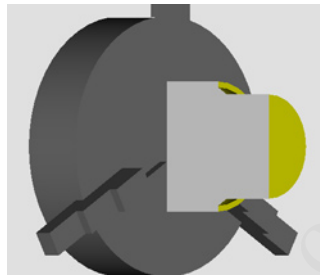

1/2 view

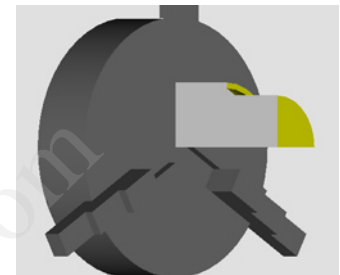

1/4 view

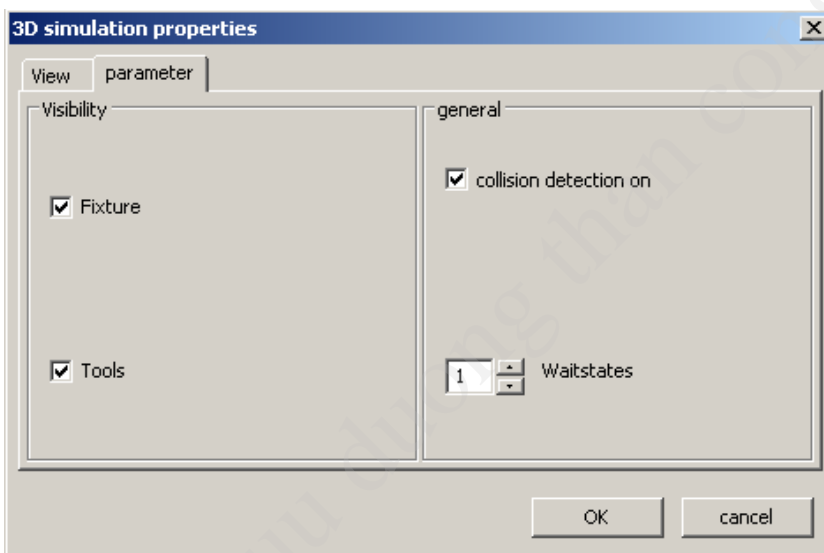

You can define the following settings in the register card "Parameter":

Visibility:

- clamping device visible/ invisible
- tailstock visible/ invisible
- tools visible/ invisible

General:

- collision detection on/off
- waiting cycles 0-99

Collision detection:

During collision detection the following situations are monitored:

- Contacts between tool and clamping device. When the display of the clamping device is switched off, collisions of clamping devices are not monitored.
- Contacts of non-cutting tool parts with the workpiece or the clamping device.

In case of a collision the collision type will be displayed and the simulation will be aborted.

Waiting cycles

The simulation can be slowed down by means of waiting cycles. A waiting cycle is the freely definable time that has to pass between two tool movements. The waiting cycle is defined in values between 0 and 99.

The higher the value of the waiting cycle, the longer lasts the simulation.

Zoom commands for the simulation

The navigation bar enables to zoom and shift the simulation image.



Zoom in

After the symbol has been selected, the view is zoomed in by one step.



Zoom out

After the symbol has been selected, the view is zoomed out by one step.



To zoom the simulation image in or out in an infinitely variable way, press "Ctrl" + the left mouse button + mouse movement upwards or downwards.



Shift

After selection of the symbol the view is shifted step by step.

Press the right mouse button + mouse movement in the required direction to shift the simulation image in an infinitely variable way.



Rotate

At any time you can rotate the simulation image in one plane as required by pressing and holding the left mouse button. For movements around the Z axis press "Shift" + left mouse button + mouse movement to the right or to the left.



Tool modelling with the 3D-Tool Generator

With the 3D-ToolGenerator you can modify existing tools and create new tools.

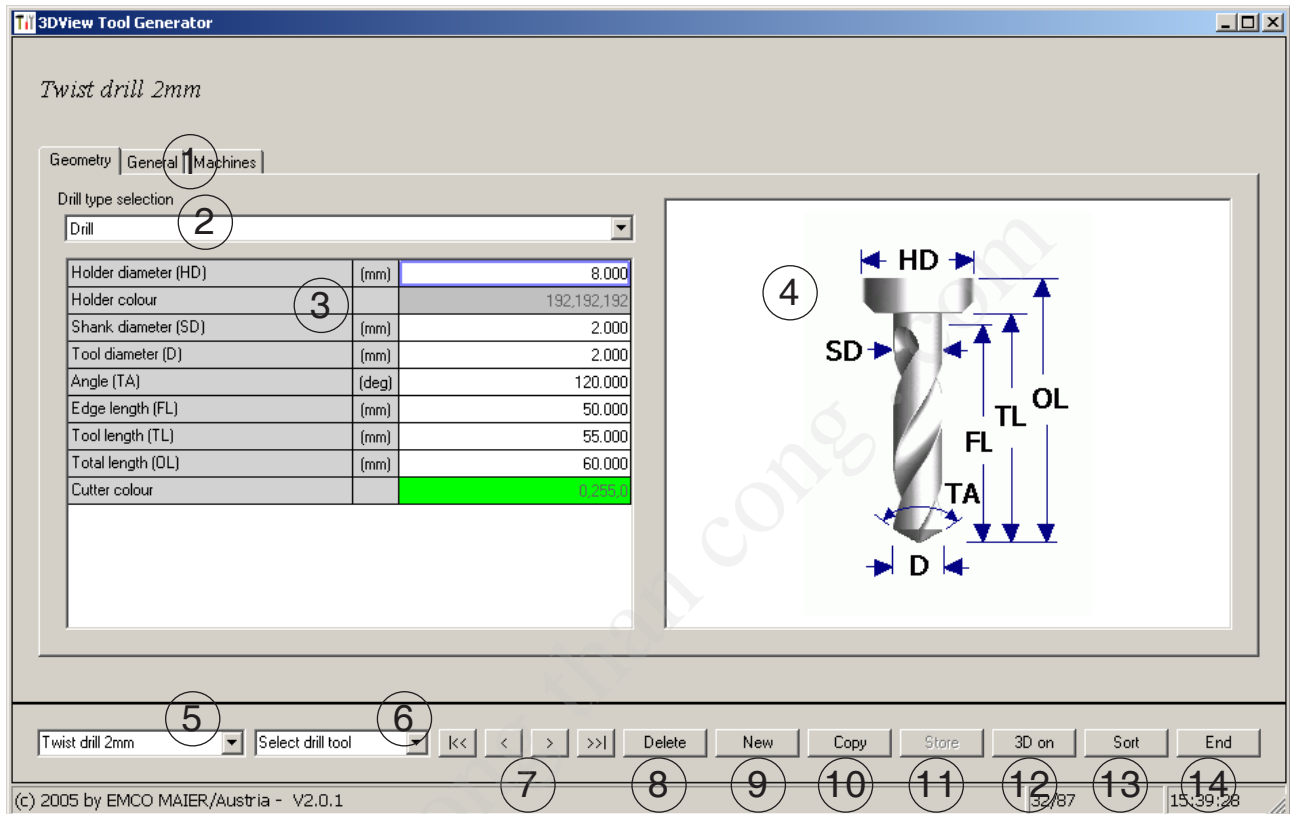

1 Register cards for "Geometry", "General" and "Machines" for drilling and milling tools and "Tip", "Holder", "General" and "Machines" for turning tools.

2 Selection of tool types

3 This window enables the input of tool dimensions.

4 Graphical support for the tool dimensioning

5 Choice of tools for the selected tool type

6 Choice of tool types (here: only drill)

"Turning tool", "Milling tool" and "Drilling tool"

reduce the tool choice to the respective type (here: only drilling tools are listed).

"All" does not reduce the tool choice.

7 Buttons for quickly browsing through the tools

go to first tool in the group

go to last tool in the group

go forward in the list by one tool

go back in the list by one tool

8 Button to delete tools

9 Button to create new tools

10 Button to copy tools

11 Button to save changes

12 Button for 3D visualization

13 Button to sort tools

14 Button to terminate the 3DView tool generator

Generating a new tool

- Set the selection for tool types to "Selection all".
- Press the button to generate new tools.
- Select the tool name, the tool type and the measurement system.

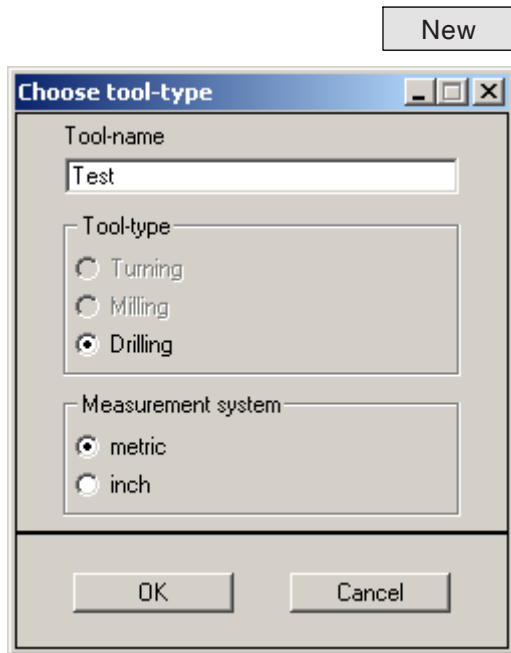

OK

- Confirm the entries with "OK".

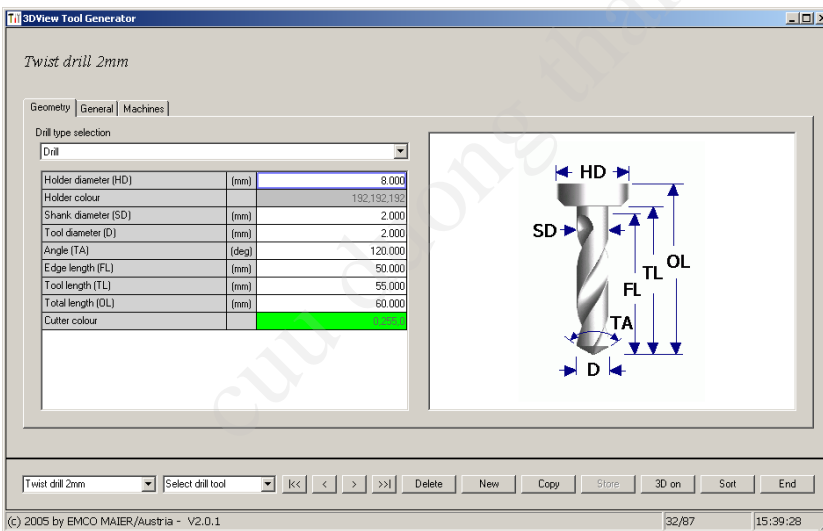

Store

- Define all tool dimensions.
- Define all tool colours (see "select tool colour").
- Confirm the entries with "Store".

Copying a tool

- Call the tool you wish to copy.
- Press the button to copy tools.
- Enter the new tool name.
- Confirm the inputs with "Save".

Copy

Changing an existing tool

- Call the tool you wish to change.
- Change the values.
- Confirm the entries with "Store".

Store

Selecting a tool colour

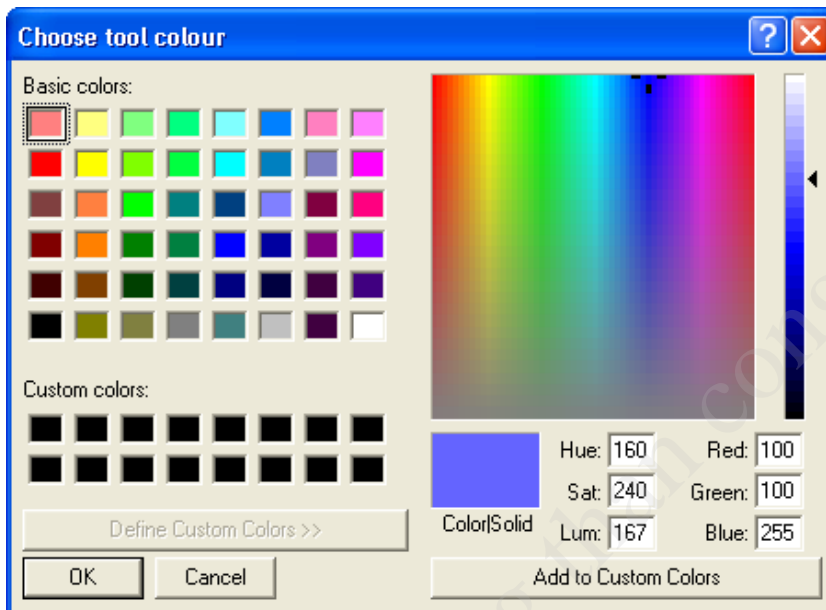

- Make a double click with the mouse pointer in the coloured box of the tool colour. The window "Select tool colour" will appear.
- Select the required colour.

OK

- Confirm the entries with "OK".

Visualizing a tool

- Press the button for 3D visualization.

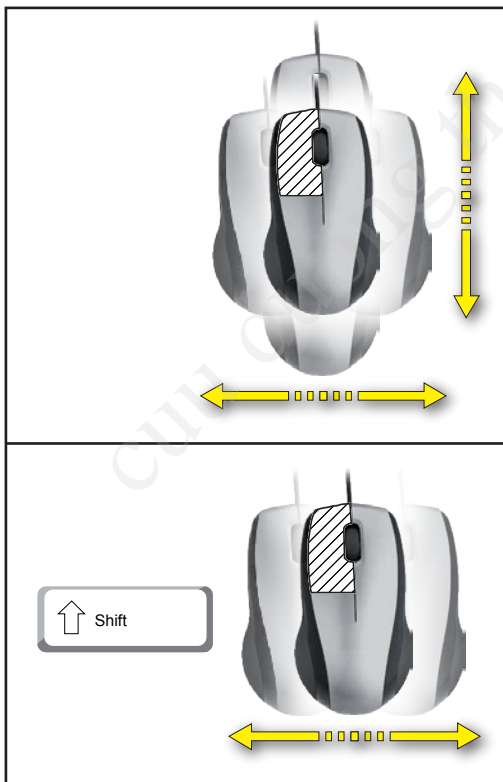
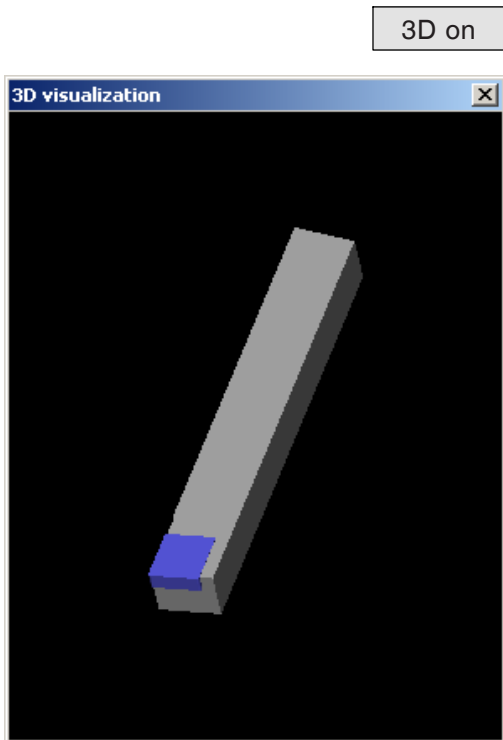

Rotating image

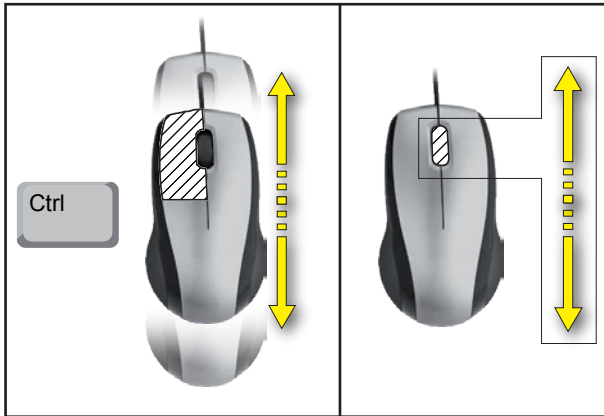

Zooming

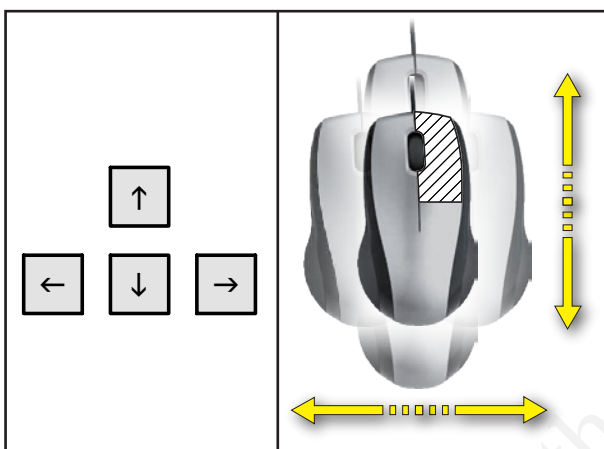

Shifting

Sorting function

The sorting sequence makes it possible to display the tools being sorted according to tool types. Every time the sorting sequence is changed, the selection for tools will be updated.



- Press the button for sorting.

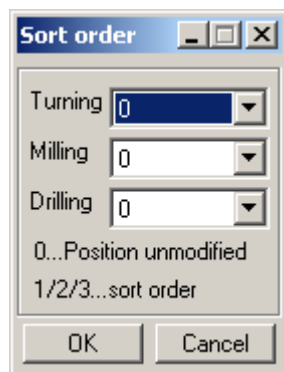

- Define new sorting sequence.



- Confirm the entries with "OK".

F: NC commands

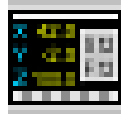

NC mode

By clicking on the "NC" switchover icon all of the NC command icons are activated. The NC mode remains active until it is deselected with CAD, CAM or AV.

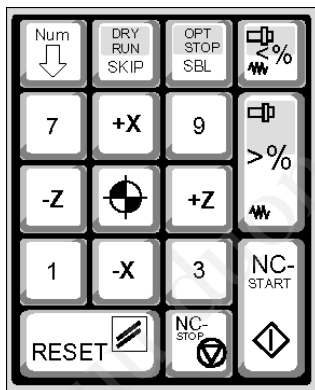

The machine functions in the numerical keypad are only active if NUM Lock is not enabled. You can use both the CAMConcept icons and the keys on the numerical keypad to select functions.

Key functions in the numerical keypad

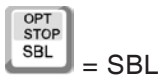

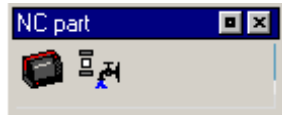

NC part



Working through the NC program

Screen layout for an NC part

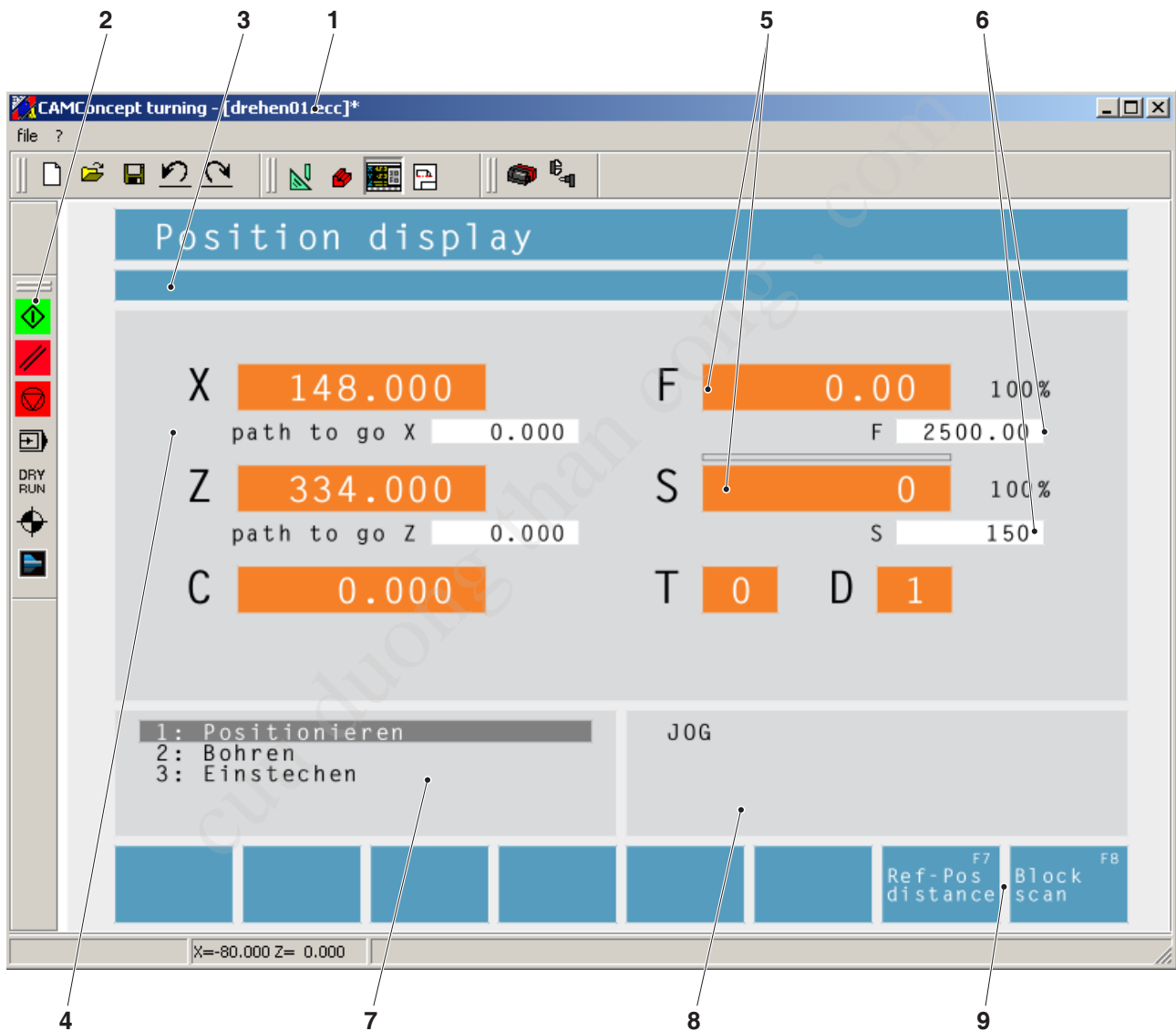

- 1 Project name
- 2 Program execution commands
- 3 Alarm and message bar
- 4 NC position displays; technology data;
- 5 Display showing the current value for feed rate or speed
- 6 Display showing the programmed value for feed rate or speed

- 7 Cycle list
The defined cycles of a project are displayed here. The cycle currently being executed is shown with a grey background.
- 8 Status indication; operating mode display;
- 9 Softkeys for switching between the reference position display and the remaining path display, or for setting the block scan



NC start

This icon is used to switch from "JOG" mode to "AUTO" mode and start the NC program run for the selected program.



NC reset

This icon is used to switch from "AUTO" mode to "JOG" mode and abort the NC program run and return to the initial state.



NC stop

This icon is used to stop the NC program run. The simulation can be continued with the "NC start" icon. In the intermediate stop position you can perform various manual changes (e.g. with the periphery commands).



Single block ON/OFF

This icon is used to stop the NC program run after every block. The NC program run can be continued with the "NC start" icon each time.

If single block is switched on the text "SBL" (= Single Block) appears in the simulation window.



Dry run

This icon is used to set the status "Dry Run" (= test run). On starting of the NC program the main spindle is not switched on and the carriages are moved with a fixed feed speed.

A dry run must only be performed without a work-piece.

If dry run is switched on the text "DRY" appears in the simulation window.



Machine referencing

This icon is used to run the machine to its reference point.

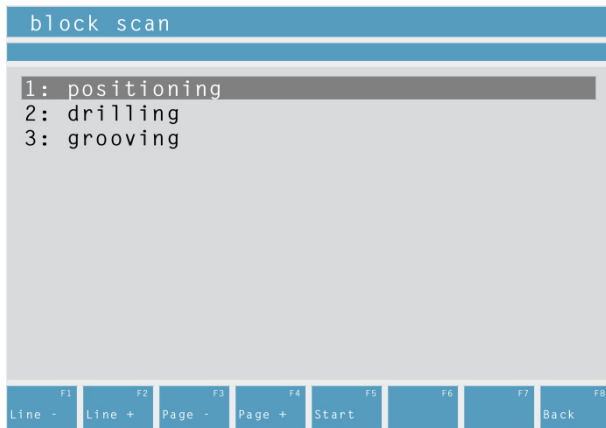
Block
scanComm.
adv.
Start

Block scan

With the "Block scan" function, cycles can be skipped when running the program.

Skipping cycles with the "Block scan" function

- Press the softkey.
- Use the cursor keys to select the cycle at which you wish the NC program to resume.

- Press the softkey. Wait until CAMConcept has calculated the remaining program. Do not press "NC-Start" until CAMConcept asks you to do so in the status bar. The skipped cycles are not executed.

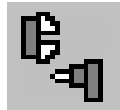

Periphery

The task of the periphery functions is to control the required NC machine accessories.

The scope of displayed periphery functions depends on the installation. Functions which are not available are shown with a grey background.



Spindle anti-clockwise

This icon is used to switch on the main spindle anti-clockwise.



Spindle stop

This icon is used to switch off the main spindle.



Spindle clockwise

This icon is used to switch on the main spindle clockwise.



Open / close clamping device

This icon is used to open or close the clamping device.

Please note that the clamping device can only be opened with the door open.

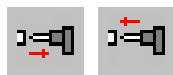

Mandrel forwards / back

These icons are used to move the mandrel forwards or backwards.



Blowing-out device ON/OFF

This icon is used to switch the blowing-out device on for 3 seconds.

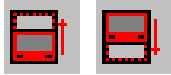

Open / close automatic door

These icons are used to open or close the machine door.

Please note that the clamping device can only be opened with the door open.



Coolant ON/OFF

This icon is used to switch the coolant pump on or off.



Next tool

This icon is used to advance the tool drum by 1 tool. This function can also be performed by pressing the key combination ALT + K.

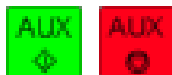

Auxiliary drives ON/OFF

These icons are used to switch the auxiliary drives on or off.

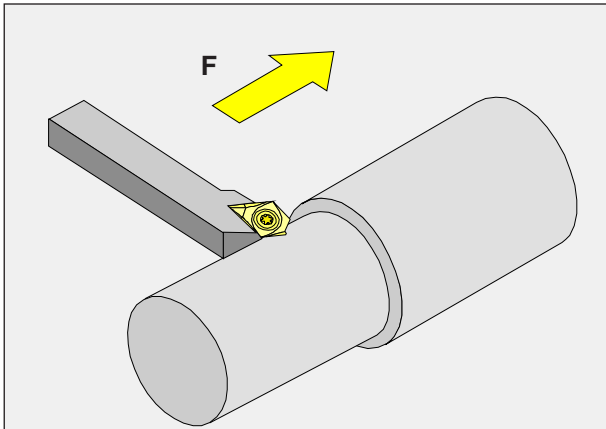

Feed rate F [mm/min]

The feed rate F is the speed in mm/min (feet/min) at which the centre of the tool moves on its path. The maximum feed rate can vary for each of the machine axes and is defined by machine parameters.

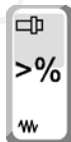

Input

- Use the key to select the feed rate input field.
- Enter the required feed rate.
- Press the "Enter" key. The desired value is automatically entered in the display for the programmed value.

Rapid feed

For the rapid feed enter F99999. When the data are adopted (by pressing "Enter") the value is then corrected to the rapid feed rate of the current machine.

Feed control

The feed rate value F you have programmed corresponds to 100%. With the aid of these buttons or with the "Feed override" function you can change the set feed rate F by a percentage factor.

Adjustment range:

0% to 120% of the programmed feed rate. Only the changed percentage - but not the resulting effective value - is displayed. A level of 100% cannot be exceeded in rapid feed.

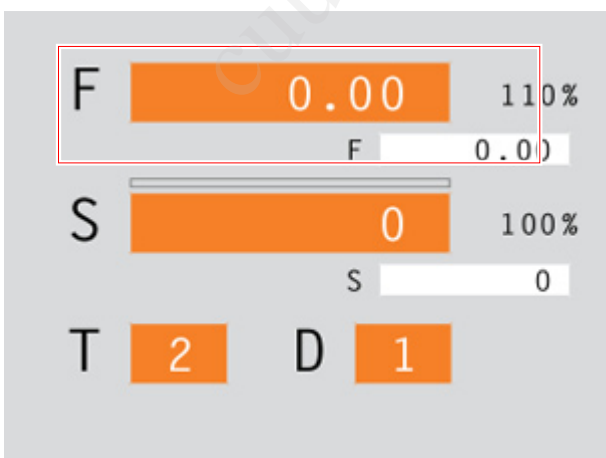

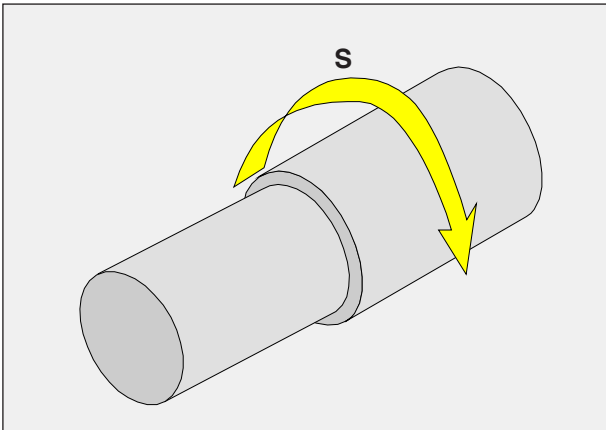

Spindle speed S [rpm]

The spindle speed S is entered as revolutions-per-minute (rpm).

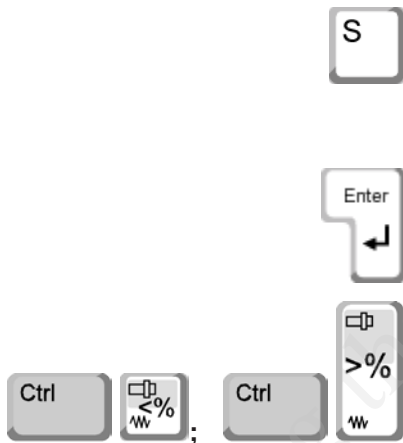

Input

- Use the key to select the spindle speed input field.
- Enter the desired speed.
- Press the "Enter" key. The desired value is automatically entered in the display for the programmed value.

Spindle speed correction

The spindle speed S you have programmed corresponds to 100%. With the aid of these key combinations or the "Spindle speed override" function you can change the set spindle speed S by a percentage factor.

Adjustment range:

50% to 120% of the programmed spindle speed. Only the changed percentage - but not the resulting effective value - is displayed.



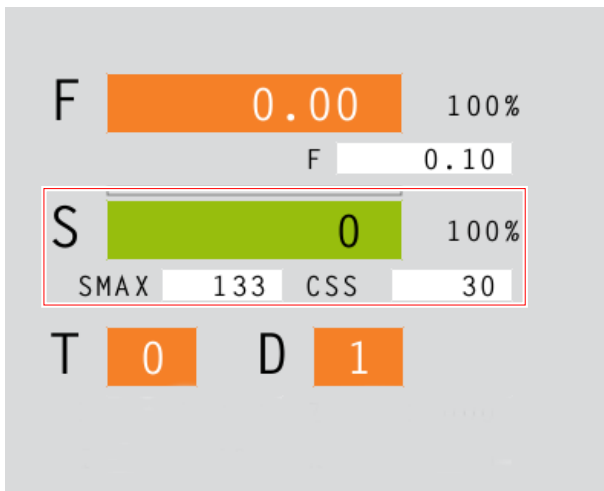

Constant cutting speed CSS [m/min]

The constant cutting speed CSS is specified in (m/min) or (inches/min).

If constant cutting speed is activated the spindle speed is automatically adjusted according to the workpiece diameter so that the cutting speed S (in m/min or inches/min) remains constant at the cutting edge of the tool. This produces a more consistent turning pattern and therefore better surface quality.

If a workpiece with a large diameter is machined, we recommend specifying a maximum spindle speed limit. This will prevent prohibited high speeds at small diameters.



- Use the key to select the spindle speed input field.
- Enter the desired speed.



Activating CSS

- Activate the constant cutting speed in the CAM mode for the relevant cycle. The programmed spindle speed S is automatically converted to the constant cutting speed CSS.
- Enter the required constant cutting speed.
- Enter the maximum spindle speed limit Smax.



Deactivating CSS

- Press the CSS button again to deactivate the constant cutting speed. The programmed constant cutting speed CSS is automatically converted to the spindle speed S.



20

Position
approach

Traversing coordinate axes

Example: Traverse the X-axis to position 20

- Use the key to select the input field for the axis which is to be traversed.
- Enter the required coordinate value.
- Press the softkey to traverse the axis at the set feed rate.



Reset

Setting / resetting a reference point

Setting a reference point

- Use the key to select the input field for the desired axis.
- Enter the required reference value.
- Press the "Enter" key.
- CAMConcept opens a dialog box. Press "Enter" to confirm this query.

Resetting a reference point

- Use the key to select the input field for the desired axis.
- Press the softkey to reset a previously set reference point to the zero point of the machine.

Loading a new tool



3



2

Example: Select tool 3 with cutting edge 2

- Use the key to select the tool number input field.
- Enter the number of the required tool (3).
- Press "Enter" to load the tool.
- Use the key to select the cutting edge number input field.
- Enter the number of the required cutting edge (2).
- Press "Enter" so that CAMConcept registers the chosen cutting edge 2.

Note:

With the cutting edge number 0 no tool movement is provided.

G: Operations scheduling

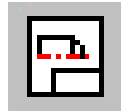

Operations scheduling mode

The AV (= operations scheduling) command symbols are activated by clicking on the shift symbol "AV".

The operations scheduling mode will remain active until it is deselected with CAD, CAM or NC.

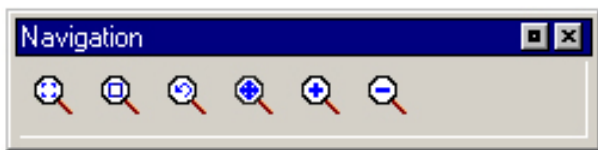

The zoom commands are described in chapter B.

cuu duong than cong . com

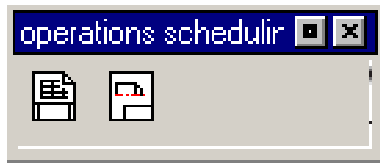

Operations scheduling



Print tool table

After having selected the symbol, you can define the entries for the text field in the input window.

date:	name:	description:
06/17/09	Mr. Clark	plate

Input window for the text field



Print plans

After having selected the symbol, you can specify the print area with the mouse. In the input window you can edit the engineering drawing block and also set the scale.

scale:	date:	name:	description:
1:10	06/17/09	Mr. Clark	plate

Input window print plans



Plane setting

After having selected the symbol, you can make the planes either visible or invisible by switching in the select window.

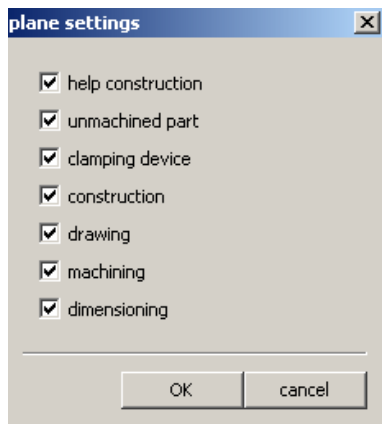

Level settings window

cuu duong than cong . com

cuu duong than cong . com

H: Alarms and Messages

Machine Alarms 6000 - 7999

These alarms will be triggered by the machines. There are different alarms for the different machines.

The alarms 6000 - 6999 normally must be confirmed with RESET. The alarms 7000 - 7999 are messages which normally will disappear when the releasing situation is finished.

PC MILL 50 / 55 / 100 / 105 / 125 / 155 Concept MILL 55 / 105 / 155

6000: EMERGENCY OFF

The EMERGENCY OFF key was pressed. Remove the endangering situation and restart machine and software.

6001: PLC-CYCLE TIME EXCEEDING

Contact EMCO Service.

6002: PLC - NO PROGRAM CHARGED

Contact EMCO Service.

6003: PLC - NO DATA UNIT

Contact EMCO Service.

6004: PLC - RAM MEMORY FAILURE

Contact EMCO Service.

6005: OVERHEAT BRAKEMODUL

Main drive was braked too often, large changes of speed within a short time. E4.2 active

6006: OVERLOAD BRAKE RESISTOR

see 6005

6007: SAFETY CIRCUIT FAULT

Axis and main drive contactor with machine switched off not disabled. Contactor got stuck or contact error. E4.7 was not active during switch-on.

6009: SAFETY CIRCUIT FAULT

Defective step motor system.

A running CNC program will be interrupted, the auxiliary drives will be stopped, the reference position will be lost.

Contact EMCO Service.

6010: DRIVE X-AXIS NOT READY

The step motor board is defective or too hot, a fuse or cabling is defective.

A running program will be stopped, the auxiliary drives will be switched off, the reference position will be lost.

Check fuses or contact EMCO service.

6011: DRIVE Y-AXIS NOT READY

see alarm 6010.

6012: DRIVE Z-AXIS NOT READY

see alarm 6010.

6013: MAIN DRIVE NOT READY

Main drive power supply defective, main drive too hot, fuse defective.

A running program will be stopped, the auxiliary drives will be switched off.

Check fuses or contact EMCO Service.

6014: NO MAIN SPINDLE SPEED

This will be released, when the spindle speed is lower than 20 rpm because of overload.

Alter cutting data (feed, infeed, spindle speed).

The CNC program will be aborted, the auxiliary drives will be stopped.

6019: VICE TIME EXCEED

The electric vice has not reached a stop position within 30 seconds.

The control or the clamping device board are defective, the vice is stuck. Adjust the proximity switches of the stop position.

6020: VICE FAILURE

When the electric vice is closed, the signal "clamping device clamped" of the clamping device board has failed.

The control, the clamping device board or the wiring are defective.

6022: CLAMPING DEVICE BOARD DEFECTIVE

The signal "clamping device clamped" is constantly released, although no command has been given.

Replace the board.

6024: MACHINE DOOR OPEN

The door was opened while a machine movement. The program will be aborted.

6027: DOOR LIMIT SWITCH DEFECTIVE

The limit switch of the automatic door is displaced, defective, wrong cabled.

Contact EMCO service.

6028: DOOR TIMEOUT

The automatic door sticks, the pressured air supply is insufficient, the limit switch is displaced.

Check door, pressured air supply, limit switch or contact EMCO service.

6030: NO PART CLAMPED

No workpiece inserted, vice cheek displaced, control cam displaced, hardware defective.

Adjust or contact EMCO service.

6040: TOOL TURRET INDEX FAILURE

After WZW procedure drum pressed down by Z-axis. Spindle position wrong or mechanical defect. E4.3=0 in lower state

6041: TOOL CHANGE TIMEOUT

Tool drum sticks (collision?), main drive not ready, fuse defective, hardware defective.

A running CNC program will be stopped.

Check for collisions, check fuses or contact EMCO service.

6043-6046: TOOL DISK POSITION FAULT

Position error of main drive, error of position supervising (inductive proximity switch defective or disadjusted, drum allowance), fuse defective, hardware defective.

The Z axis could have been slipped out of the toothing while the machine was switched off.

A running CNC program will be stopped.

Contact EMCO service.

6047: TOOL DISK UNLOCKED

Tool drum turned out of locked position, inductive proximity switch defective or disadjusted, fuse defective, hardware defective.

A running CNC program will be interrupted.

Contact EMCO service.

When the tool drum is turned out of locked position (no defect), act as following:

Turn the drum into locking position manually

Change into MANUAL (JOG) mode.

Turn the key switch. Traverse the Z slide upwards, until the alarm disappears.

6048: DIVIDING TIME EXCEEDED

Dividing head sticks, insufficient pressured air supply, hardware defective.

Check for collision, check pressured air supply or contact EMCO service.

6049: INTERLOCKING TIME EXCEEDED

see alarm 6048

6050: M25 AT RUNNING MAIN SPINDLE

Cause: Programming mistake in NC program.

A running program will be aborted.

The auxilliary drives will be switched off.

Remedy: Correct NC program

6064: DOOR AUTOMATIC NOT READY

Cause: pressure failure automatic door
automatic door sticks mechanically
limit switch for open end position defective
security print circuits defect
cabling defective
fuses defective

A running program will be aborted.

The auxilliary drives will be switched off.

Remedy: service automatic door

6069: CLAMPING FOR TANI NOT OPEN

When opening the clamping pressure switch does not fall within 400ms. Pressure switch defective or mechanical problem. E22.3

6070: PRESSURE SWITCH FOR TANI MISSING

When closing the clamping pressure switch does not respond. No compressed air or mechanical problem. E22.3

6071: DIVIDING DEVICE NOT READY

Servo Ready Signal from frequency converter missing. Excess temperature drive TANI or frequency converter not ready for operation.

6072: VICE NOT READY

Attempt to start the spindle with an open vice or without clamped workpiece.

Vice sticks mechanically, insufficient compressed air supply, compressed air switch defective, fuse defective, hardware defective.

Check the fuses or contact EMCO service.

6073: DIVIDING DEVICE NOT READY

Cause: locking switch defective
cabling defective
fuses defective

A running program will be aborted.

The auxilliary drives will be switched off.

Remedy: service automatic dividing device
lock the dividing device

6074: DIVIDING TIME EXCEEDED

Cause: dividing device sticks mechanically
locking switch defective
cabling defective
fuses defective
insufficient compressed-air supply.

A running program will be aborted.

The auxilliary drives will be switched off.

Remedy: Check for collision, check the compressed-air supply or contact the EMCO service.

6075: M27 AT RUNNING MAIN SPINDLE

Cause: Programming mistake in NC program.

A running program will be aborted.

The auxilliary drives will be switched off.

Remedy: Correct NC program

7000: INVALID TOOL NUMBER PROGRAMMED

The tool position was programmed larger than 10.

The CNC program will be stopped.

Interrupt program with RESET and correct the program.

7001: NO M6 PROGRAMMED

For an automatic tool change you also have to program a M6 after the T word.

7007: FEED STOP!

The axes have been stopped by the robotics interface (robotics entry FEEDHOLD).

7016: SWITCH ON AUXILIARY DRIVES

The auxiliary drives are off. Press the AUX ON key for at least 0.5 sec. (to avoid accidentally switching on) to switch on the auxiliary drives.

7017: REFERENCE MACHINE

Approach the reference point.

When the reference point is not active, manual movements are possible only with key switch at position "setting operation".

7018: TURN KEY SWITCH

With NC-Start the key switch was in position "setting operation".

NC-Start is locked.

Turn the key switch in the position "automatic" to run a program.

7020: SPECIAL OPERATION MODE ACTIVE

Special operation mode: The machine door is opened, the auxiliary drives are switched on, the key switch is in position "setting operation" and the consent key is pressed.

Manual traversing the axes is possible with open door. Swivelling the tool turret is not possible with open door. Running a CNC program is possible only with standing spindle (DRYRUN) and SINGLE block operation.

For safety: If the consent key is pressed for more than 40 sec. the function of this key is interrupted, the consent key must be released and pressed again.

7021: INITIALIZE TOOL TURRET

The tool turret operating was interrupted.

No traversing operation is possible.

Press tool turret key in JOG operation. Message occurs after alarm 6040.

7022: INITIALIZE TOOL TURRET !

see 7021

7023: WAITING TIME MAIN DRIVE!

The LENZE frequency converter has to be separated from the mains supply for at least 20 seconds before you are allowed to switch it on again. This message will appear when the door is quickly opened/ closed (under 20 seconds).

7038: LUBRICATION SYSTEM FAULT

The pressure switch is defective or gagged.

NC-Start is locked. This can be reset only by switching off and on the machine.

Contact EMCO service.

7039: LUBRICATION SYSTEM FAULT

Not enough lubricant, the pressure switch is defective.

NC-Start is locked.

Check the lubricant and lubricate manually or contact EMCO service.

7040: MACHINE DOOR OPEN

The main drive can not be switched on and NC-Start can not be activated (except special operation mode)

Close the machine to run a program.

7042: INITIALIZE MACHINE DOOR

Every movement and NC-Start are locked.

Open and close the machine door to initialize the safety circuits.

7043: PIECE COUNT REACHED

A predetermined number of program runs was reached. NC-Start is locked. Reset the counter to continue.

7050: NO PART CLAMPED

After switching on or after an the vice is neither at the open position nor at the closed position.

NC-Start is locked.

Traverse the vice manually on a valid end position.

7051: DIVIDING HEAD NOT LOCKED!

Either the dividing head is in an undefined position after the machine has been switched on, or the locking signal after a dividing process is missing.

Initiate the dividing process, check, respectively adjust the proximity switch for locking.

7054: VICE OPEN

Cause: the workpiece is not clamped

When switching on the main spindle with M3/M4 alarm 6072 (vice not ready) will be released.

Remedy: Clamp

7055: OPEN TOOL CLAMPING SYSTEM

A tool is clamped in the main spindle and the control does not recognize the corresponding T number.

Eject the tool from the main spindle when the door is open by means of the PC keys "Strg" and " 1 ".

7056: SETTING DATA INCORRECT

An invalid tool number is stored in the setting data.

Delete the setting data in the machine directory xxxxx.pls.

7057: TOOLHOLDER OCCUPIED

The clamped tool cannot be positioned in the tool turret since the position is occupied.

Eject the tool from the main spindle when the door is open by means of the PC keys "Strg" and " 1 ".

7058: RETRACTING THE AXES

The position of the tool turret arm cannot be clearly defined during the tool change.

Open the machine door, push the tool turret magazine backwards to the stop. Move the milling head in the JOG mode upwards to the Z reference switch and then traverse the reference point.

7270: OFFSET COMPENSATION ACTIVE !

Only with PC-MILL 105

Offset compensation activated by the following operation sequence.

- Reference point not active
- Machine in reference mode
- Key switch in manual operation
- Press STRG (or CTRL) and simultaneously 4

This must be carried out if prior to the tool change procedure spindle positioning is not completed (tolerance window too large)

7271: COMPENSATION FINISHED, DATA SAVED !

see 7270

cuu duong than cong . com

PC TURN 50 / 55 / 105 / 120 / 125 / 155
Concept TURN 55 / 105 / 155 / 250
Concept MILL 250
EMCOMAT E160
EMCOMILL C40

6000: EMERGENCY OFF

The EMERGENCY OFF key was pressed.
The reference position will be lost, the auxiliary drives will be switched off.
Remove the endangering situation and restart machine and software.

6001: PLC-CYCLE TIME EXCEEDING

The auxiliary drives will be switched off.
Contact EMCO Service.

6002: PLC - NO PROGRAM CHARGED

The auxiliary drives will be switched off.
Contact EMCO Service.

6003: PLC - NO DATA UNIT

The auxiliary drives will be switched off.
Contact EMCO Service.

6004: PLC - RAM MEMORY FAILURE

The auxiliary drives will be switched off.
Contact EMCO Service.

6005: K2 OR K3 NOT DE-ENERGIZED

Turn machine on/off. Defective security board.

6006 EMERGENCY-OFF RELAY K1 NOT DE-ENERGIZED

Turn machine on/off. Defective security board.

6007 SAFETY CIRCUIT FAULT

6008: MISSING CAN SUBSCRIBER

The PLC-CAN board is not identified by the control.
Check the interface cable and the power supply of the CAN board.

6009: SAFETY CIRCUIT FAULT

6010: DRIVE X-AXIS NOT READY

The step motor board is defective or too hot, a fuse is defective, over- or undervoltage from mains.

A running program will be stopped, the auxiliary drives will be switched off, the reference position will be lost.

Check fuses or contact EMCO service.

6011: DRIVE Z-AXIS NOT READY

see 6010.

6012: DRIVE Z-AXIS NOT READY

see 6010.

6013: MAIN DRIVE NOT READY

Main drive power supply defective or main drive too hot, fuse defective, over- or undervoltage from mains.

A running program will be stopped, the auxiliary drives will be switched off.

Check fuses or contact EMCO Service.

6014: NO MAIN SPINDLE SPEED

This alarm will be released, when the spindle speed is lower than 20 rpm because of overload.

Alter cutting data (feed, infeed, spindle speed).

The CNC program will be aborted, the auxiliary drives will be switched off.

6015: NO DRIVEN TOOL SPINDLE SPEED

see 6014.

6016: AUTOMATIC TOOL TURRET SIGNAL COUPLED MISSING

6017: AUTOMATIC TOOL TURRET SIGNAL UNCOUPLED MISSING

In the tool turret that can be coupled, the position of the coupling and uncoupling magnet is monitored by means of two proximity switches. It has to be made sure that the coupling is in the rear stop position so that the tool turret can get to the next tool position. Equally, during operation with driven tools the coupling has to be safe in the front stop position.

Check and adjust the cables, the magnet and the stop position proximity switches.

6018: AS SIGNALS, K4 OR K5 NOT DE-ENERGIZED

Turn machine on/off. Defective security board.

6019: POWER SUPPLY MODULE NOT READY

Turn machine on/off. Power supply module, defective axis controller 6020 AWZ drive failure turn machine on/off, defective axis controller.

6021: COLLET TIME OUT

During closing of the clamping device the pressure switch has not reacted within one second.

6022: CLAMPING DEVICE BOARD DEFECTIVE

The signal "clamping device clamped" is constantly released, even though no command has been given. Replace the board.

6023: COLLET PRESSURE MONITORING

The pressure switch turns off when the clamping device is closed (compressed air failure for more than 500ms).

6024: MACHINE DOOR OPEN

The door was opened while a machine movement. The program will be aborted.

6025: GEARBOX COVER NOT CLOSED

The gearbox cover was opened while a machine movement. A running CNC program will be aborted.

Close the cover to continue.

6026: MOTOR PROTECTION COOLANT PUMP RELEASED

6027: DOOR LIMIT SWITCH DEFECTIVE

The limit switch of the automatic door is displaced, defective, wrong cabled. Contact EMCO service.

6028: DOOR TIMEOUT

The automatic door sticks, the pressured air supply is insufficient, the limit switch is displaced. Check door, pressured air supply, limit switch or contact EMCO service.

6029: TAILSTOCK QUILL TIME EXCEED

The tailstock quill does not reach a final position within 10 seconds.

Adjust the control and the stop position proximity switches, or the tailstock quill is stuck.

6030: NO PART CLAMPED

No workpiece inserted, vice cheek displaced, control cam displaced, hardware defective. Adjust or contact EMCO service.

6031: QUILL FAILURE

6032: TOOL CHANGE TIMEOUT

see alarm 6041.

6033: TOOL TURRET SYNC ERROR

Hardware defective.

Contact EMCO service.

6037: CHUCK TIMEOUT

The pressure switch does not react within one second when the clamping device is closed.

6039: CHUCK PRESSURE FAILURE

The pressure switch turns off when the clamping device is closed (compressed air failure for more than 500ms).

6040: TOOL TURRET INDEX FAILURE

The tool turret is in no locked position, tool turret sensor board defective, cabling defective, fuse defective.

A running CNC program will be stopped.

Swivel the tool turret with the tool turret key, check fuses or contact EMCO service.

6041: TOOL CHANGE TIMEOUT

Tool drum sticks (collision?), fuse defective, hardware defective.

A running CNC program will be stopped.

Check for collisions, check fuses or contact EMCO service.

6042: TOOL TURRET OVERHEAT

Tool turret motor too hot.

With the tool turret a max. of 14 swivel procedures a minute may be carried out.

6043: TOOL CHANGE TIMEOUT

Tool drum sticks (collision?), fuse defective, hardware defective.

A running CNC program will be stopped.

Check for collisions, check fuses or contact EMCO service.

6045: TOOL TURRET SYNC MISSING

Hardware defective.

Contact EMCO service.

6046: TOOL TURRET ENCODER FAULT

Fuse defective, hardware defective.

Check fuses or contact EMCO service.

6048: CHUCK NOT READY

Attempt to start the spindle with open chuck or without clamped workpiece.

Chuck sticks mechanically, insufficient pressured air supply, fuse defective, hardware defective. Check fuses or contact EMCO service.

6049: COLLET NOT READY

see 6048

6050: M25 DURING SPINDLE ROTATION

With M25 the main spindle must stand still (consider run-out time, evtl. program a dwell)

6055: NO PART CLAMPED

This alarm occurs when with rotating spindle the clamping device or the tailstock reach the end position.

The workpiece has been pushed out of the chuck or has been pushed into the chuck by the tailstock.

Check clamping device settings, clamping forces, alter cutting data.

6056: QUILL NOT READY

Attempt to start the spindle or to move an axis or to swivel the tool turret with undefined tailstock position.

Tailstock is locked mechanically (collision), insufficient pressured air supply, fuse defective, magnetic switch defective.

Check for collisions, check fuses or contact EMCO service.

6057: M20/M21 DURING SPINDLE ROTATION

With M20/M21 the main spindle must stand still (consider run-out time, evtl. program a dwell)

6058: M25/M26 DURING QUILL FORWARD

To actuate the clamping device in an NC program with M25 or M26 the tailstock must be in back end position.

6059: C-AXIS SWING IN TIMEOUT

C-axis does not swivel in within 4 seconds.

Reason: not sufficient air pressure, and/or mechanics stuck.

6060: C-AXIS INDEX FAILURE

When swivelling in the C-axis the limit switch does not respond.

Check pneumatics, mechanics and limit switch.

6064: AUTOMATIC DOOR NOT READY

Door sticks mechanically (collision), insufficient pressured air supply, limit switch defective, fuse defective.

Check for collisions, check fuses or contact EMCO service.

6065: LOADER MAGAZINE FAILURE

Loader not ready.

Check if the loader is switched on, correctly connected and ready for operation and/or disable loader (WinConfig).

6066: CLAMPING DEVICE FAILURE

No compressed air at the clamping device

Check pneumatics and position of the clamping device proximity detectors.

6067: NO COMPRESSED AIR

Turn the compressed air on, check the setting of the pressure switch.

6068: MAINDRIVE OVERTEMPERATURE**6070: LIMIT SWITCH TAILSTOCK SLEEVE ACTIVE****6071: LIMIT SWITCH X AXIS ACTIVE****6072: LIMIT SWITCH Z AXIS ACTIVE****6073: CHUCK GUARD OPEN****6074: NO FEEDBACK FROM USB-PLC**

Turn machine on/off. Check cabling, defective USB board.

6075: AXIS LIMIT SWITCH TRIGGERED**6900 USBPLC not available**

Cause: USB communication with the safety board could not be established.

Remedy: Switch the machine off and on again. Please contact the EMCO after-sales service in case the error occurs repeatedly.

6901 Error emergency-off relay USBPLC

Cause: USBPLC EMERGENCY-OFF relay error.

Remedy: Switch the machine off and on again. Please contact the EMCO after-sales service in case the error occurs repeatedly.

6902 Error standstill monitoring X

Cause: Unauthorized movement of the X axis in the current operating condition.

Remedy: Delete the alarm with the RESET button and switch the machine off and on again. Please contact the EMCO after-sales service in case the error occurs repeatedly.

6903 Error standstill monitoring Z

Cause: Unauthorized movement of the Z axis in the current operating condition.

Remedy: Delete the alarm with the RESET button and switch the machine off and on again. Please contact the EMCO after-sales service in case the error occurs repeatedly.

6904 Error alive circuit PLC

Cause: Error in the connection (Watchdog) of the safety board with the PLC.

Remedy: Delete the alarm with the RESET button and switch the machine off and on again. Please contact the EMCO after-sales service in case the error occurs repeatedly.

6905 Error overspeed spindle

Cause: The main spindle speed exceeds the maximum permissible value for the current operating condition.

Remedy: Delete the alarm with the RESET button and switch the machine off and on again. Please contact the EMCO after-sales service in case the error occurs repeatedly.

6906 Error enable pulses I/F-module

Cause: ACC-PLC did not shutdown the input/negative feeder-module.

Remedy: Delete the alarm with the RESET button and switch the machine off and on again. Please contact the EMCO after-sales service in case the error occurs repeatedly.

6907 Error standstill monitoring main drive

Cause: Unexpected warm up of the main spindle in the operating condition.

Remedy: Delete the alarm with the RESET button and switch the machine off and on again. Please contact the EMCO after-sales service in case the error occurs repeatedly.

6908 Error main drive enable without spindle start

Cause: The release of the control unit of the main spindle was given by the ACC-PLC without the spindle-start key being pressed.

Remedy: Delete the alarm with the RESET button and switch the machine off and on again. Please contact the EMCO after-sales service in case the error occurs repeatedly.

6909 Error standstill monitoring Y

Cause: Unauthorized movement of the Y axis in the current operating condition.

Remedy: Delete the alarm with the RESET button and switch the machine off and on again. Please contact the EMCO after-sales service in case the error occurs repeatedly.

6910 Error standstill axes

Cause: Unauthorized movement of the axis in the current operating condition.

Remedy: Delete the alarm with the RESET button and switch the machine off and on again. Please contact the EMCO after-sales service in case the error occurs repeatedly.

6911 Error overspeed axis

Cause: The feed of the axes exceeds the maximum permissible value for the current operating condition.

Remedy: Delete the alarm with the RESET button and switch the machine off and on again. Please contact the EMCO after-sales service in case the error occurs repeatedly.

6912 Error overspeed X

Cause: The feed of the X axis exceeds the maximum permissible value for the current operating condition.

Remedy: Delete the alarm with the RESET button and switch the machine off and on again. Please contact the EMCO after-sales service in case the error occurs repeatedly.

6913 Error overspeed Y

Cause: The feed of the Y axis exceeds the maximum permissible value for the current operating condition.

Remedy: Delete the alarm with the RESET button and switch the machine off and on again. Please contact the EMCO after-sales service in case the error occurs repeatedly.

6914 Error overspeed Z

Cause: The feed of the Y axis exceeds the maximum permissible value for the current operating condition.

Remedy: Delete the alarm with the RESET button and switch the machine off and on again. Please contact the EMCO after-sales service in case the error occurs repeatedly.

7000: INVALID TOOL NUMBER PROGRAM-MED

The tool position was programmed larger than 8.

The CNC program will be stopped.

Interrupt program with RESET and correct the program.

7007: FEED HOLD

In the robotic mode a HIGH signal is at input E3.7. Feed Stop is active until a low signal is at E3.7.

7016: SWITCH ON AUXILIARY DRIVES

The auxiliary drives are off. Press the AUX ON key for at least 0.5 sec. (to avoid accidentally switching on) to switch on the auxiliary drives (also a lubricating pulse will be released).

7017: REFERENCE MACHINE

Approach the reference point.

When the reference point is not active, manual movements are possible only with key switch at position "setting operation".

7018: TURN KEY SWITCH

With NC-Start the key switch was in position "setting operation".

NC-Start is locked.

Turn the key switch in the position "automatic" to run a program.

7019: PNEUMATIC LUBRICATION MONITORING!

Refill pneumatic oil

7020: SPECIAL OPERATION MODE ACTIVE

Special operation mode: The machine door is opened, the auxiliary drives are switched on, the key switch is in position "setting operation" and the consent key is pressed.

Manual traversing the axes is possible with open door. Swivelling the tool turret is possible with open door. Running a CNC program is possible only with standing spindle (DRYRUN) and SINGLE block operation.

For safety: If the consent key is pressed for more than 40 sec. the function of this key is interrupted, the consent key must be released and pressed again.

7021: TOOL TURRET NOT LOCKED

The tool turret operating was interrupted.

NC start and spindle start are locked. Press the tool turret key in the RESET status of the control.

7022: COLLECTION DEVICE MONITORING

Time exceed of the swivelling movement.

Check the pneumatics, respectively whether the mechanical system is jammed (possibly a work-piece is jammed).

7023: ADJUST PRESSURE SWITCH !

During opening and closing of the clamping device the pressure switch has to turn off and on once.

Adjust the pressure switch. This alarm does not exist any more for versions starting with PLC 3.10.

7024: ADJUST CLAMPING DEVICE PROXIMITY SWITCH !

When the clamping device is open and the position stop control is active, the respective proximity switch has to feed back that the clamping device is "Open".

Check and adjust the clamping device proximity switch, check the cables.

7025 WAITING TIME MAIN DRIVE !

The LENZE frequency converter has to be separated from the mains supply for at least 20 seconds before you are allowed to switch it on again. This message will appear when the door is quickly opened/ closed (under 20 seconds).

7026 PROTECTION MAIN MOTOR FAN RELEASED!

7038: LUBRICATION SYSTEM FAULT

The pressure switch is defective or gagged.
NC-Start is locked. This alarm can be reset only by switching off and on the machine.
Contact EMCO service.

7039: LUBRICATION SYSTEM FAULT

Not enough lubricant, the pressure switch is defective.
NC-Start is locked.
Check the lubricant and lubricate manually or contact EMCO service.

7040: MACHINE DOOR OPEN

The main drive can not be switched on and NC-Start can not be activated (except special operation mode)
Close the machine to run a program.

7041: GEARBOX COVER OPEN

The main spindle cannot be switched on and NC start cannot be activated.
Close the gearbox cover in order to start a CNC program.

7042: INITIALIZE MACHINE DOOR

Every movement and NC-Start are locked.
Open and close the machine door to initialize the safety circuits.

7043: PIECE COUNT REACHED

A predetermined number of program runs was reached. NC-Start is locked. Reset the counter to continue.

7048: CHUCK OPEN

This message shows that the chuck is open. It will disappear if a workpiece will be clamped.

7049: CHUCK - NO PART CLAMPED

No part is clamped, the spindle can not be switched on.

7050: COLLET OPEN

This message shows that the collet is open. It will disappear if a workpiece will be clamped.

7051: COLLET - NO PART CLAMPED

No part is clamped, the spindle can not be switched on.

7052: QUILL IN UNDEFINED POSITION

The tailstock is in no defined position.
All axis movements, the spindle and the tool turret are locked.
Drive the tailstock in back end position or clamp a workpiece with the tailstock.

7053: QUILL - NO PART CLAMPED

The tailstock reached the front end position. Traverse the tailstock back to the back end position to continue.

7054: NO PART CLAMPED

No part clamped, switch-on of the spindle is locked.

7055: CLAMPING DEVICE OPEN

This message indicates that the clamping device is not in clamping state. It disappears as soon as a part is clamped.

7060 RETRACT SLEEVE LIMIT SWITCH !

7061 RETRACT X AXIS LIMIT SWITCH !

7062 RETRACT Z AXIS LIMIT SWITCH !

7063 OIL LEVEL CENTRAL LUBRICATION !

7064 CHUCK GUARD OPEN !

7065 MOTOR PROTECTION COOLANT PUMP RELEASED !

7066 CONFIRM TOOL !

7067 MANUAL OPERATING MODE

7068 X AXIS HANDWHEEL ACTIVE

7069 Y AXIS HANDWHEEL ACTIVE

7070 Z AXIS HANDWHEEL ACTIVE

7071 VERTICAL TOOL CHANGE

7072 HORIZONTAL TOOL CHANGE

7073 RETRACT Y AXIS LIMIT SWITCH !

7074 CHANGE TOOL

cuu duong than cong . com

Axis Controller Alarms

8000 Fatal Error AC

8100 Fatal init error AC

Cause: Internal error

Remedy: Restart software or reinstall when necessary, report to EMCO, if repeatable.

8101 Fatal init error AC

see 8101.

8102 Fatal init error AC

see 8101.

8103 Fatal init error AC

see 8101.

8104 Fatal system error AC

see 8101.

8105 Fatal init error AC

see 8101.

8106 No PC-COM card found

Cause: PC-COM board can not be accessed (ev. not mounted).

Remedy: Mount board, adjust other address with jumper

8107 PC-COM card not working

see 8106.

8108 Fatal error on PC-COM card

see 8106.

8109 Fatal error on PC-COM card

see 8106.

8110 PC-COM init message missing

Cause: Internal error

Remedy: Restart software or reinstall when necessary, report to EMCO, if repeatable.

8111 Wrong configuration of PC-COM

see 8110.

8113 Invalid data (pccom.hex)

see 8110.

8114 Programming error on PC-COM

see 8110.

8115 PC-COM packet acknowledge missing

see 8110.

8116 PC-COM startup error

see 8110.

8117 Fatal init data error (pccom.hex)

see 8110.

8118 Fatal init error AC

see 8110, ev. insufficient RAM memory

8119 PC interrupt no. not valid

Cause: The PC interrupt number can not be used.

Remedy: Find out free interrupt number in the Windows95 system control (allowed: 5,7,10, 11, 12, 3, 4 und 5) and enter this number in WinConfig.

8120 PC interrupt no. unmaskable

see 8119

8121 Invalid command to PC-COM

Cause: Internal error or defective cable

Remedy: Check cables (screw it); Restart software or reinstall when necessary, report to EMCO, if repeatable.

8122 Internal AC mailbox overrun

Cause: Internal error

Remedy: Restart software or reinstall when necessary, report to EMCO, if repeatable.

8123 Open error on record file

Cause: Internal error

Remedy: Restart software or reinstall when necessary, report to EMCO, if repeatable.

8124 Write error on record file

Cause: Internal error

Remedy: Restart software or reinstall when necessary, report to EMCO, if repeatable.

8125 Invalid memory for record buffer

Cause: Insufficient RAM, record time exceeding.

Remedy: Restart software, ev. remove drivers etc. to gain more RAM, reduce record time.

8126 AC Interpolation overrun

Cause: Ev. insufficient computer performance.

Remedy: Set a longer interrupt time in WinConfig. This may result in poorer path accuracy.

8127 Insufficient memory

Cause: Insufficient RAM

Remedy: Close other programs, restart software, ev. remove drivers etc. to gain more RAM.

8128 Invalid message to AC

Cause: Internal error

Remedy: Restart software or reinstall when necessary, report to EMCO, if repeatable.

8129 Invalid MSD data - axisconfig.

see 8128.

8130 Internal init error AC

see 8128.

8130 Internal init error AC

see 8128.

8132 Axis accessed by multiple channels

see 8128.

8133 Insufficient NC block memory AC

see 8128.

8134 Too much center points programmed

see 8128.

8135 No centerpoint programmed

see 8128.

8136 Circle radius too small

see 8128.

8137 Invalid for Helix specified

Cause: Wrong axis for helix. The combination of linear and circular axes does not match.

Remedy: Program correction.

8140 Maschine (ACIF) not responding

Cause: Machine off or not connected.

Remedy: Switch on machine or connect.

8141 Internal PC-COM error

Cause: Internal error

Remedy: Restart software or reinstall when necessary, report to EMCO, if repeatable.

8142 ACIF Program error

Cause: Internal error

Remedy: Restart software or reinstall when necessary, report to EMCO, if repeatable.

8143 ACIF packet acknowledge missing

see 8142.

8144 ACIF startup error

see 8142.

8145 Fatal init data error (acif.hex)

see 8142.

8146 Multiple request for axis

see 8142.

8147 Invalid PC-COM state (DPRAM)

see 8142.

8148 Invalid PC-COM command (CNo)

see 8142.

8149 Invalid PC-COM command (Len)

see 8142.

8150 Fatal ACIF error

see 8142.

8151 AC Init Error (missing RPG file)

see 8142.

8152 AC Init Error (RPG file format)

see 8142.

8153 FPGA program timeout on ACIF

see 8142.

8154 Invalid Command to PC-COM

see 8142.

8155 Invalid FPGA packet acknowledge

see 8142 or hardware error on ACIF board (contact EMCO Service).

8156 Sync within 1.5 revol. not found

see 8142 or Bero hardware error (contact EMCO Service).

8157 Data record done

see 8142.

8158 Bero width too large (referencing)

see 8142 or Bero hardware error (contact EMCO Service).

8159 Function not implemented

Bedeutung: In normal operation this function can not be executed

8160 Axis synchronization lost axis 3..7

Cause: Axis spins or slide is locked, axis synchronisation was lost

Remedy: Approach reference point

8161 X-Axis synchronization lost

Step loss of the step motor. Causes:

- Axis mechanically blocked
- Axis belt defective
- Distance of proximity detector too large (>0,3mm)
 - or proximity detector defective
- Step motor defective

8162 Y-Axis synchronization lost

see 8161

8163 Z-Axis synchronization lost

see 8161

8164 Software limit switch max axis 3..7

Cause: Axis is at traverse area end

Remedy: Retract axis

8168 Software limit overtravel axis 3..7

Cause: Axis is at traverse area end

Remedy: Retract axis

8172 Communication error to machine

Cause: Internal error

Remedy: Restart software or reinstall when necessary, report to EMCO, if repeatable.

Check connection PC-machine, eventually eliminate distortion sources.

8173 INC while NC program is running

Remedy: Stop the program with NC stop or with Reset. Traverse the axis.

8174 INC not allowed

Cause: At the moment the axis is in motion.

Remedy: Wait until the axis stops and then traverse the axis.

8175 MSD file could not be opened

Cause: Internal error

Remedy: Restart software oder bei Bedarf neu installieren, report to EMCO, if repeatable.

8176 PLS file could not be opened

see 8175.

8177 PLS file could not be accessed

see 8175.

8178 PLS file could not be written

see 8175.

8179 ACS file could not be opened

see 8175.

8180 ACS file could not be accessed

see 8175.

8181 ACS file could not be written

see 8175.

8183 Gear too high

Cause: The selected gear step is not allowed at the machine.

8184 Invalid interpolaton command**8185 Forbidden MSD data change**

see 8175.

8186 MSD file could not be opened

see 8175.

8187 PLC program error

see 8175.

8188 Gear command invalid

see 8175.

8189 Invalid channel assignement

see 8175.

8190 Invalid channel within message

see 8175.

8191 Invalid jog feed unit

Cause: The machine does not support the rotation feed in the JOG operating mode.

Remedy: Order a software update from EMCO.

8192 Invalid axis in command

see 8175.

8193 Fatal PLC error

see 8175.

8194 Thread without length

Cause: The programmed target coordinates are identical to the starting coordinates.

Remedy: Correct the target coordinates.

8195 No thread slope in leading axis

Remedy: Program thread pitch

8196 Too many axis for thread

Remedy: Program max. 2 axes for thread.

8197 Thread not long enough

Cause: Thread length too short.

With transition from one thread to the other the length of the second thread must be sufficient to produce a correct thread.

Remedy: Longer second thread or replace it by a linear interpolation (G1).

8198 Internal error (to many threads)

see 8175.

8199 Internal error (thread state)

Cause: Internal error

Remedy: Restart software or reinstall when necessary, report to EMCO, if repeatable.

8200 Thread without spindle on

Remedy: Switch on spindle

8201 Internal thread error (IPO)

see 8199.

8201 Internal thread error (IPO)

see 8199.

8203 Fatal AC error (0-ptr IPO)

see 8199.

8204 Fatal init error: PLC/IPO running

see 8199.

8205 PLC Runtime exceeded

Cause: Insufficient computer performance

8206 Invalid PLC M-group initialisation

see 8199.

8207 Invalid PLC machine data

see 8199.

8208 Invalid application message

see 8199.

8212 Rotation axis not allowed

see 8199.

8213 Circle and rotation axis can't be interpolated**8214 Thread and rotation axis cant't be interpolated****8215 Invalid state**

see 8199.

8216 No rotation axis for rotation axis switch

see 8199.

8217 Axis type not valid!

Cause: Switching during the rotary axis operating mode when the spindle is running.

Remedy: Stop the spindle and switch over to the rotary axis operating mode.

8218 Referencing round axis without selected round axis!

see 8199.

8219 Thread not allowed without spindle encoder!

Cause: Thread cutting, respectively tapping is only possible with spindles with encoders.

8220 Buffer length exceeded in PC send message!

see 8199.

8221 Spindle release although axis is no spindle!

see 8199.

8222 New master spindle is not valid

Cause: The indicated master spindle is not valid when switching over to the master spindle.

Remedy: Correct the spindle number.

8224 Invalid stop mode

see 8199.

8225 Invalid parameter for BC_MOVE_TO_IO!

Cause: The machine is not configured for touch probes. A traversing movement with rotary axis is not allowed during touch probe operating mode.

Remedy: Remove the rotary axis movement from the traversing movement.

8226 Rotary axis switch not valid (MSD data)!

Cause: The indicated spindle does not have a rotary axis.

8228 Rotary axis switch not allowed while axis move!

Cause: The rotary axis has moved during switching over to the spindle operating mode.

Remedy: Stop the rotary axis before switching.

8229 Spindle on not allowed while rotary axis is active!**8230 Program start not allowed due to active spindle rotation axis!****8231 Axis configuration (MSD) for TRANSMIT not valid!**

Cause: Transmit is not possible at this machine.

8232 Axis configuration (MSD) for TRACYL not valid!

Cause: Tracyl is not possible at this machine.

8233 Axis not available while TRANSMIT/TRACYL is active!

Cause: Programming of the rotary axis is not allowed during Transmit/ Tracyl.

8234 Axis control grant removed by PLC while axis interpolates!

Cause: Internal error

Remedy: Delete error with reset and inform EMCO.

8235 Interpolation invalid while axis control grant is off by PLC!

see 8234.

8236 TRANSMIT/TRACYL activated while axis or spindle moves!

see 8234.

8237 Motion through pole in TRANSMIT!

Cause: It is not allowed to move through the coordinates X0 Y0 in Transmit.

Remedy: Alter the traversing movement.

8238 Speed limit in TRANSMIT exceeded!

Cause: The traversing movement gets too close to the coordinates X0 Y0. In order to observe the programmed feed rate, the maximum speed of the rotary axis would have to be exceeded.

Remedy: Reduce the feed rate. Set the value of the C-axis feed limitation in WinConfig, machine data settings / general machine data/ to 0.2. Thus, the feed rate will be automatically reduced near the coordinates X0 Y0.

8239 DAU exceeded 10V limit!

Cause: Internal error

Remedy: Start the software again or install it anew. Report the error to EMCO.

8240 Function not valid during active transformation (TRANSMIT/TRACYL)!

Cause: The Jog and INC operating mode are not possible during Transmit in X/C and during Tracyl in the rotary axis.

8241 TRANSMIT not enabled (MSD)!

Cause: Transmit is not possible at this machine.

8242 TRACYL not enabled (MSD)!

Cause: Tracyl is not possible at this machine.

8243 Round axis invalid during active transformation!

Cause: It is not allowed to program the rotary axis during Transmit/Tracyl.

8245 TRACYL radius = 0!

Cause: When selecting Tracyl, a radius of 0 was used.

Remedy: Correct the radius.

8246 Offset alignment not valid for this state!

see 8239.

8247 Offset alignment: MSD file write protected!**8248 Cyclic supervision failed!**

Cause: The communication with the machine keyboard is interrupted.

Remedy: Start the software again or install it anew. Report the error to EMCO.

8249 Axis motion check alarm!

see 8239

8250 Spindle must be rotation axis !

see 8239

8251 Lead for G331/G332 missing !

Cause: The threading pitch is missing or the starting coordinates are identical to the target coordinates.

Remedy: Program the threading pitch. Correct the target coordinates.

8252 Multiple or no linear axis programmed for G331/G332 !

Remedy: Program exactly one linear axis.

8253 Speed value for G331/G332 and G96 missing !

Cause: No cutting speed has been programmed.

Remedy: Program the cutting speed.

8254 Value for thread starting point offset not valid!

Cause: The thread starting point offset is not within the range of 0 to 360°.

Remedy: Correct the thread starting point offset.

8255 Reference point not in valid software limits!

Cause: The reference point has been defined outside the software limit switches.

Remedy: Correct the reference points in WinConfig.

8256 Spindle speed too low while executing G331/G332!

Cause: During tapping the spindle speed has decreased. Perhaps the incorrect threading pitch was used or the core drilling is not correct.

Remedy: Correct the threading pitch. Adapt the diameter to the core drilling.

8257 Real Time Module not active or PCI card not found!

Cause: ACC could not be started correctly or the PCI card in the ACC was not recognized.

Remedy: Report the error to EMCO.

8258 Error allocating Linux data!

see 8239.

8259 Current thread in sequence not valid!

Cause: One block of a thread in sequence has been programmed without thread G33.

Remedy: Correct the program.

8261 Missing thread in sequence !

Cause: A successive thread has not been programmed for a thread in sequence, the number has to be in accordance with the SETTHREADCOUNT () that has been defined before.

Remedy: Correct the number of threads in the thread in sequence and add a thread.

8262 Reference marks are not close enough !

Cause: The settings of the linear scale have been changed or the linear scale is defective.

Remedy: Correct the settings. Contact EMCO.

8263 Reference marks are too close together!

see 8262.

8265 No or wrong axis in axis switch command!

Cause: Internal error.

Remedy: Please contact the EMCO after-sales service.

22000 Gear change not allowed

Cause: Gear step change when the spindle is active.

Remedy: Stop the spindle and carry out a gear step change.

22270 Feed too high (thread)

Cause: Thread pitch too large / missing, Feed for thread reaches 80% of rapid feed

Remedy: Program correction, lower pitch or lower spindle speed for thread

Axis Controller Messages

8700 Execute REPOS in all axes before program start

Cause: After the program was stopped, the axes were manipulated with the hand wheel or with the jog keys and then a restart of the program was attempted.

Remedy: Before starting the program again, one should reposition the axes along the contour by executing "REPOS".

8701 No NCStop during offset align

Cause: The machine is currently executing an automatic offset adjustment. NC stop is not possible at this time.

Remedy: Wait until the offset adjustment is finished and then stop the program with NC stop.

8702 No NCStop during positioning after block search

Cause: The machine is currently finishing the block search operation and then it starts to go back to the last programmed position. No NC stop is possible in the meantime.

Remedy: Wait until positioning is finished and then stop the program with NC stop.

8703 Data record done

The recording of data is finished and the file record.acp has been copied to the installation folder.

Control alarms 2000 - 5999

The alarms are released by the software.

Fagor 8055 TC/MC
Heidenhain TNC 426
CAMConcept
EASY CYCLE

2000 departure missing

Cause: No movement after the tool radius compensation was deactivated in the current plane.

Remedy: Insert the departing movement in the current plane after having deactivated the tool radius compensation.

2001 TPC off missing

Cause: The tool radius compensation has not been deactivated.

Remedy: Deactivate the tool radius compensation.

2002 less than three moves for TPC

Cause: The tool radius compensation requires at least 3 movements in the current plane in order to calculate the tool radius compensation (movement for approach, compensated movement, departing movement).

2200 Syntax error in line %s, column %s

Cause: Syntax error in the program code.

2300 tracyl without corresponding round-axis invalid

Cause: Maybe the machine has no rotary axis.

3000 Traverse feed axis manually to position %s

Remedy: Move the axis manually to the required position.

4001 slot width too small

Cause: The tool radius is too large for the slot to be milled.

4002 slot length too small

Cause: The slot length is too small for the slot to be milled.

4003 length equal zero

Cause: Pocket length, pocket width, stud length, stud width are zero.

4004 slot width too big

Cause: The programmed slot width is larger than the slot length.

4005 depth equal zero

Cause: No machining takes place since no effective cutting depth has been defined.

4006 corner radius too big

Cause: The corner radius is too large for the size of the pocket.

4007 diameter too big

Cause: The remaining material (nominal diameter - diameter of the prebore) / 2 is larger than the tool diameter.

4008 diameter too small

Cause: The tool diameter is too large for the intended bore.

Remedy: Enlarge the nominal diameter and use a smaller milling cutter.

4009 length too small

Cause: Width and length must be larger than the double tool radius.

4010 diameter less equal zero

Cause: The pocket diameter, the stud diameter, etc. must not be zero.

4011 blank diameter too big

Cause: The diameter of the machined pocket must be larger than the diameter of the premachined pocket.

4012 blank diameter too small

Cause: The diameter of the machined stud must be smaller than the diameter of the premachined stud.

4013 start angle equal to end angle

Cause: Start angle and end angle for hole pattern are identical.

4014 tool radius 0 not permitted

Cause: Tool radius zero is not permitted.
Remedy: Select a valid tool.

4015 no outer contour defined

Cause: The contour file indicated in the cycle was not found.

4017 tool radius too big

Cause: For the programmed machining, a tool being too large was selected. Therefore, machining is not possible.

4018 allowance must not be 0

Cause: There were programmed finishing operations without finishing offset.

4019 too many iterations

Cause: The contour definitions are too complex for the roughing-out cycle.

Remedy: Simplify the contour.

4020 illegal radian correction

Cause: An error has occurred during the programming of the radius compensation.

Remedy: Check the cycle parameters.

4021 can't calculate parallel contour

Cause: The control was not able to calculate the tool radius compensation.

Remedy: Check the programmed contour for plausibility. Maybe contact EMCO.

4022 illegal contour definition

Cause: The programmed contour is not suited to the selected machining.

Remedy: Check the programmed contour.

4024 no contour definition

Cause: The contour file being defined in the cycle has not been found.

4025 internal calculation error

Cause: An unexpected error has occurred during calculation of the cycle movements.

Remedy: Please inform the EMCO after-sales service.

4026 allowance too big

Cause: A part of the finishing offset (for several finishing passes) is larger than the total finishing offset.

Remedy: Correct the finishing offsets.

4028 pitch 0 not permitted

Cause: The thread was programmed with pitch zero.

4029 undefined working mode

Cause: Internal error (invalid machining type for the thread).

4030 function not yet supported

Cause: Roughing out with pockets is not implemented yet.

Remedy: Please inform the EMCO after-sales service.

4031 value not permitted

Cause: An invalid retracting direction was programmed during inside turning.

4032 plunging must be defined

Cause: For the programmed cycle no cutting depth has been programmed.

4033 radius/chamfer too big

Cause: The radius, respectively the chamfer, cannot be inserted in the programmed contour.

Remedy: Reduce the radius, respectively the chamfer.

4034 diameter too big

Cause: The programmed starting point and the machining diameter are contradictory.

4035 diameter too small

Cause: The programmed starting point and the machining diameter are contradictory.

4036 unknown working direction

Cause: Internal error.

Remedy: Please inform the EMCO after-sales service.

4037 unknown working type

Cause: Internal error.

Remedy: Please inform the EMCO after-sales service.

4038 unknown sub cycle

Cause: Internal error.

Remedy: Please inform the EMCO after-sales service.

4039 rounding not possible

Cause: The programmed radius contradicts the rest of the cycle parameters.

4042 illegal tool width

Cause: The tool width for the cutting-off cycle must be defined.

4043 groove width too small

Cause: Internal error.

Remedy: Please inform the EMCO after-sales service.

4044 distance not defined

Cause: The distance for the multiple grooving cycle must not be zero.

4045 illegal allowance type

Cause: Internal error.

Remedy: Please inform the EMCO after-sales service.

4046 invalid speed

Cause: The spindle speed must be nonzero.

4047 invalid end point

Cause: The programmed end point contradicts the rest of the cycle definition.

4048 tool cut width too small

Cause: The cutting edge is too small for the programmed cutting depth.

4050 invalid distance

Cause: The hole patterns do not tally with the selected distance.

4052 working pattern not possible

Cause: Error in the definition of the hole pattern. The number of bores is contradictory.

4053 invalid start point

Cause: Internal error.

Remedy: Please inform the EMCO after-sales service.

4055 illegal working direction

Cause: The machining direction is contradictory to the rest of the cycle definition.

4057 plunging angle less equal zero

Cause: The plunging angle must be between 0 and 90 degree.

4058 chamfer too large

Cause: The programmed chamfer is too large for the pocket cycle.

4062 radius/chamfer too small

Cause: The radius, respectively the chamfer, cannot be machined with the current tool radius.

4066 invalid mill step

Cause: The mill step must be greater than zero.

4069 invalid angle

Cause: An angle of zero degree is not permitted.

4072 plunging too small

Cause: For the cycle, a cutting depth has been selected that leads to extra-long machining time.

4073 invalid clearance angle

Cause: The clearance angle indicated for the tool cannot be machined.

Remedy: Correct the clearance angle for the tool.

4074 contour-file not found

Cause: The contour file indicated in the cycle has not been found.

Remedy: Please select the contour file for the cycle.

4075 not machinable with selected tool

Cause: The tool is too wide for the programmed groove.

4200 leaving movement is missing

Cause: No movement after the tool radius compensation was deactivated in the current plane.

Remedy: Insert the departing movement in the current plane after having deactivated the tool radius compensation.

4201 G40 is missing

Cause: The tool radius compensation has not been deactivated.

Remedy: Deactivate the tool radius compensation.

4202 TPC requires at least three movements

Cause: The tool radius compensation requires at least 3 movements in the current plane in order to calculate the tool radius compensation.

4203 approaching movement not possible

Cause: It was not possible to calculate the approaching movement.

4205 leaving movement not possible

Cause: It was not possible to calculate the departing movement.

4209 TPC curve could not be calculated

Cause: It was not possible to calculate the tool radius compensation for the programmed contour.

4210 switching the plane is not allowed when TPC is switched on

Cause: The programmed plane must not be changed during the tool radius compensation.

Remedy: Remove the change of planes during the tool radius compensation.

5000 drill manually now**5001 contour has been adjusted to the programmed clearance angle**

Cause: The programmed contour was adapted to the programmed clearance angle. Maybe there will remain rest material that cannot be machined with this tool.

X: EmConfig

General

EmConfig is a configuration software for WinNC. EmConfig helps you to alter the settings of WinNC.

The most important settings are:

- Control language
- System of measurement mm - inch
- Activate accessories
- Selection of interface for control keyboard

Using EmConfig you can also activate diagnostic functions in case of troubles - that way you get help immediately.



Safety-related parameters are protected by a password. They can only be activated by set-up technicians or by technical support representatives.



Icon for EmConfig

How to start EmConfig

Open EmConfig.

In case there are several control types installed, a selection box will appear on the screen.

Select the required control type and click OK.

The following settings are only valid for the selected control type.

The window for EmConfig appears on the screen.

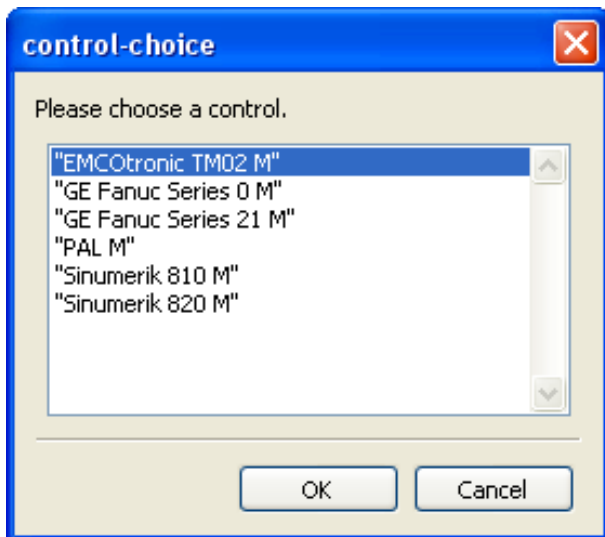

Selection box for control type

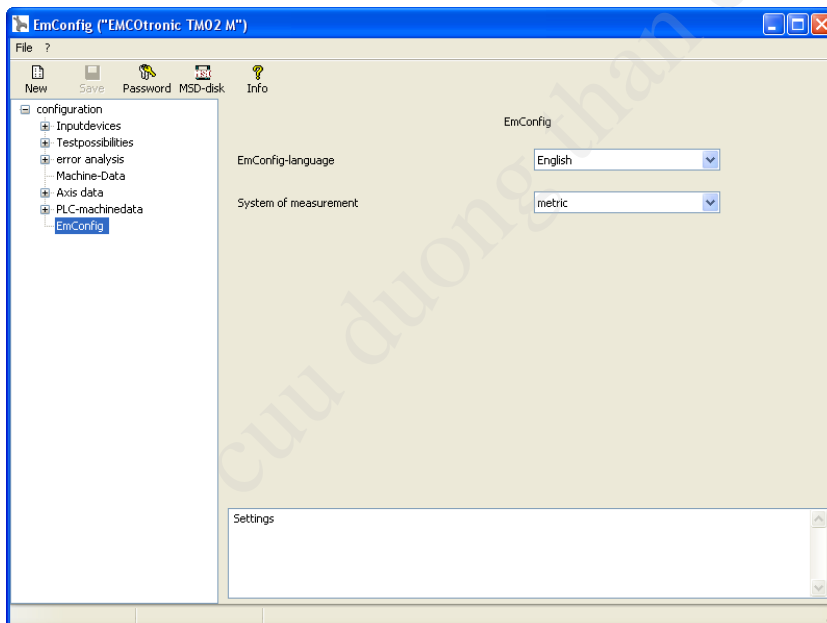

Change the language of EmConfig

Here you can change the language of EMConfig. In order to activate the settings, restart the program.

Note:

Select the desired menu item. The appropriate function is explained in the text box.

How to activate accessories

When you install accessories on your machine, you need to activate them here.

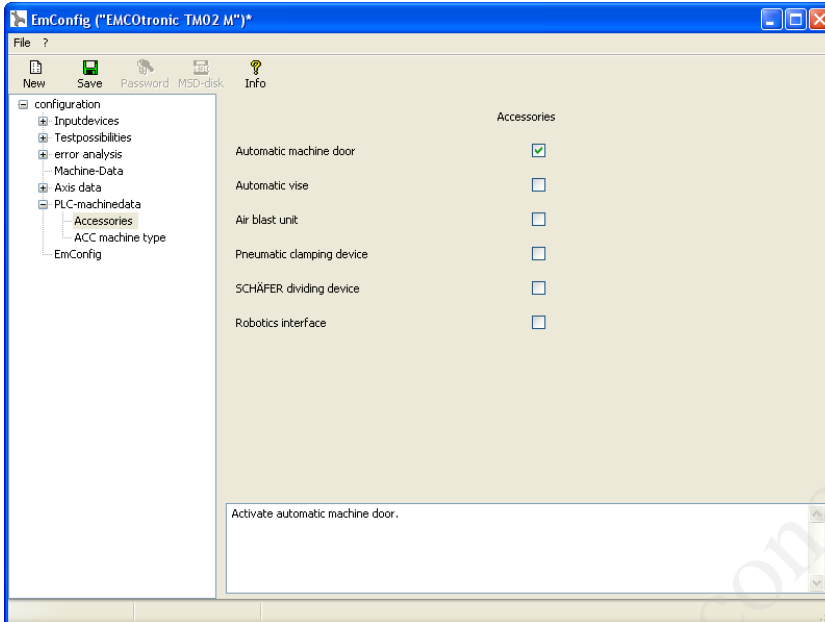

Activate accessories

How to save changes

After the settings, the changes must be saved.

Select "Save" or click on the icon.



Note:

Input fields highlighted in red indicate inadmissible values. Inadmissible values are not saved in EmConfig.



After saving the changes, create a machine data floppy disk (MSD) or a machine data USB flash drive.

How to create machine data floppy disk or machine data USB flash drive

After having changed the machine data, the machine data floppy disk or the machine data USB flash drive must be in the appropriate drive. Otherwise your changes cannot be saved and get lost.

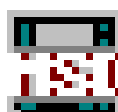

cuu duong than cong . com

Z: Software Installation

System requirements

The following minimum requirements must be met to run WinNC:

- Windows 98/2000 Servicepack 4 Update Rollup1/XP/Vista:
- PC Celeron or Pentium III
733MHz IBM-compatible
128 MB RAM, 256 MB RAM recommended
- VGA color graphic card (8MB or higher)
- 2 available USB connections
- network interface card (TCP/IP capable; only for ACC machines)
- 30 MB of free hard disk memory for each control type installed; CAMConcept 150 MB;
- latest service pack for operating system
- only required for HEIDENHAIN TNC 426 and FAGOR 8055:
Netscape Navigator or Commuincator 4.5 to 4.78 (6.x is not supported), or Internet Explorer 4.0, or RealPlayer 8 or later

Note:

AC95: Machine installations are only possible under Windows 98/ME.

Software installation

- Start Windows 98/ME/2000/XP/Vista
- AC95: Machine installations are only possible under 98/ME.
- Only under Windows 98: download USB driver from the internet and install it
- Connect USB flash drive
- Start EMCO menu
- The installation program starts
- The installation is guided by menus. Follow the instructions step by step.

Variants of WinNC

You can install EMCO WinNC for the following CNC control types:

- SINUMERIK 810/820 T and M
- SINUMERIK 810D/840D T and M
- EMCOTRONIC TM02 T and M
- PAL T and M
- HEIDENHAIN TNC 426
- FANUC Series 0-TC and 0-MC
- FANUC Series 21 TB and MB
- FAGOR 8055 TC and MC
- CAMConcept T and M
- EMCO EASY CYCLE T and M

In case there are several control types installed, a menu appears when starting EM Launch from which you can select the desired type.

The following versions can be installed from the WinNC variants:

- Demo license:
The demo license is valid for 30 days after the first use. 5 days before the demo license expires, you can enter another valid license key (see license manager)
- Programming station:
Programming and operation of the appropriate CNC control type is simulated by WinNC on your PC.
 - Single user license:
Authorizes to external programming of CNC-controlled machine tools on one PC workstation (machine-independent).
 - Multi-user license:
Authorizes to external programming of CNC-controlled machine tools. The multi-user license can be installed on an unlimited number of PC workstations or in a network within the institute registered by the licensor (machine-independent).
- Machine license:
This license allows to directly operate a PC-controlled machine (PC TURN, Concept TURN, PC MILL, Concept MILL) of WinNC as if it was operated by an ordinary CNC control.

Settings of the Interface Board

RS 485 - Board (AC88)

(PC TURN 50, PC MILL 50,
PC TURN 120, PCMILL 100)

With installation of the software a certain memory area (**memory area CC000 - D0000**) is assigned to the interface card.

If this area is already occupied, e.g. by another card or an Expanded Memory Manager, an alarm appears.

After this alarm act as following:

Alter jumper positions

By altering the jumpers the interface card can be switched to another memory area.

The following memory areas are available:

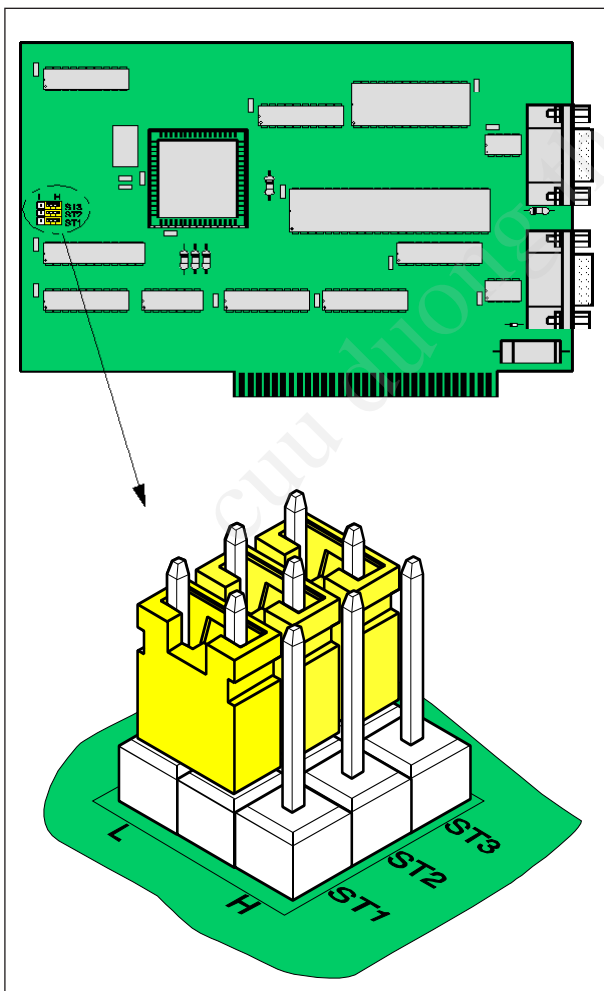

Jumper position on the interface board

RS 485						
Nr.	Jumper			Hexadecimal Memory Area		
	ST1	ST2	ST3		to	
1*	L	L	L	CC000	to	CC7FF
2	H	L	L	CC800	to	CCFFF
3	L	H	L	CD000	to	CD7FF
4	H	H	L	CD800	to	CDFFF
5	L	L	H	CE000	to	CE7FF
6	H	L	H	CE800	to	CEFFF
7	L	H	H	CF000	to	CF7FF
8	H	H	H	CF800	to	CFFFF

*) Basic position

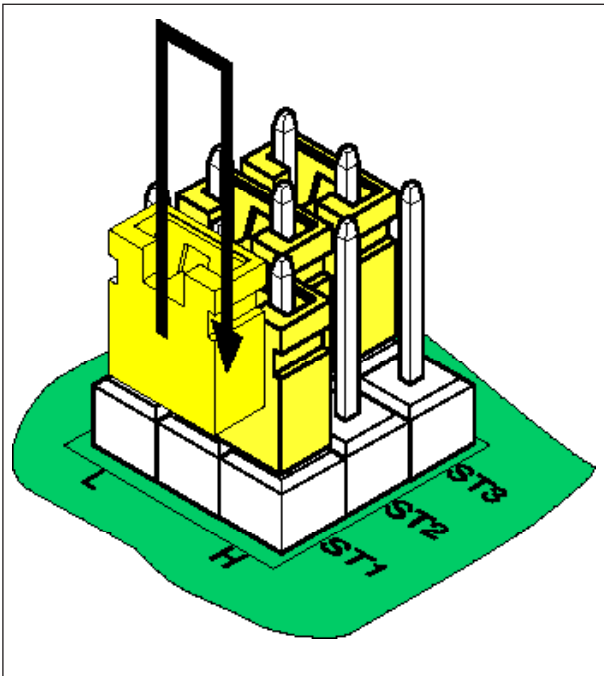

Alter jumper positions

Sequence:



Danger:

Mount and dismount the interface card only while the PC is disconnected to the net. Pull power cable!

- Remove the interface board from the PC.
- Place the jumpers ST1 - ST3 in the required position (positions 1 - 8 see table on previous page).
- Mount the interface board in the PC.
- Connet the PC to line and switch on.
- Retry installation of the software. When the alarm occurs again, try the next jumper position for installation.

PCCOM (RS 422) - Board (AC95)

(PC TURN 55, PC MILL 55
 PC TURN 105, PC MILL 105
 PC TURN 125, PC MILL 125
 PC TURN 155, PC MILL 155)

With installation of the software a certain memory area (**memory area CC000 - CFFFF**) is assigned to the interface card.

If this area is already occupied, e.g. by another card or an Expanded Memory Manager, an alarm appears.

After this alarm act as following:

Alter jumper positions

By altering the jumpers the interface card can be switched to another memory area.

The following memory areas are available:

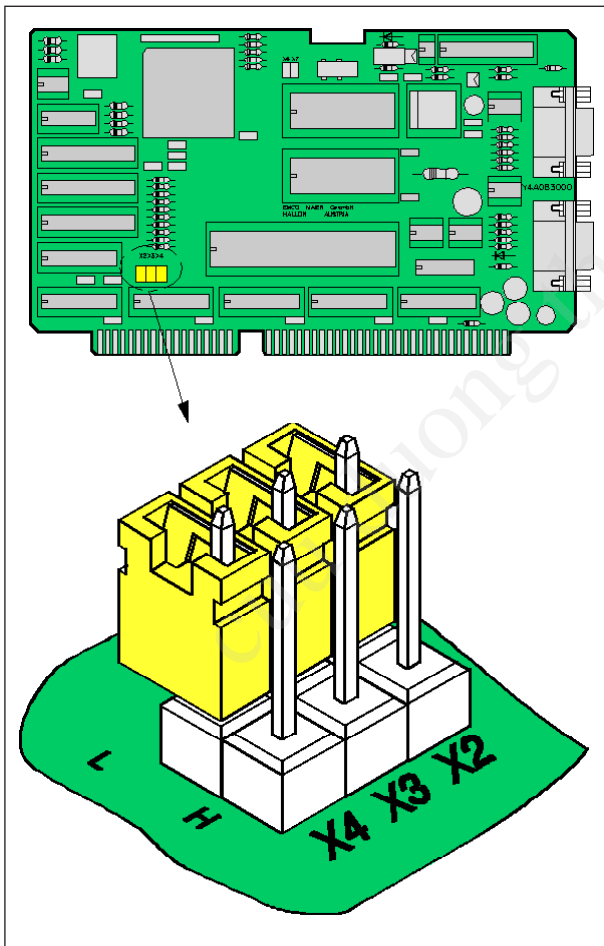

Jumper position on the interface board

RS 422						
Nr.	Jumper			Hexadecimal Memory Area		
	X2	X3	X4		to	
1*	L	L	L	CC000	to	CC7FF
2 ¹⁾	L	L	H	D8000	to	D87FF
3	L	H	L	CF800	to	CFFFF
4 ¹⁾	L	H	H	E0000	to	E07FF
5	H	L	L	CE000	to	CE7FF
6 ¹⁾	H	L	H	DF800	to	DFFFF
7 ¹⁾	H	H	L	D0000	to	D07FF
8 ¹⁾	H	H	H	E8000	to	E87FF

*) Basic position

1) From PCCOM- Board- version 1

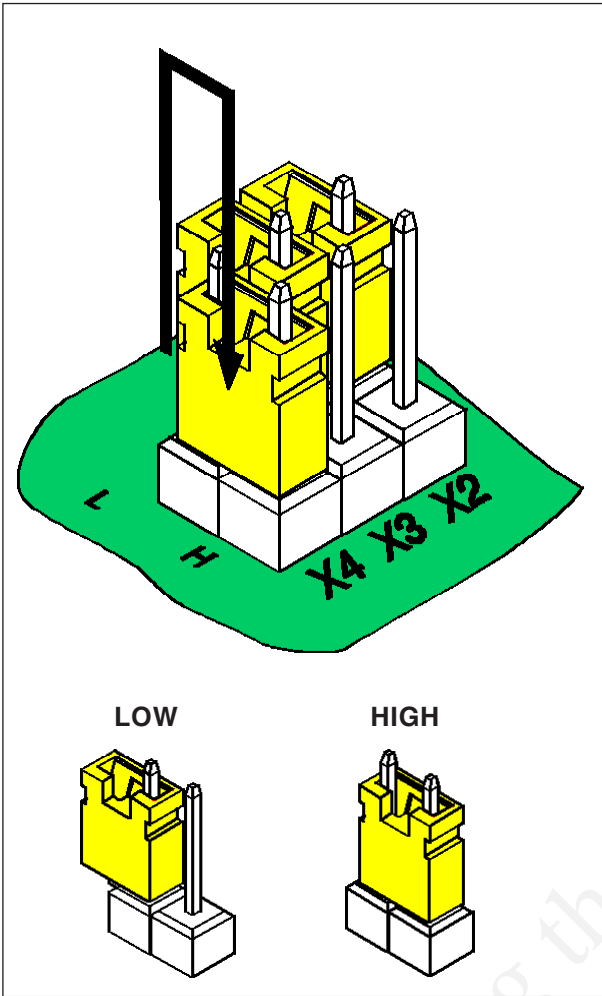

Alter jumper positions

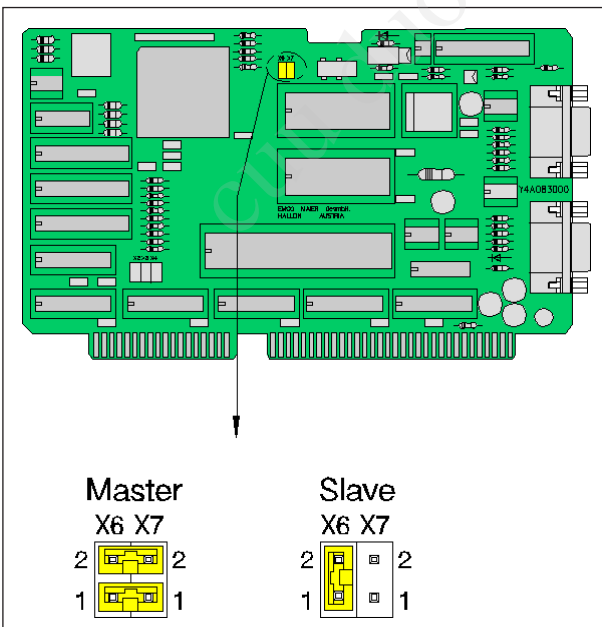

PCCOM setting Master - Slave

Sequence:

Danger:



Mount and dismount the interface card only while the PC is disconnected to the net. Pull power cable!

- Remove the interface board from the PC.
- Put the jumpers X2 - X4 in the required position (positions 1 - 8 see table on previous page).
Pins not connected: L
Pins connected: H
- Mount the interface board in the PC.
- Connect the PC to line and switch on.
- Retry installation of the software.
When the alarm occurs again, try the next jumper position for installation.

PCCOM Master-Slave Setting

Several PCCOM boards can be installed in the PC, e.g. to control more than four axes on a machine.

In this case one of the boards must be set as Master, all other boards must be set as Slaves.

When only one board is installed it also must be set as master.

At delivery all cards are set as Master.

Setting occurs with the jumpers X6 and X7.

Danger:

Mounting and/or dismounting the network card may only be carried out when the computer is disconnected from the mains supply (unplug power plug).

Note:

During a machine installation one network-card is reserved exclusively for the control of the machine.

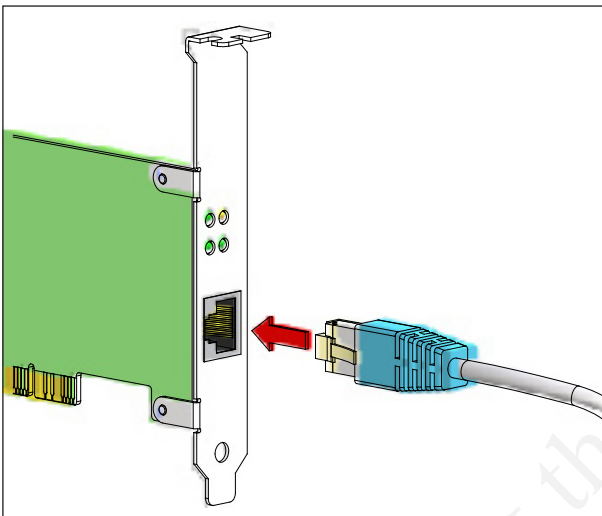

Connection of the machine to the PC

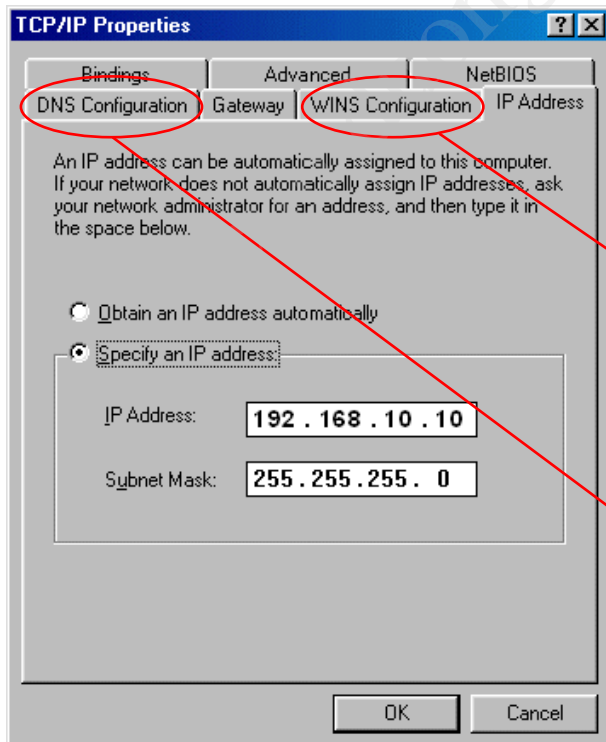

Properties of TCP/IP

Network card (ACC)

for:

Concept Turn 55
Concept Mill 55
Concept Turn 105
Concept Mill 105

Network card type: TCP/IP compatible network card

Setting the network card for the local connection to the machine:

IP- address: 192.168.10.10
Subnetmask 255.255.255.0

In case of problems observe the instructions of your operating system (Windows help).

Example for Windows 98:

Furthermore, in the registers "DNS configuration" and "WINS configuration" these should be activated.

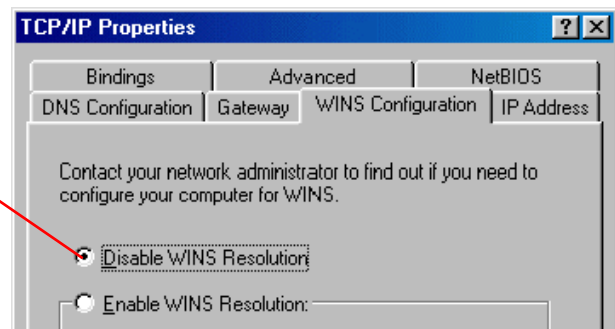

Disable WINS configuration

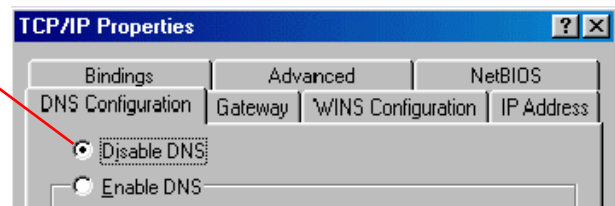

Disable DNS configuration

Example for Windows XP:

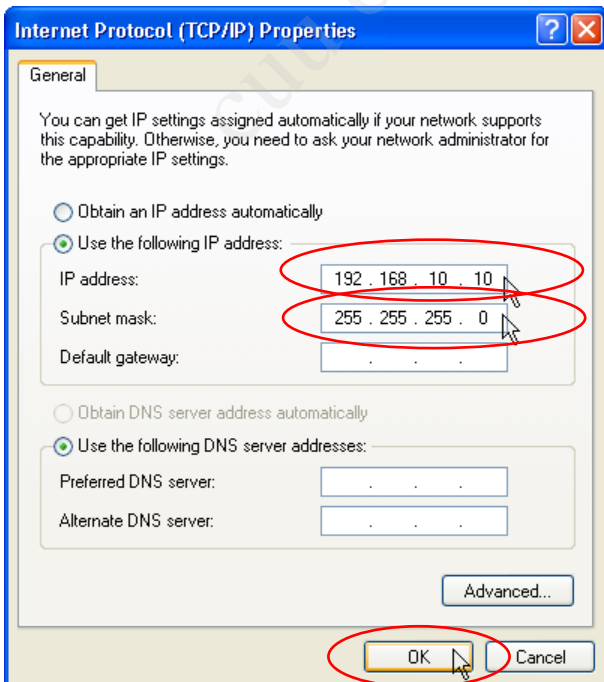
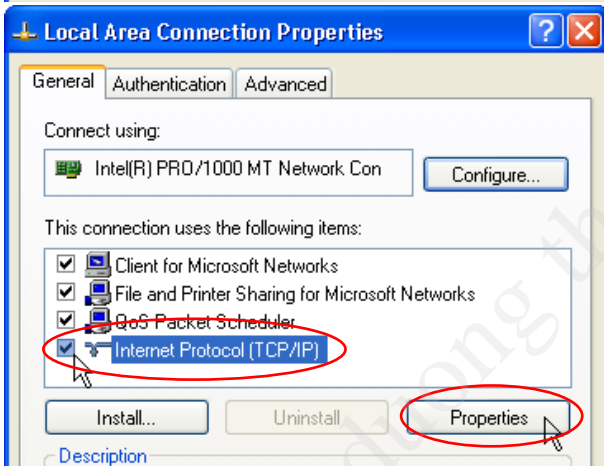
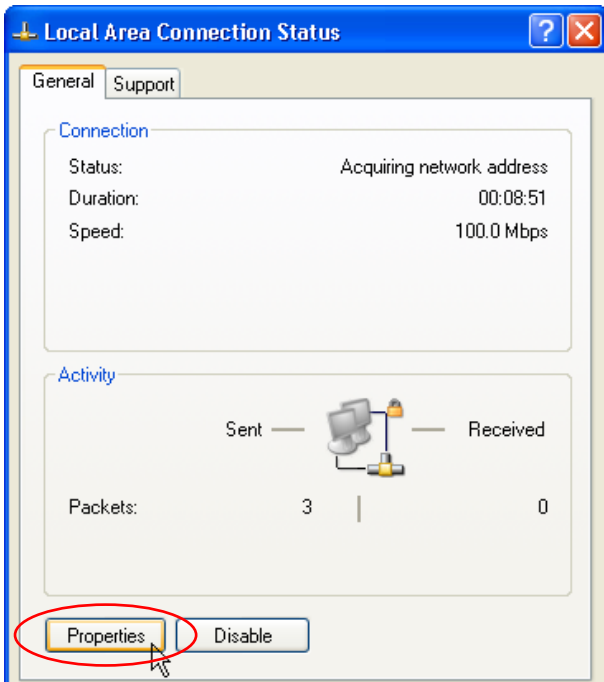

Example for Windows Vista:

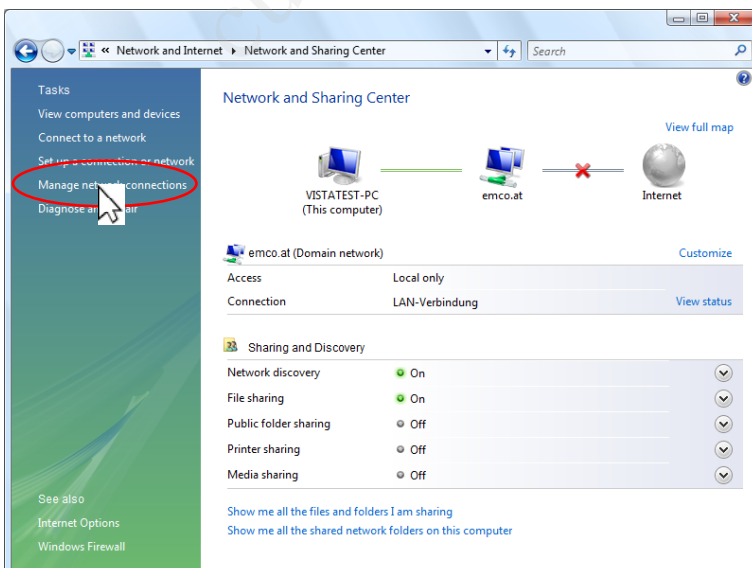
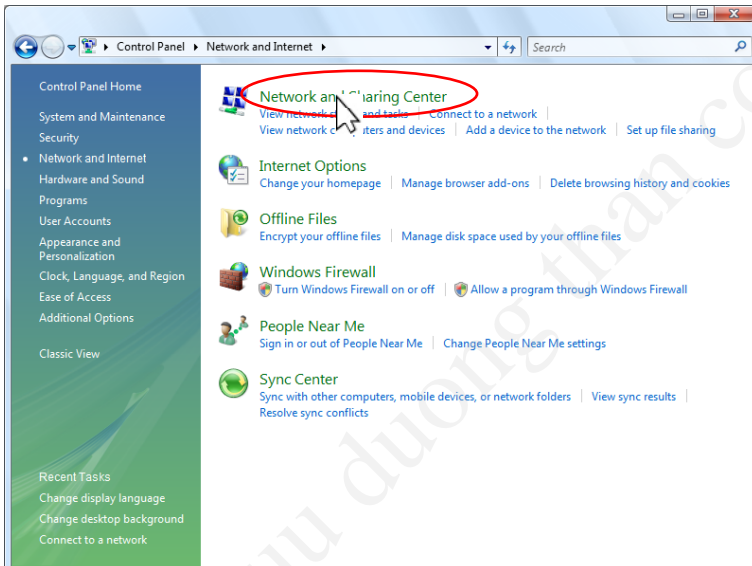
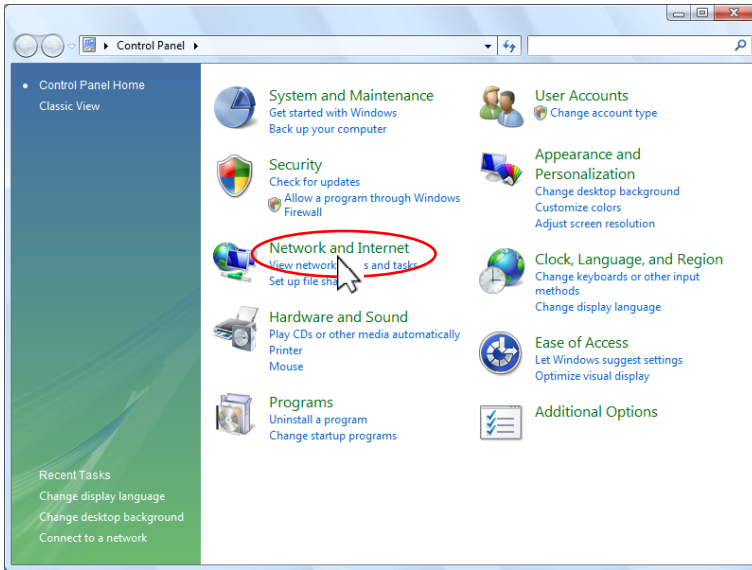

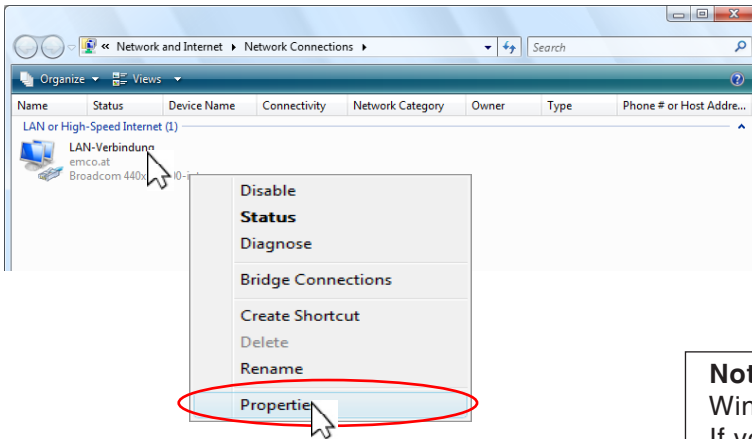

Note:
Windows needs your permission to continue.
If you started this action, continue.

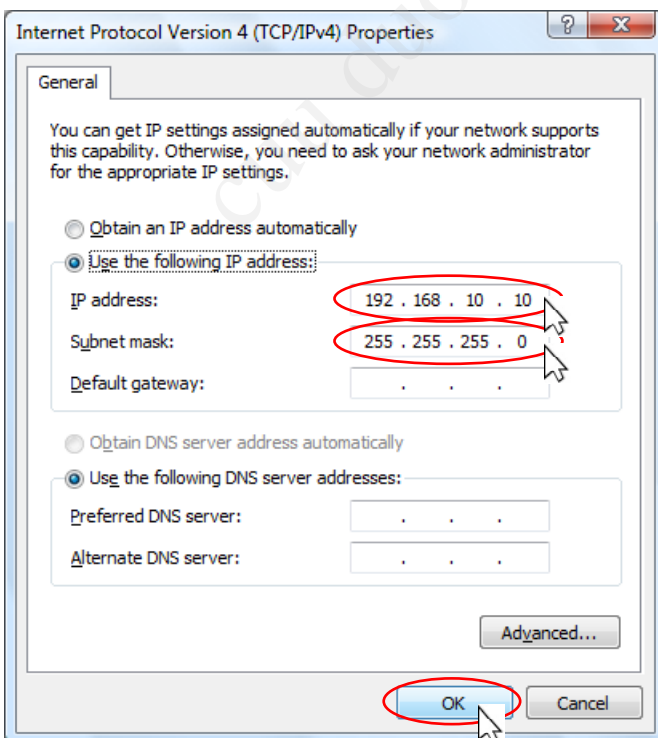
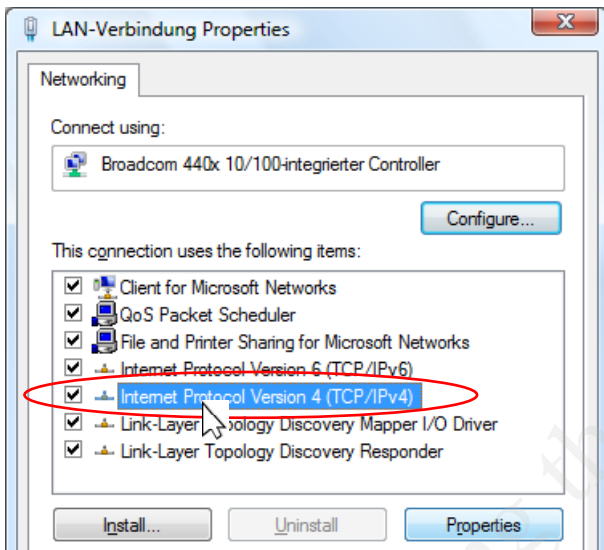

Note:

With ACC the machine must be switched on first.

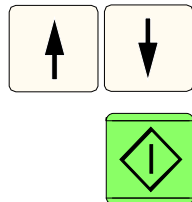

Starting WinNC

If you have selected "YES" for the last query in the machine version installation (entry in the file AUTOEXEC), WinNC starts automatically after switching on the PC.

Otherwise act as following:

- Switch on the PC and start Windows 95 (resp. automatic start).
- Click on the start symbol in the bottom line.
- Select Programs, EMCO and click on WinNC.
- The screen shows the start picture. In the start picture the version number of WinNC and the licensee are displayed.
- If you have installed one control type only, it will start immediately.
- If you have installed several control types, the screen shows the selection menu.
- Select the desired control type (cursor keys or mouse) and press ENTER to start it.
- If you use the control keyboard, select the desired control type with the JOG keys and start it with NC-Start.

Closing WinNC

Switch off auxiliary drives.

By similar pressing the keys "Alt" and "F4" (PC keyboard) or the keys „SKIP“ and „RESET“ (accessory control keyboard) the control system will be ceased and you are back in the selection menu for the control types.

Press Alt+F4 again to close WinNC.

With the mouse you can close WinNC by clicking on the symbol in the headline.

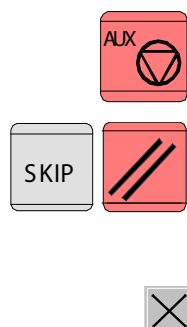

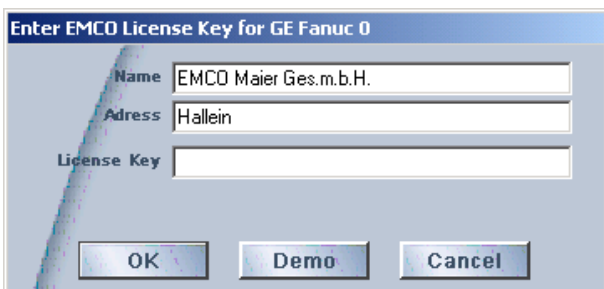

Input window license key enquiry

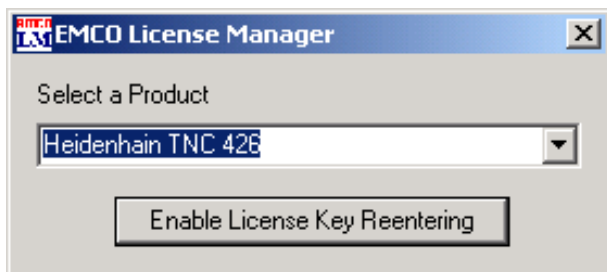

EMCO License Manager

Licence input

After having been successfully installed, an input window appears during initial operation of an EMCO software product and asks for name, address and licence key. This input window appears for every software product installed. In case a demo licence is desired (see page Z1), please select "DEMO".

The input window reappears only 5 days before the expiry of the demo licence. A subsequent input of a licence key is also possible via the licence manager (see licence manager below).

License manager

For the release of additional function groups of existing EMCO software products it is necessary to enter a new licence key (exception: demo licence).

The **EMCO License Manager** (see picture on the left) enables the input of further new license keys. For this purpose select the new product in the selection window and confirm the input.

The next time you start your control software an input window appears and asks you to enter name, address and licence key (see picture on the top left).

Please note that the licence key is asked for each software product individually. The picture on the left shows e.g. the input prompt for the licence key for the software product "Heidenhain TNC 426".

cuu duong than cong . com